

Revision 0

September 2010

Platinum®

by TUNTURI

4 in 1 Strength Station

Owner's Manual

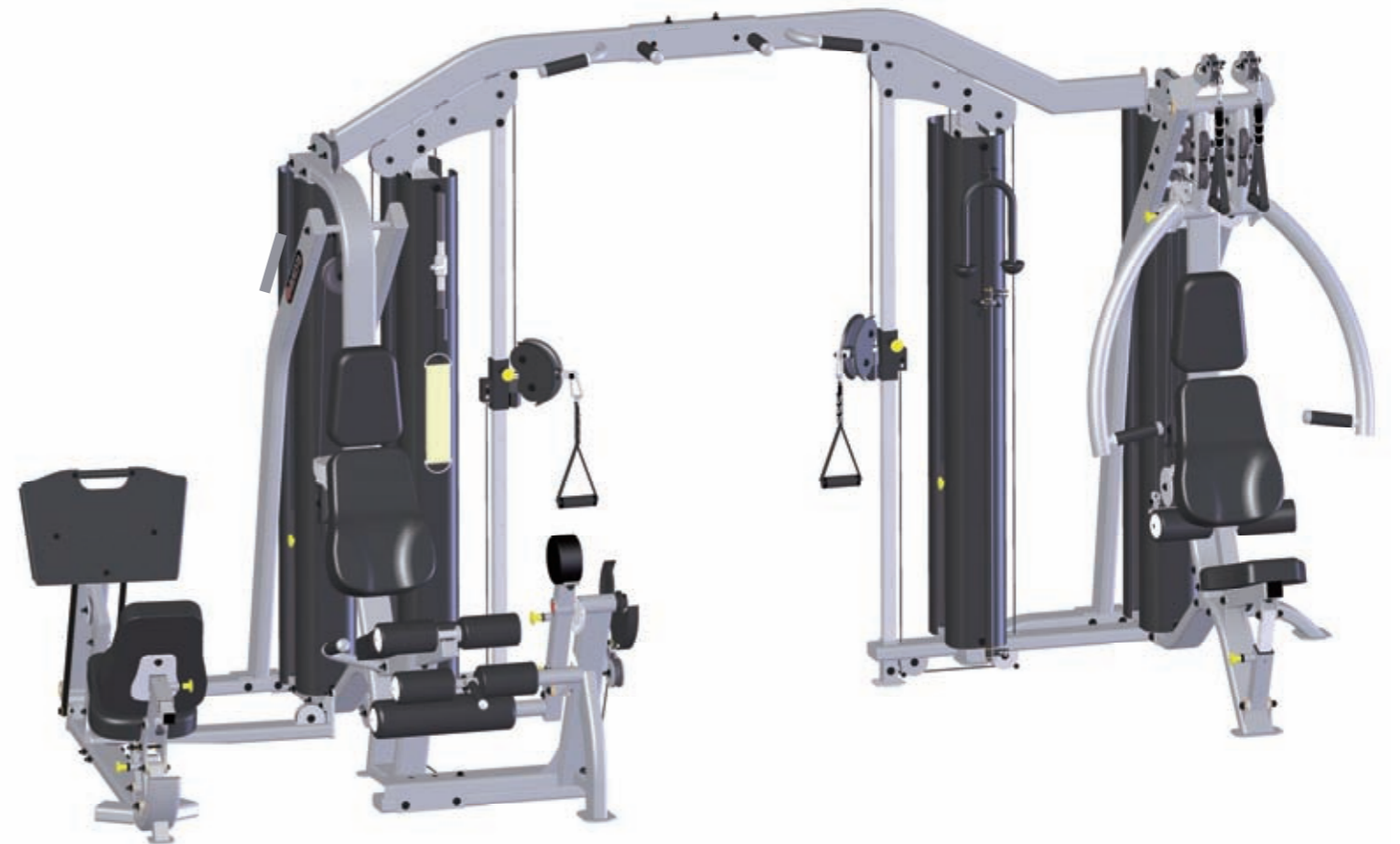

Record Serial Number Here

Date of Purchase

Platinum by Tunturi
www.tunturi.com

Instructions

Congratulations on the purchase of your new 4 in 1 Strength Station. This gym will provide you with a lifetime of enjoyment to meet your strength training needs. Platinum by Tunturi strives to build the best quality multi-station gyms and to package these gyms in such a way to avoid any damage during shipping.

In order to get started with your assembly you should first familiarize yourself with this manual. It is recommended that you read through each step thoroughly before you begin. Begin by opening your boxes and separating all of your parts. Verify that all parts are accounted for and have no damage. When all parts are accounted for, you may begin your assembly. Some items may have been pre-assembled for your convenience. Please note that hardware quantities shown reflect total quantities for your gym and may not reflect actual quantities in each bag. Assemble your gym on a solid level surface. This will ensure the best possible performance, function, and safety for the gym and your workout.

Assemble your gym according to the step by step instructions found in this manual. Failure to do so will void your warranty and may result in personal injury. After assembly, you should check each station to ensure correct operation. If a problem arises, recheck your assembly with these instructions to verify correct assembly. If you are unable to correct a problem or have questions with your assembly please contact your authorized Tunturi dealer.

Warning

Platinum by Tunturi has built this gym to give you a safe, effective and enjoyable workout. However, there is a risk assumed by individuals who use this type of equipment. It is very important that all warnings and instructions are read and followed before beginning any exercise program.

It is also very important to read and follow the preventative maintenance schedule described in this manual. If any of the warning labels or stickers are worn, faded, torn, scratched or missing they should be replaced immediately.

WARNING: There is a risk assumed by individuals who use this type of equipment. To minimize risk always follow these rules.

- 1) It is essential that you consult with your physician before beginning any exercise program.
- 2) Inspect equipment before each use for loose, worn, or frayed parts (including cables, nuts and bolts). Replace parts at first signs of wear (use only genuine Tunturi replacement parts). Use of equipment that is damaged, worn, frayed or not completely assembled on a solid, level surface may result in injury.
- 3) Make sure all adjustment pins are fully engaged before using equipment.
- 4) Keep all parts of the body and clothing outside the path of any moving parts of the gym. Be alert to the possibility of injury. Do not be careless.
- 5) Minors and children should not be allowed to play on or around this gym.
- 6) If you have any questions on proper use or maintenance of this gym, do not hesitate to call your local PLATINUM BY TUNTURI distributor or TUNTURI www.tunturi.com

Table of Contents

	<u>Page</u>		<u>Page</u>
Instructions	2	Cable Tension and Adjustments	16
Parts Listing	3	Weight Stack Decals and Serial Number	17
Hardware Comparison	4-7	Final Assembly and Troubleshooting	18
Pre-Assembly Instructions	8	Maintenance	19
Main Frame Assembly	9-12	Floor plan Layout	20-21
Cable Routing	13-14	Contact	22
Accessories Holders and Shrouds	15		

Contact

Benelux

Accell Fitness Benelux
Koningsbeltweg 51
1329 AE ALMERE
The Netherlands
Tel: +31 36 5460050
Fax: + 31 36 5460055

Scandinavia

Accell Fitness Scandinavia
Varusmestarintie 26
20361 TURKU
Finland
Tel: +358 10 2733 200
Fax: +358 2513 313

Germany

Accell Fitness Deutschland
P/a Koningsbeltweg 51
1329 AE ALMERE
The Netherlands
Tel: +31 36 5460050
Fax: + 31 36 5460055

North America

Accell Fitness North America Inc.
130 Hayward Ave, Suite 2
N2C 2E4
Kitchener, ON Canada
Tel. 1-888-388-6887
Fax: 1-519-576-2521

www.accellfitness.com

www.tunturi.com

Frame Components

ITEM NO.	DESCRIPTION	QTY
1	Right Side Height Adjustment	1
2	Swivel Pulley Holder	2
3	Short Base Frame	1
4	Selector Tube	2
5	Long Base Frame	1
6	Left Side Height Adjustment	1
7	Pulley Holder/Support Plate	4
8	Upper Support Brace (Right Side)	1
9	Extended Upper Support Brace (Left Side)	1
10	Front Angle Bracket	1
11	Rear Angle Bracket	1
12	Guide Rod Holder	2
13	Top Weight Plate	2
14	Guide Rod	4
15	Weight Plate	38
16	Rubber Donut	4
17	Free Floater (Male)	2
18	Short Bar/Ankle Strap Holder	1
19	Front Shroud	2
20	Rear Shroud	2
21	Rope/Long Bar Holder	1

Hardware

ITEM NO.	DESCRIPTION	QTY
25	Threaded Collar	2
26	HCS 3/8"-16x 5"	4
27	HCS 3/8"-16x 2-1/2"	16
28	HCS 3/8"-16x 5-1/4"	4
29	FHSCS 3/8"-16x 3"	2
30	FHSCS 3/8"-16x 5-1/4"	2
31	HCS 3/8"-16x 3"	4
32	4-1/2" Pulley	8
33	3-1/2" Pulley	8
34	3/8" Pulley Spacers	12
35	HCS 3/8"-16x 2"	10
36	HCS 3/8"-16x 2-1/4"	6
37	HCS 3/8"-16x 1-3/4"	2
38	HCS 3/8"-16x 1/2"	8
39	3/8" Lock Washer	10
40	3/8" Flat Washer	78
41	3/8" Nylock	48
42	Weight Stack Decals	2
43	Guide Rod Lubricant	2

Accessories

ITEM NO.	DESCRIPTION	QTY
22	Weight Stack Pull Pin	2
23	Strap Handle	2
44	Low Row Bar	1
45	Straight Bar	1
46	Triceps Rope	1
47	Ankle Strap	1
48	Foot Strap	1

Cables

ITEM NO.	DESCRIPTION	QTY
24	Functional Trainer Cable	2

Tools Required

- 1/2" Wrench
- 9/16" Wrench
- 9/16" Ratchet
- Allen Wrench Set
- Tape Measure
- Snap Ring Pliers

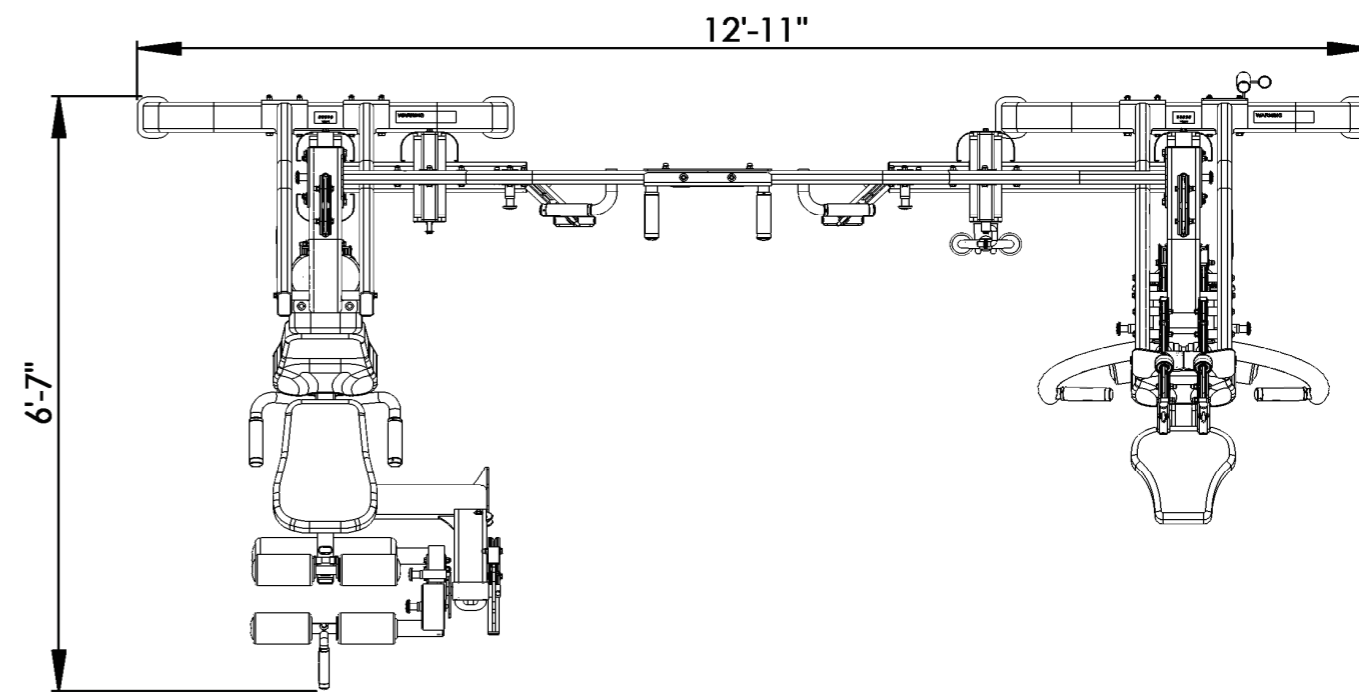
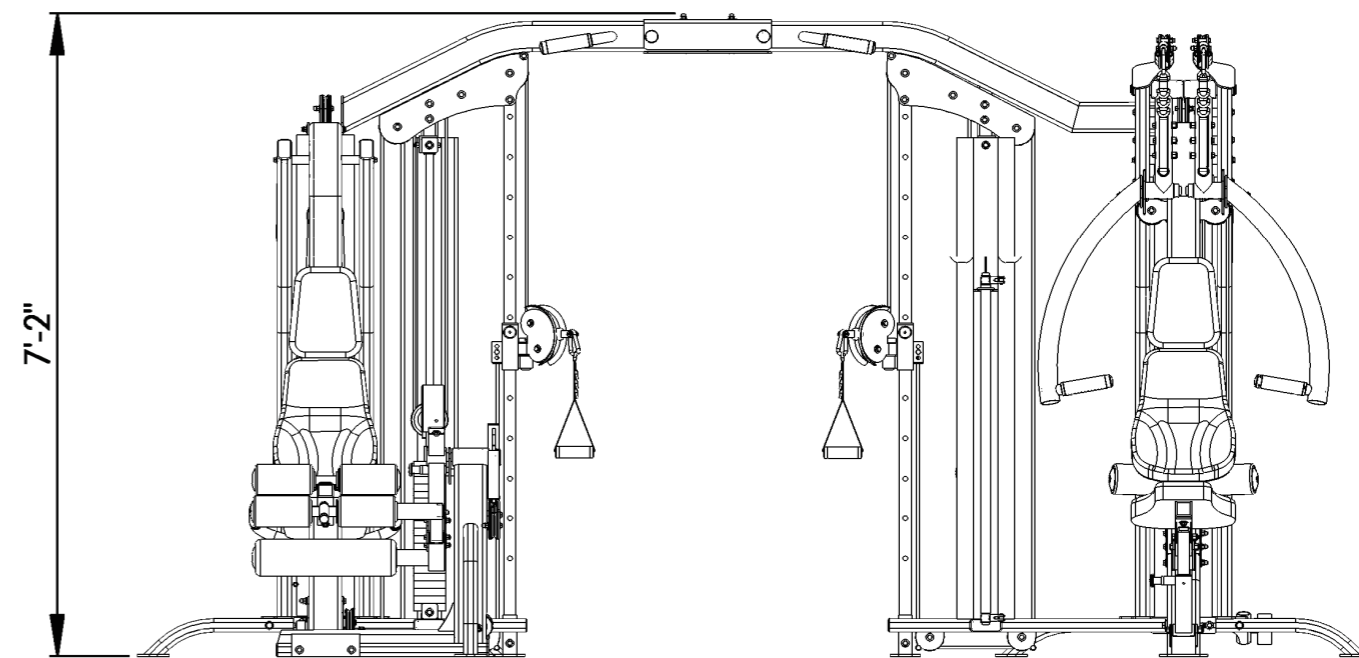
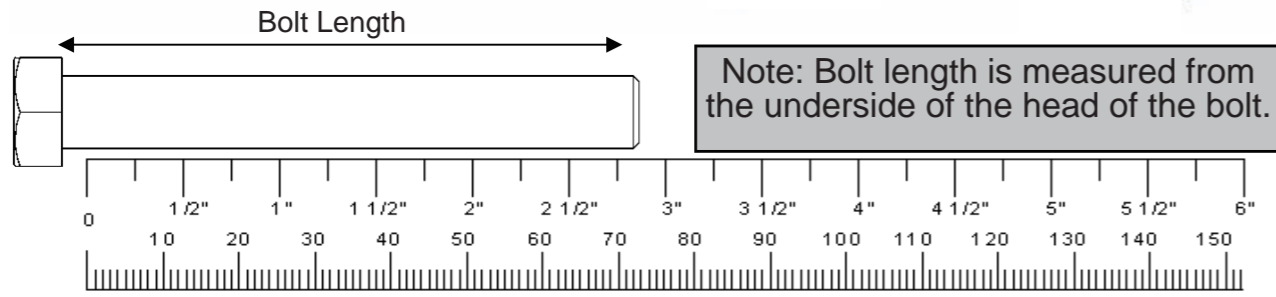
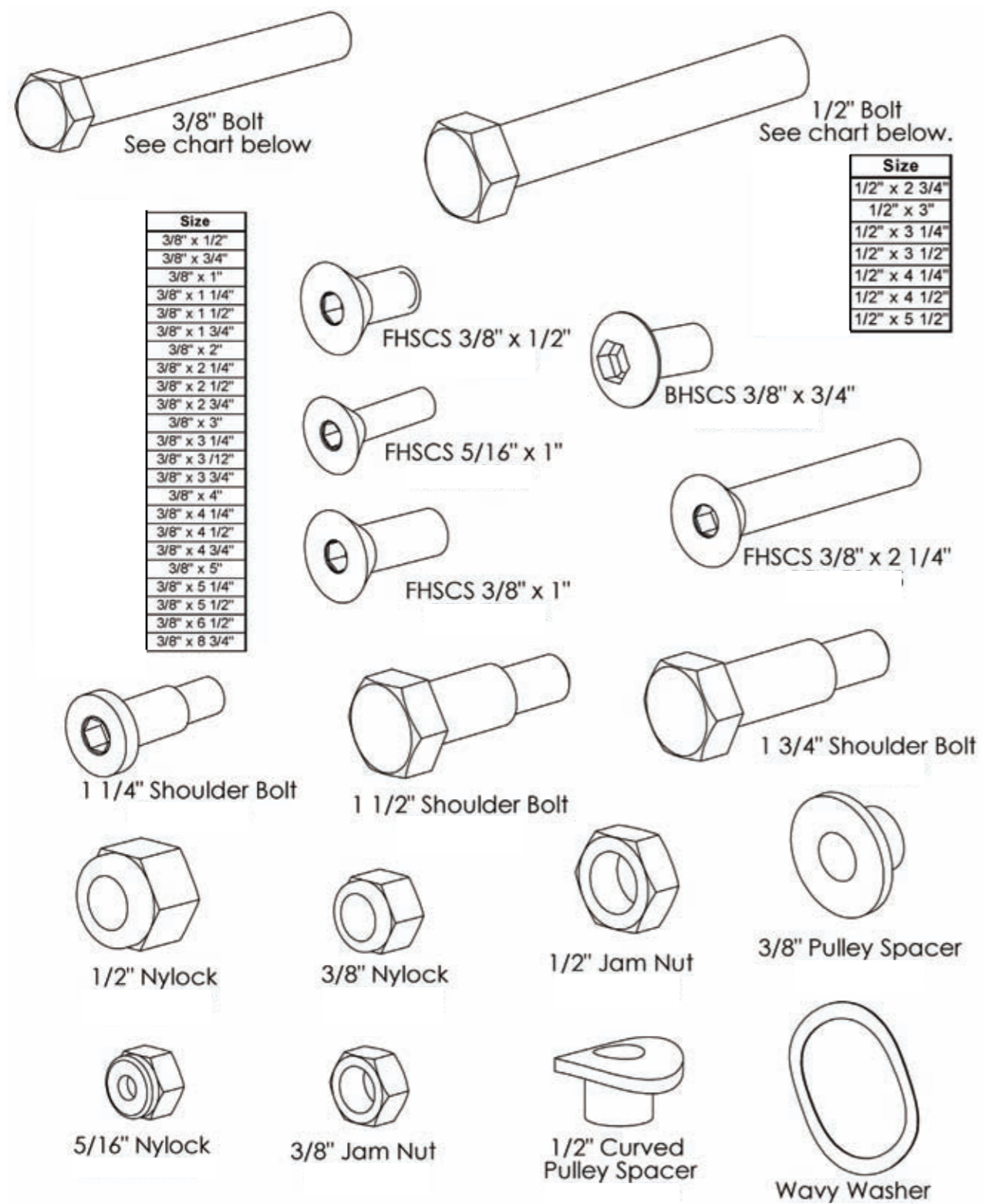

Layout Diagram without Leg Press

The Platinum without Leg Press has a layout dimension of 12'-11" (width) x 6'-7" (length) x 7'-2" (height). There should be a minimum of 18", preferably 24", of working space around the entire unit.

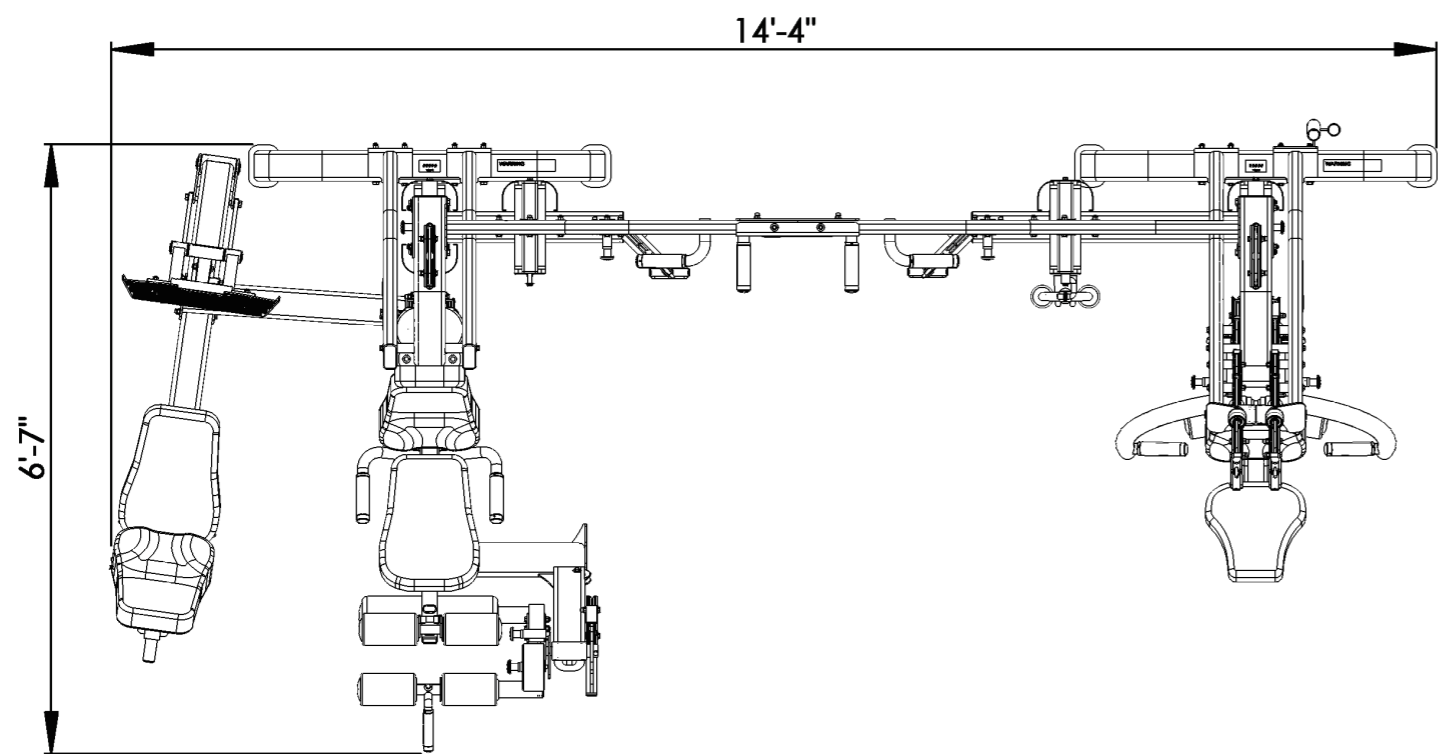
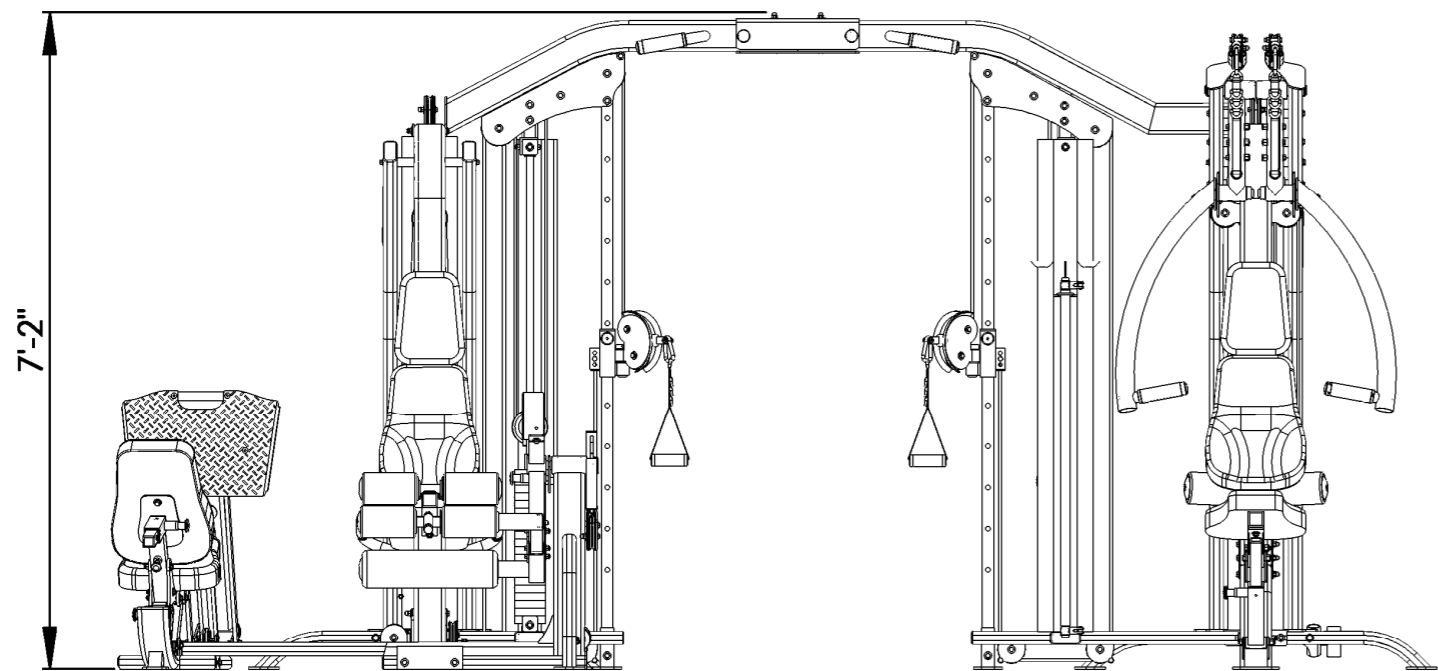

Layout Diagram with Leg Press

The Platinum with Leg Press has a layout dimension of 14'-4" (width) x 6'-7" (length) x 7'-2" (height). There should be a minimum of 18", preferably 24", of working space around the entire unit.

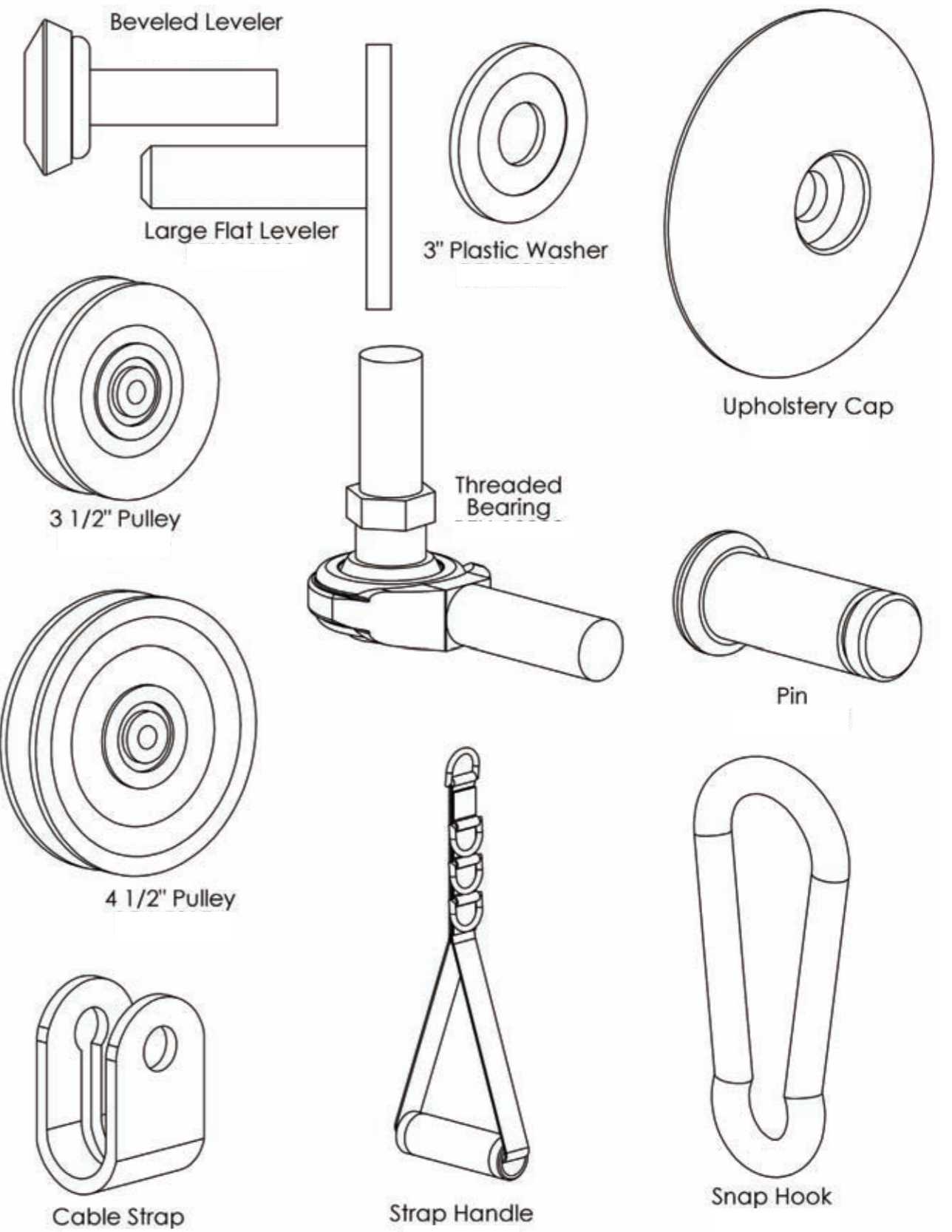

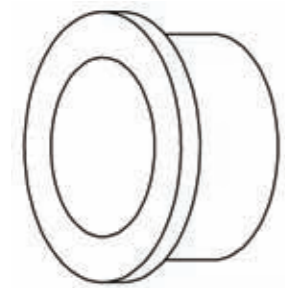

1" Bronze Bushing

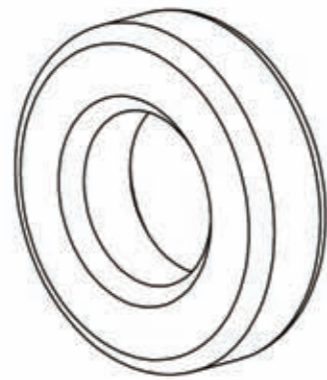

1" ID Bearing



1/2" Lock Washer (Black)

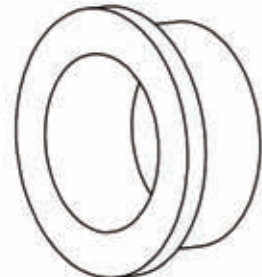

1" Bronze Bushing x 1/2 L

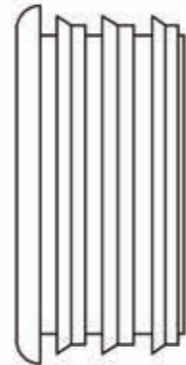

2" Round Plastic Cap

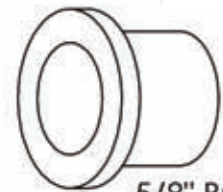

5/8" Bronze Bushing



2" Internal Snap Ring



1" Inner Plastic Cap

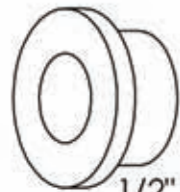

1/2" Bronze Bushing



1" Snap Ring



Snap Ring



Cable Pivot Bushing



Short 1/2" Bushing



1/2" Snap Ring



1/4" Sleeve

Preventive Maintenance

Platinum by Tunturi strives to give you the very best in quality, performance and safety through carefully engineered designs and excellent workmanship. In order to maintain this high level of quality the preventative maintenance schedule below should be followed.

Clean upholstery, grips, and roller pads with mild soap and water generally after every use. The guide rods, chrome slides and frame should be cleaned with a cotton cloth. Upon cleaning the guide rods, a thin layer of Silicone or Teflon gel should be applied to each rod to ensure a glass smooth performance.

An overall inspection should be done before each workout. If the warning and safety decals are worn or have been removed they should be replaced immediately. The cables and cable systems should be inspected for signs of wear and proper tension. In order to check cables properly you should carefully run the cable through your fingertips, checking for signs of wear, cracks, burs and thinning spots. Replace any part at first signs of wear. Cables should be adjusted for proper tension. See assembly instructions for this detail. All hardware, stops, and adjustments should be checked and tightened as required.

The guide rods on your machine should be cleaned and lubricated regularly. This will ensure a glass smooth performance from your weight stack. A thin layer of either Silicone or Teflon gel should be applied to each rod. Each pillow block bearing and flange bearing has a grease fittings that must be lubricated regularly. Use general purpose bearing grease and follow the schedule below.

Although cables should be inspected daily, it is important that ALL cables be replaced as directed in the schedule below. Please note that at any first sign of wear the cable should be replaced immediately.

If there are any questions concerning maintenance, please contact your local Tunturi dealer or contact Platinum by Tunturi directly at:

www.tunturi.com

	Daily	Weekly	Monthly	Quarterly	Years
Clean					
Upholstery		X			
Hand Grips		X			
Roller Pads		X			
Guide Rods			X		
Chrome Slides			X		
Frame			X		
Inspect					
Overall	X				
Safety Decals	X				
Cables	X				
Cable Tension			X		
Pulleys	X				
Hardware	X				
Stops	X				
Upholstery	X				
Hand Grips			X		
Frame			X		
Bushings		X			
Bearings		X			
Lubricate					
Guide Rods			X		
Bearings					1
Replace					
Cables					3

Final Assembly and Troubleshooting

IMPORTANT - Check These Components Before Using Gym:

- **Wrench Tighten** the set screws on all Threaded Collars using an allen wrench, so that the set screws tighten against the shaft. Refer to Step 1.

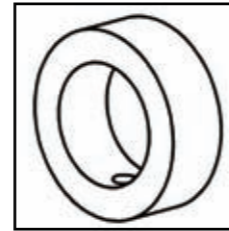

Threaded Collar

- Each Free Floater **must be threaded at least 1/2"** into the Top Plate of the weight stack. Each must also be secured with a 1/2" Jam Nut to ensure a safe and proper connection.

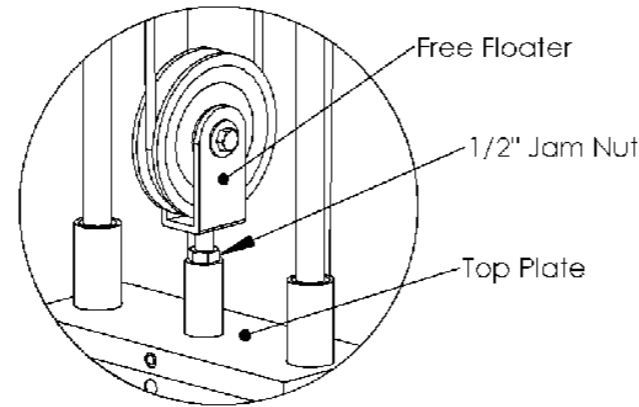

Make Sure Cable is not pinched in between the tube and the pulley support plate.

- Verify that all cables lie in between the guide bolts, tubes and the pulleys. Routing the cables over the guide bolts causes premature cable wear and will void your warranty.

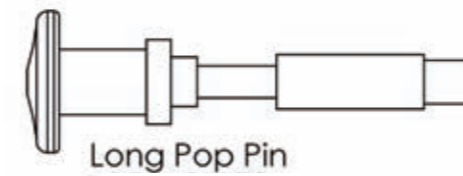
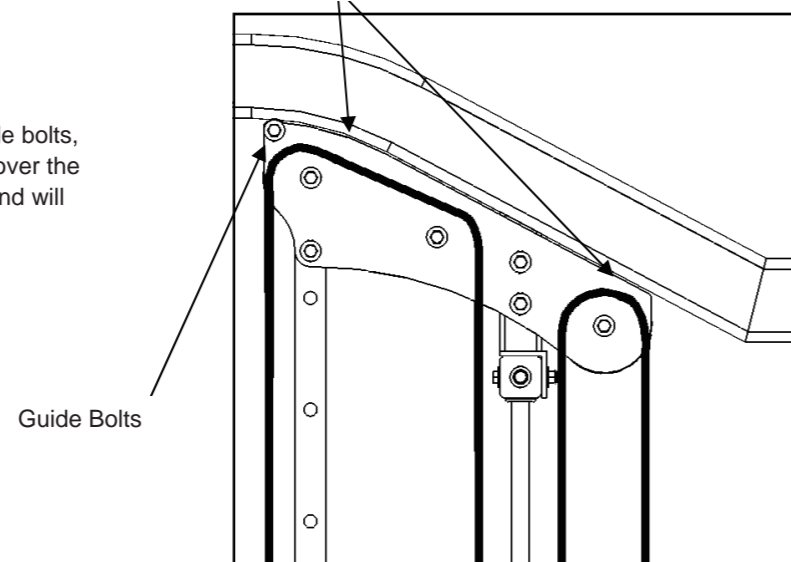

Long Pop Pin

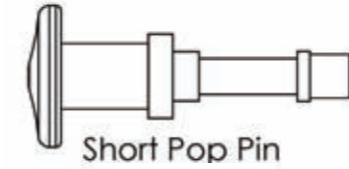

Short Pop Pin

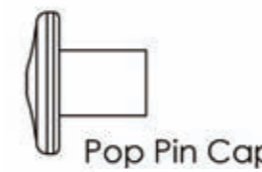

Pop Pin Cap

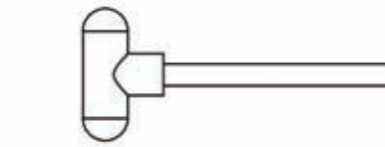

Magnetic Weight Stack Pin

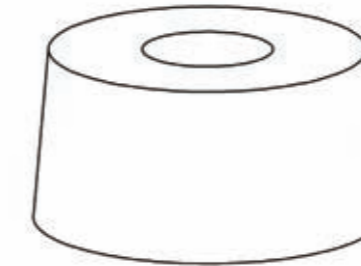

Rubber Donut

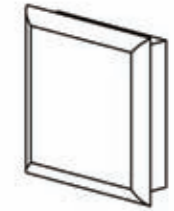

Plastic Cap

Size
2" x 2"
2" x 3"
1 1/2" x 2"
1 3/4" x 1 3/4"
1 1/2" x 1 1/2"



3/8" Curved Washer



3/8" Flat Washer



1/2" Flat Washer

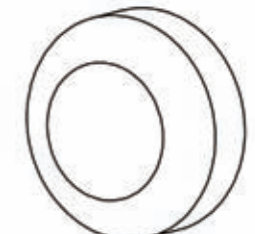

Screw Cap Cover

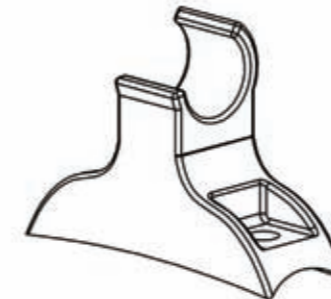

Mounting Bracket



3/8" Lock Washer

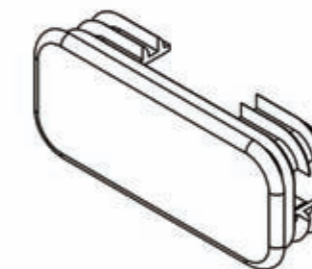

1 3/4" x 4" Rectangular Cap



6" Rubber Grips (Yellow)

Items not shown.

Silver Metallic Paint
Large Logo
Small Logo
Foam Grip
Silicon Gel Pack

Pre-Assembling Instructions



NOTE: It is important to position the Upper Body and the Lower Body Stations accordingly. Make sure they are approximately 5 foot 1 inch apart by measuring from the inside of the rear base on each machine. Also Make sure the rear base on each machine are in line with each other across the back. This is important for connecting the two machines via the Cable Cross Over as seen in step 3. This will help to insure all of the components on the 4 in 1 Strength Station line up smoothly and will help to make the installation process effortless.

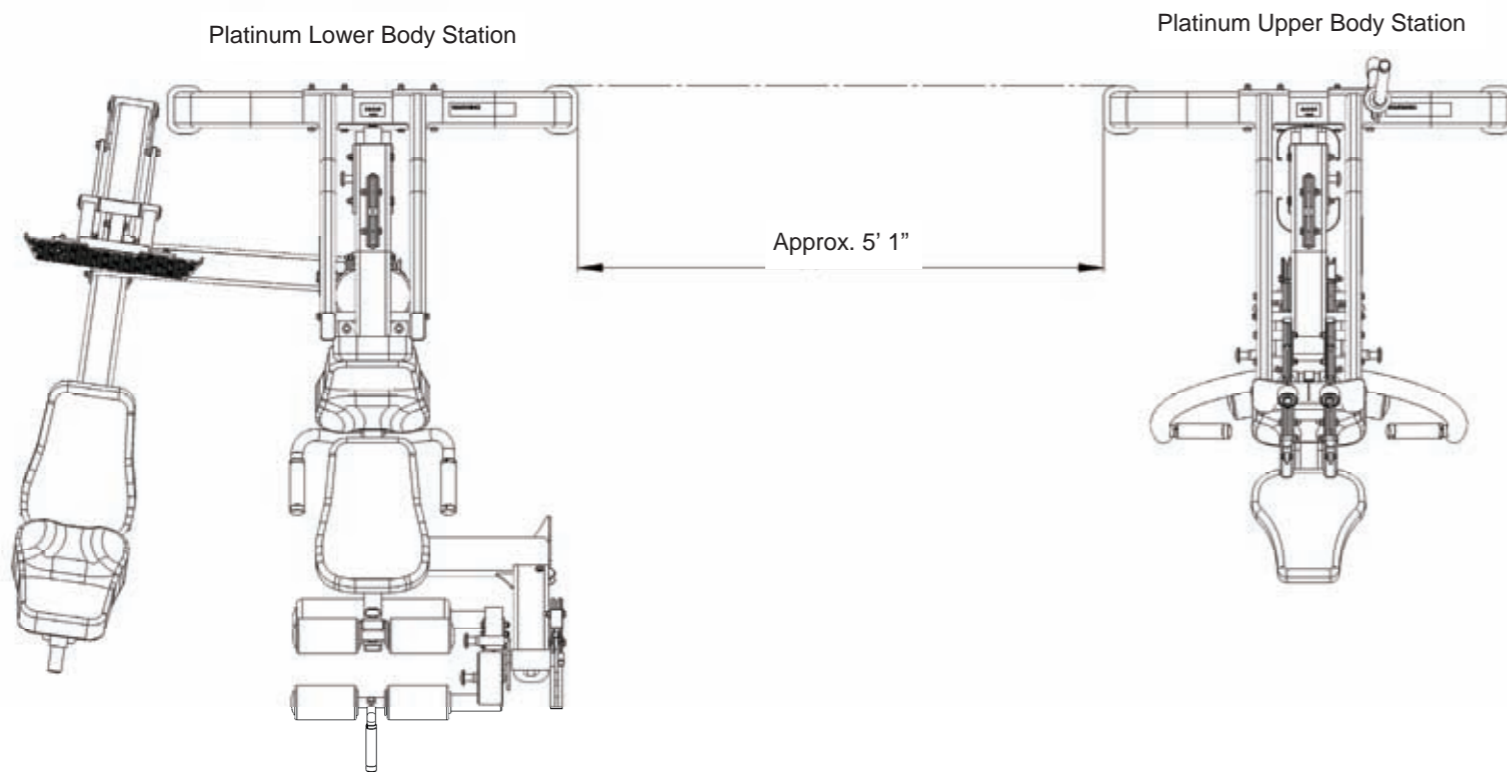

Final Assembly and Troubleshooting

Weight Stack Decals:

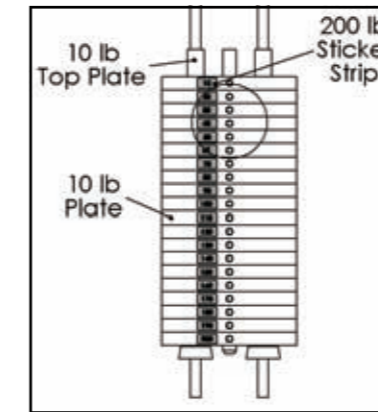

200lb Stack (Standard)

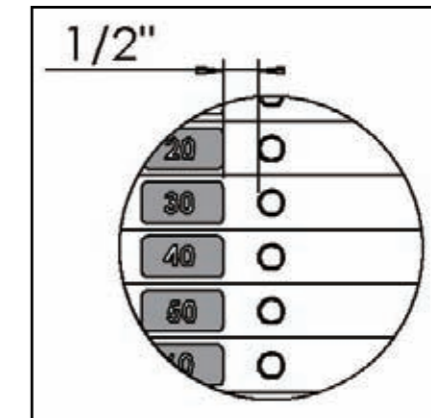

Guide Rod Lubrication:

- Clean guide rods with a lint-free cloth and apply a thin layer of silicon lubricant to each guide rod. This will ensure a glass smooth performance from your weight stack.

Cable Adjustments

- **Adjust** cables to proper tension from any of the locations shown below.

Note: All cables with threaded adjustable ends must have at least 1/2" of the threads threaded in to its counterpart. It is very important that the 1/2" Jam Nut be wrench tightened to the counterpart to ensure that the threaded adjustable end of the cable does not back out of its counterpart.

- **Note:** If the top plate raises off of the second plate in the weight stack, then the cable tension is too tight. You will need to take some of the tension out to lower the Top plate flush with the second plate.

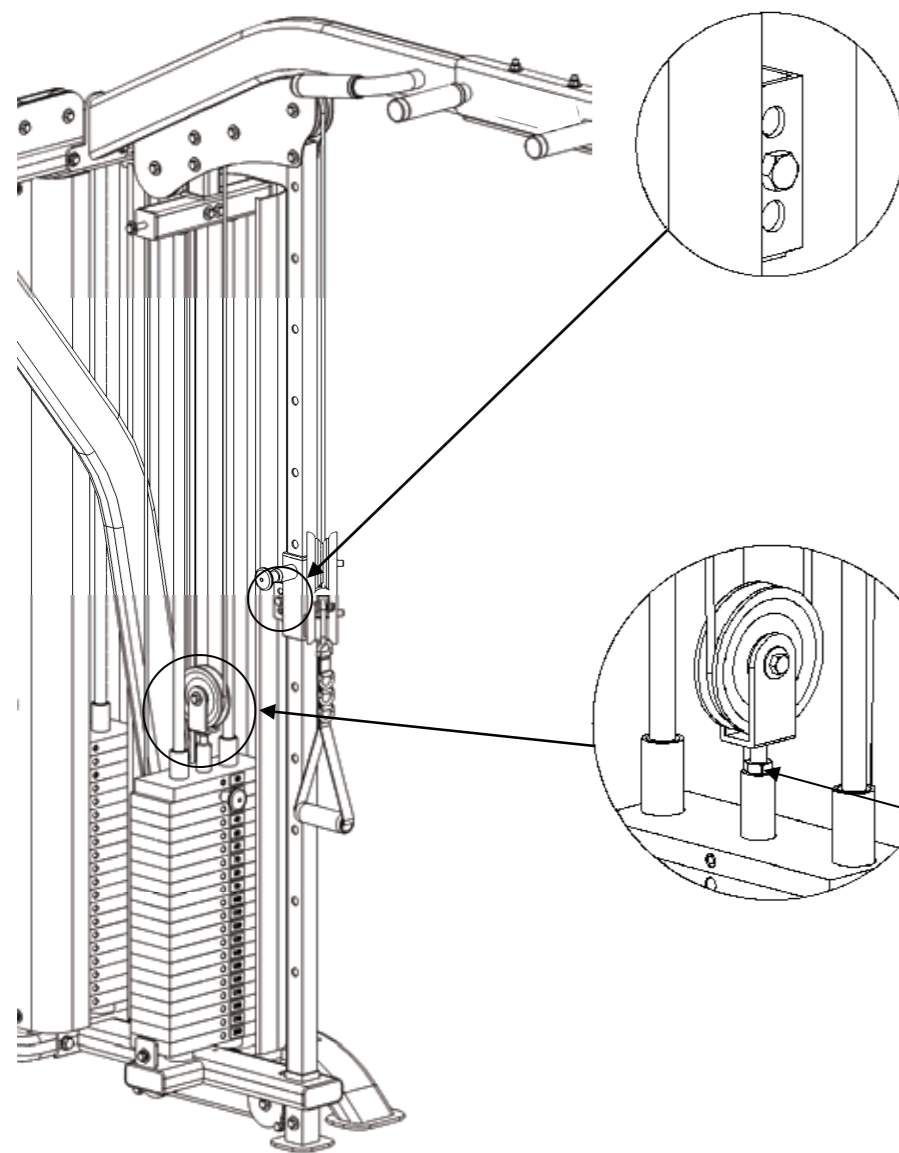

This bolt can be positioned in any one of the three optional holes to account for any slack in the cable. Refer to Step 5.

Fine adjustments to cable tension can be made here. At least 1/2" of the threads should be threaded in to the top weight plate. It is very important to tighten the jam nut after adjustments.



PLEASE FOLLOW ALL DIRECTIONS VERY CAREFULLY FOR PROPER INSTALLATION.

Step 1:



Note: For a more consistent appearance, position all bolts in the direction shown in each figure.

- All Flat Washers and Nylocks are 3/8"

Do Not Tighten Hardware Until Step 3

Step 1a:

Repeat step 1 for opposite (Left) side

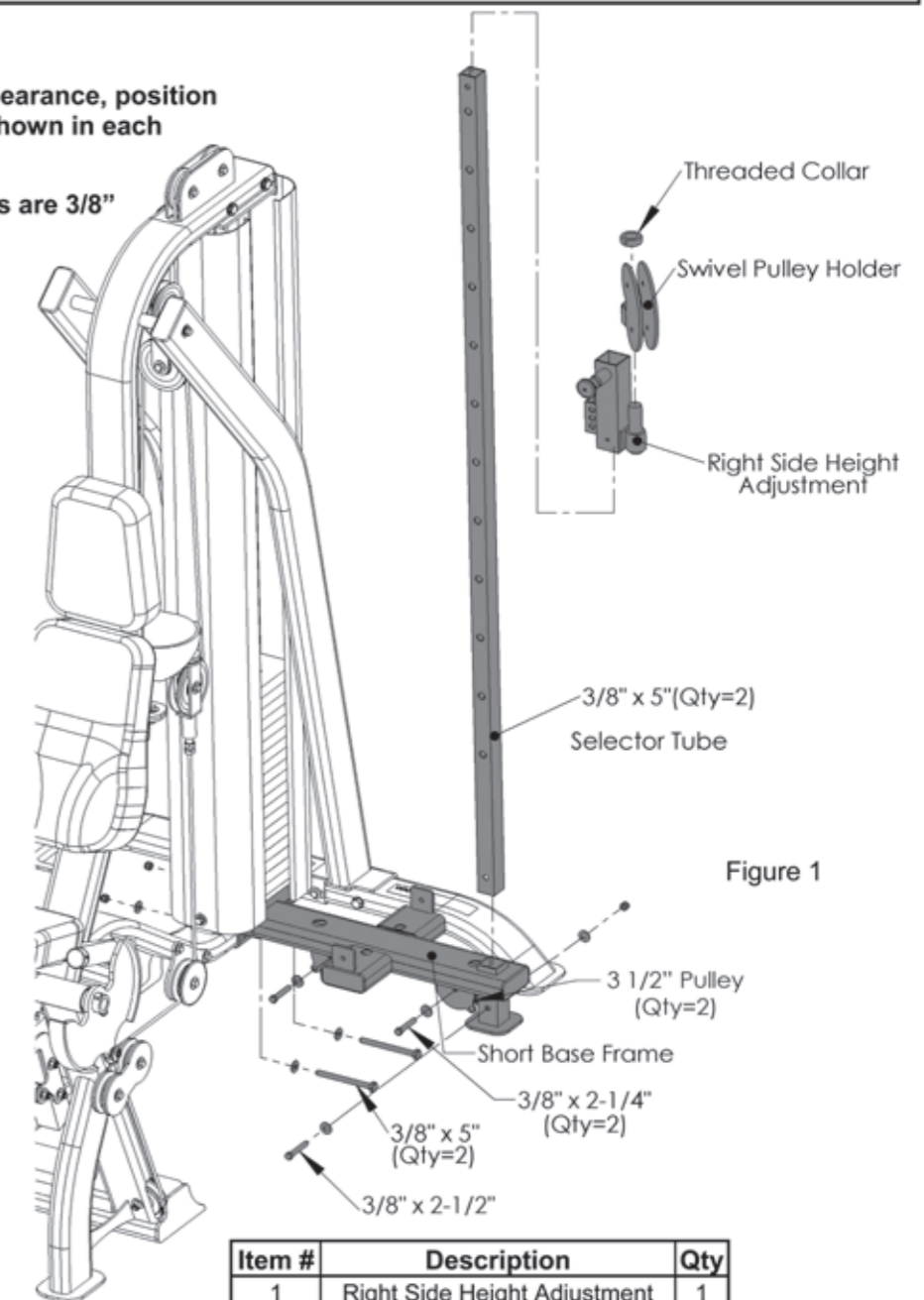
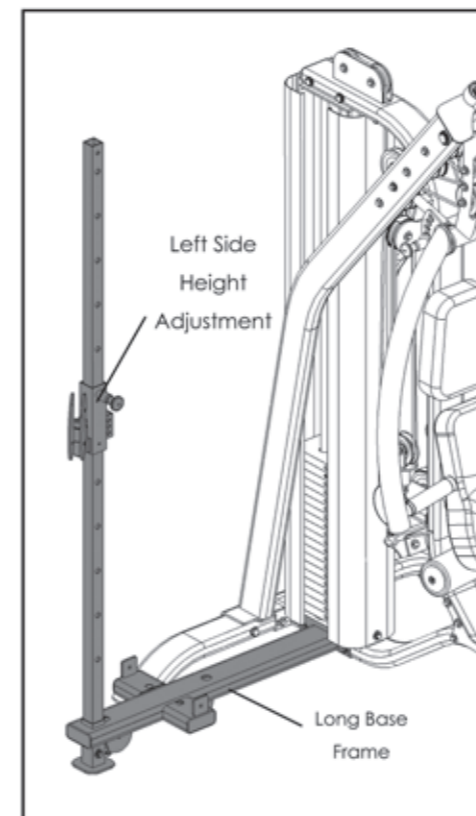

Figure 1

Item #	Description	Qty
1	Right Side Height Adjustment	1
2	Swivel Pulley Holder	1
3	Short Base Frame (Right Side)	1
4	Selector Tube	1
5	Long Base Frame (Left Side)	1
6	Left Side Height Adjustment	1
25	Threaded Collar	1
26	HCS 3/8"-16 x 5"	2
27	HCS 3/8"-16x 2-1/2"	1
33	3 1/2" Pulley	2
36	HCS 3/8"-16 x 2 1/4"	2
40	3/8" Flat Washer	10
41	3/8" Nylock	5

Step 2:

Note: Be sure to remove the 3/8" x 5" bolts from the top of the Lower Body Station and the Upper Body Station and use the 3/8" x 5 1/4" bolts provided with the Functional Trainer.

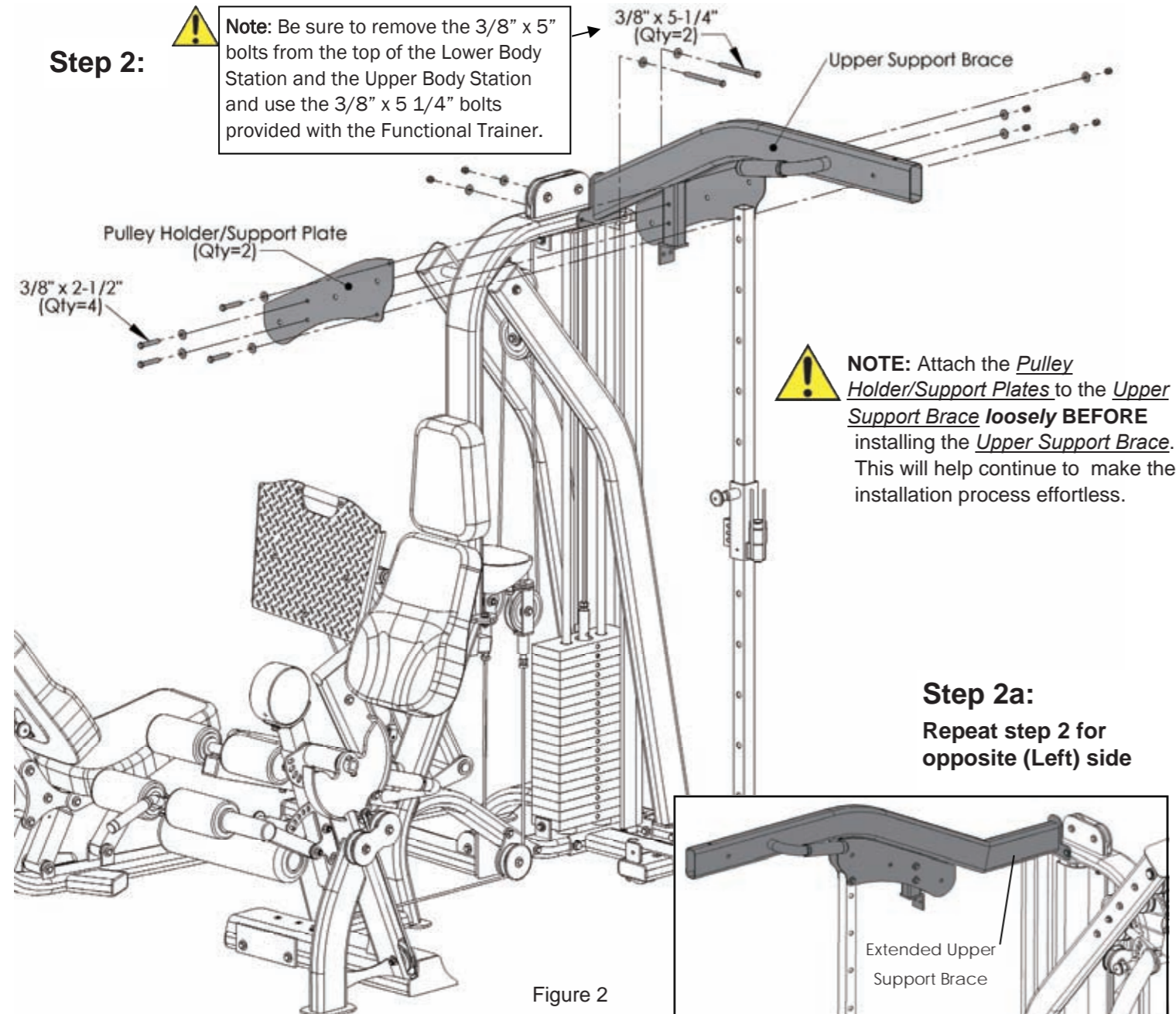

Figure 2

Do Not Tighten Hardware Until Next Step.

Item #	Description	Qty
7	PulleyHolder/Support Plate	2
8	Upper Support Brace (Right)	1
9	Extended Upper Support Brace (Left Side)	1
27	HCS 3/8"-16 x 2 1/2"	4
28	HCS 3/8"-16 x 5 1/4"	2
40	3/8" Flat Washer	12
41	3/8" Nylock	6

All Flat Washers and Nylocks are 3/8" unless otherwise noted.

Step 6:

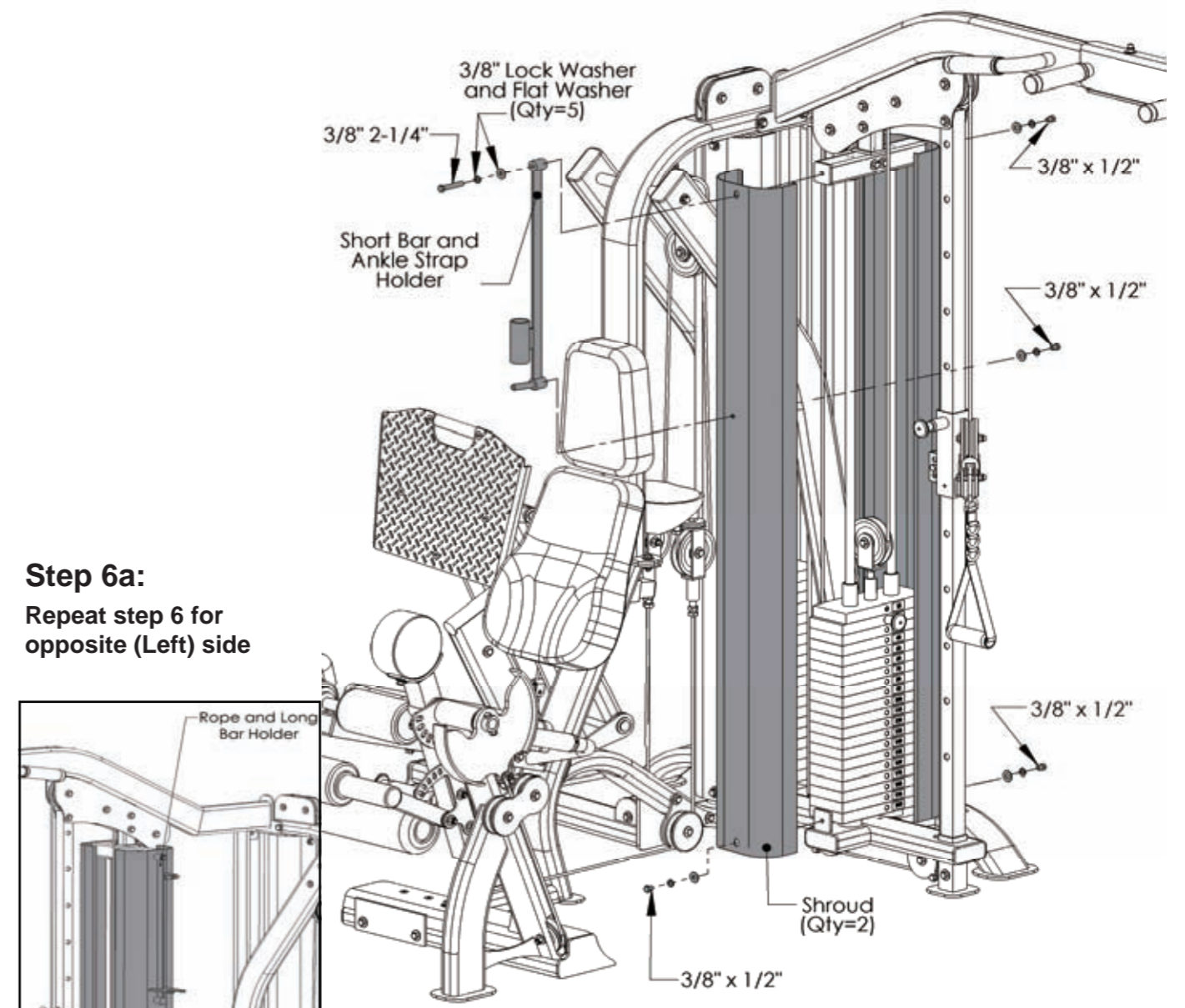
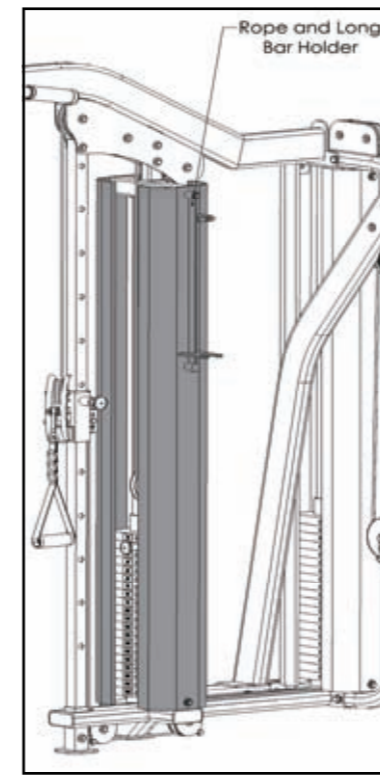

Figure 6

Step 6a:
Repeat step 6 for opposite (Left) side



Item #	Description	Qty
18	Short Bar/Ankle Strap Holder	1
19	Front Shroud	1
20	Rear Shroud	1
21	Rope/Long Bar Holder	1
36	HCS 3/8"-16 x 2 1/4"	1
38	HCS 3/8"-16 x 1/2"	4
39	3/8" Lock Washer	5
41	3/8" Flat Washer	5

All Flat Washers and Nylocks are 3/8" unless otherwise noted.

Step 5 Continued:

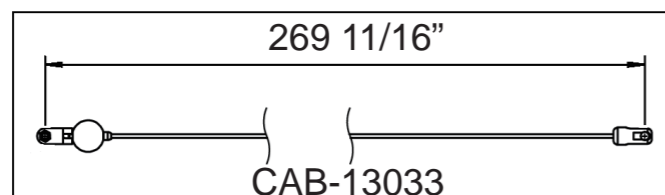
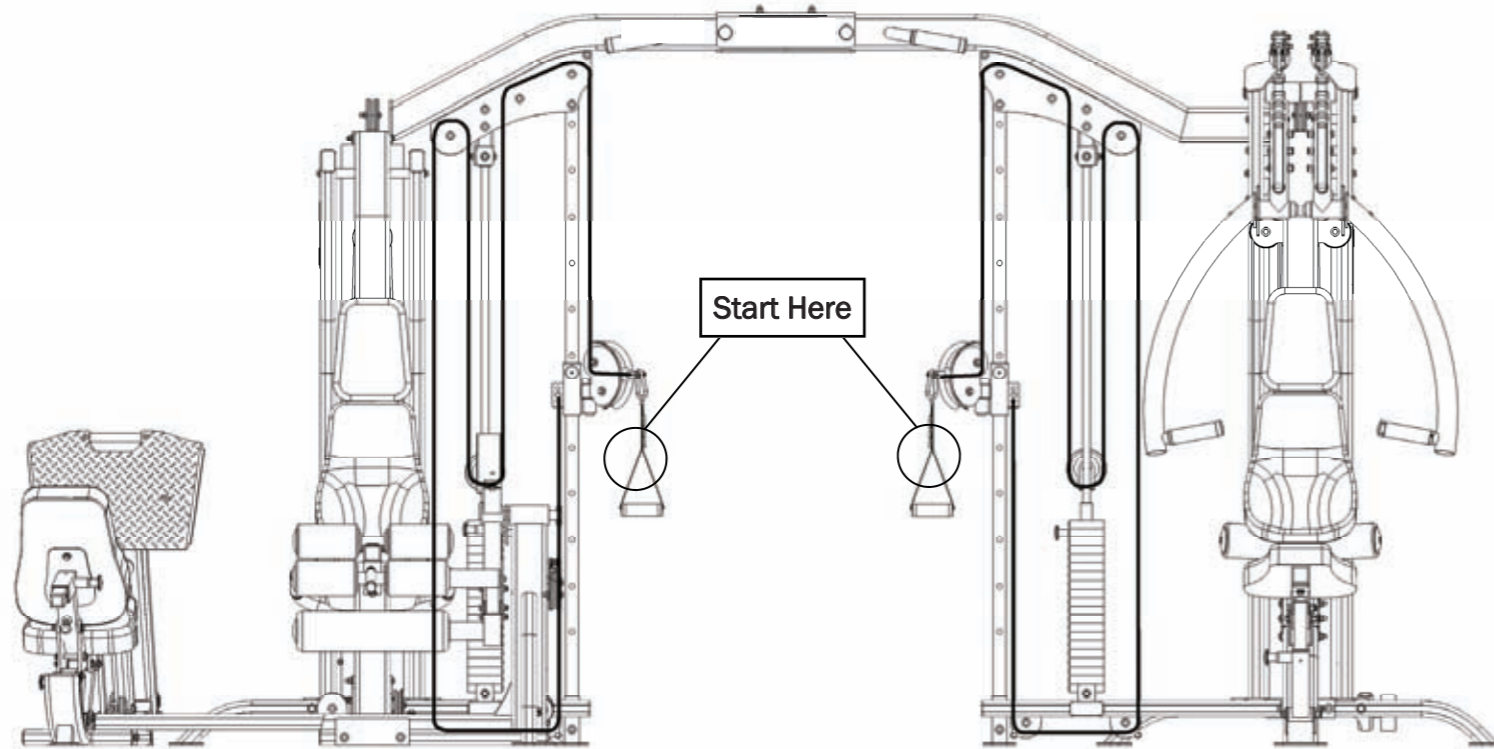

Note: Cables CAB-13033 has a removable Cable Strap end to make cable routing easier. The Cable Strap ends can be found packaged with the hardware.

Step 3:

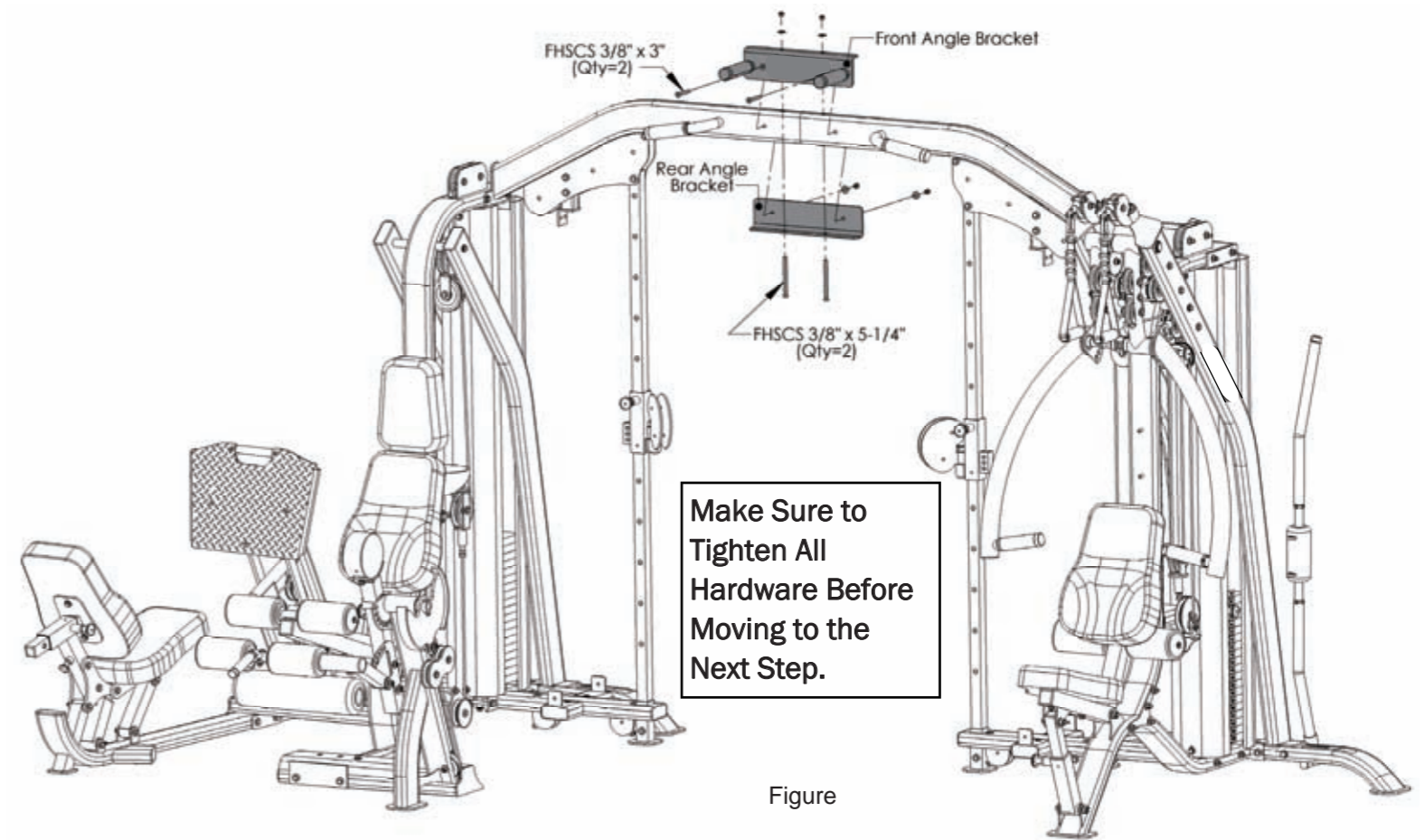

Make Sure to Tighten All Hardware Before Moving to the Next Step.

Figure

Item #	Description	Qty
10	Front Angle Bracket	1
11	Rear Angle Bracket	1
29	FHSCS 3/8"-16 x 3"	2
30	FHSCS 3/8"-16 x 5 1/4"	2
40	3/8" Flat Washer	4
41	3/8" Nylock	4

All Flat Washers and Nylocks are 3/8" unless otherwise noted.

Step 4:

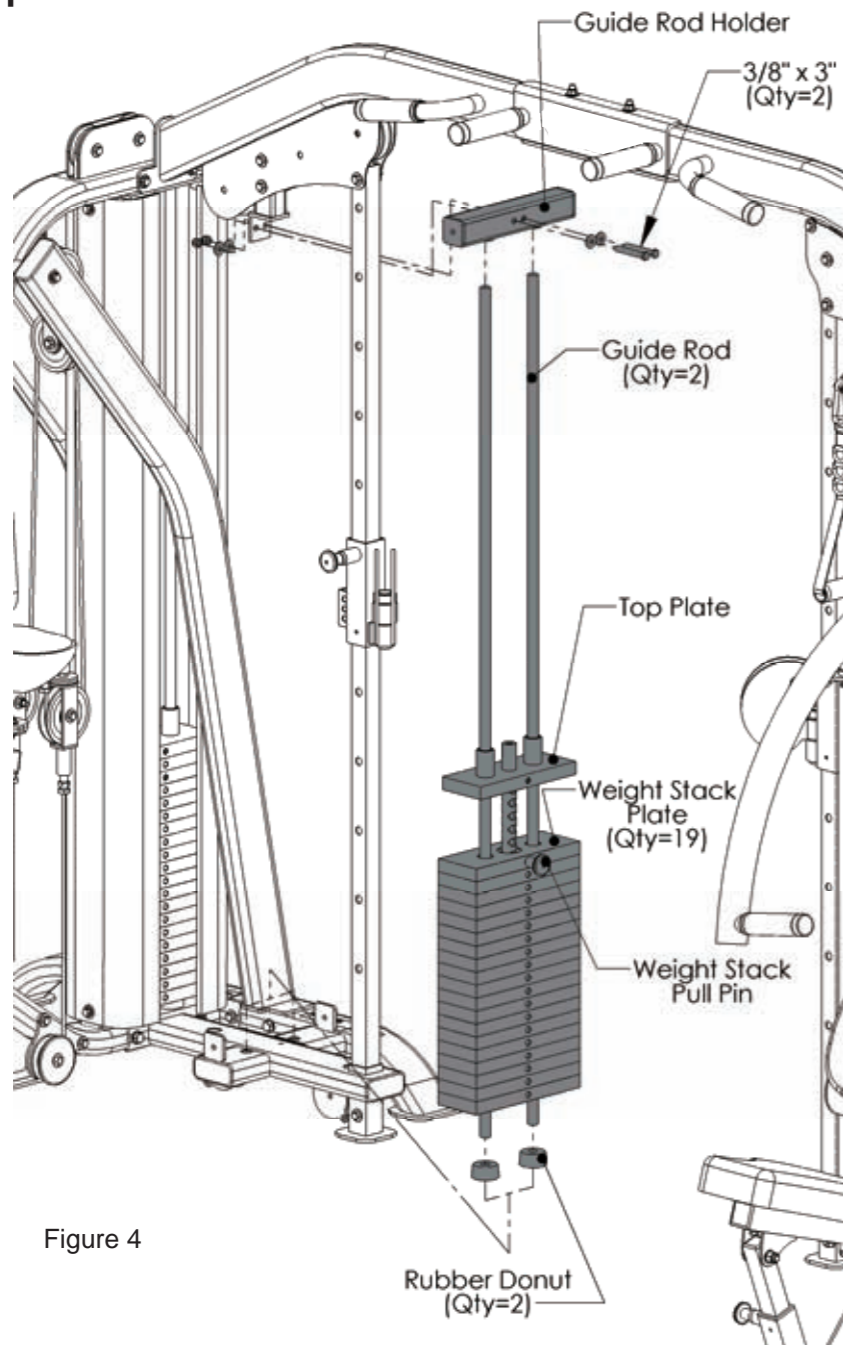
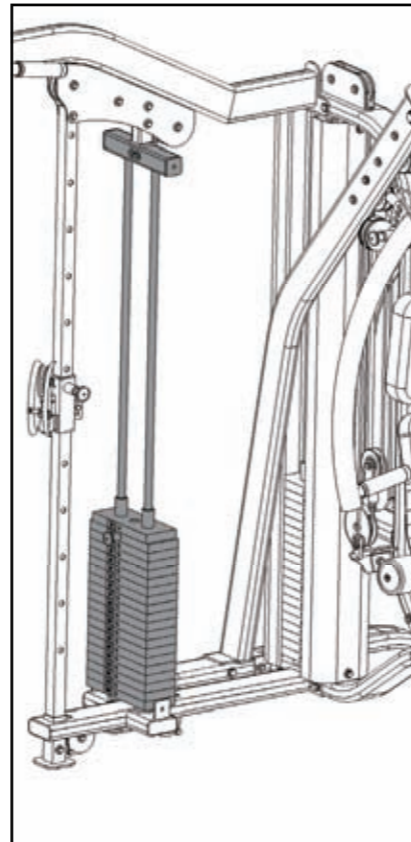

Figure 4

All Flat Washers and Nylocks are 3/8" unless otherwise noted.

Item #	Description	Qty
12	Guide Rod Holder	1
13	Top Plate	1
14	Guide Rod	2
15	Weight Stack Plate	19
16	Rubber Donut	2
22	Weight Stack Pull Pin	1
31	HCS 3/8"-16 x 3"	2
40	3/8" Flat Washer	4
41	3/8" Nylock	2

Step 4a:
Repeat step 4 for opposite (Left) side



Step 5:

⚠ Note: Make Sure Cable is not pinched in between the tube and the pulley support plate. Further cable routing instructions are on the next page.

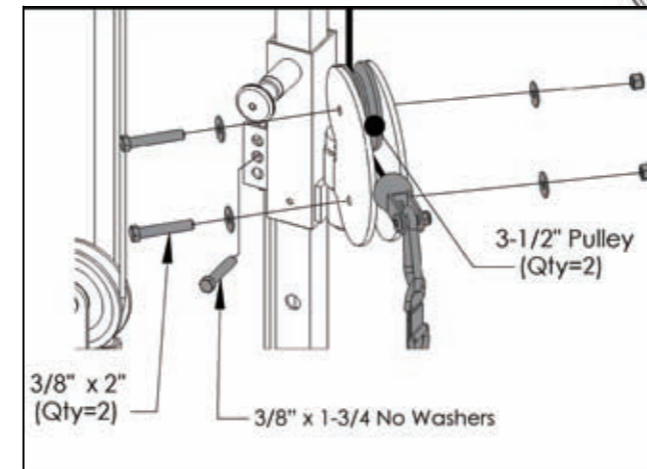

Step 5a:
Repeat step 5 for opposite (Left) side

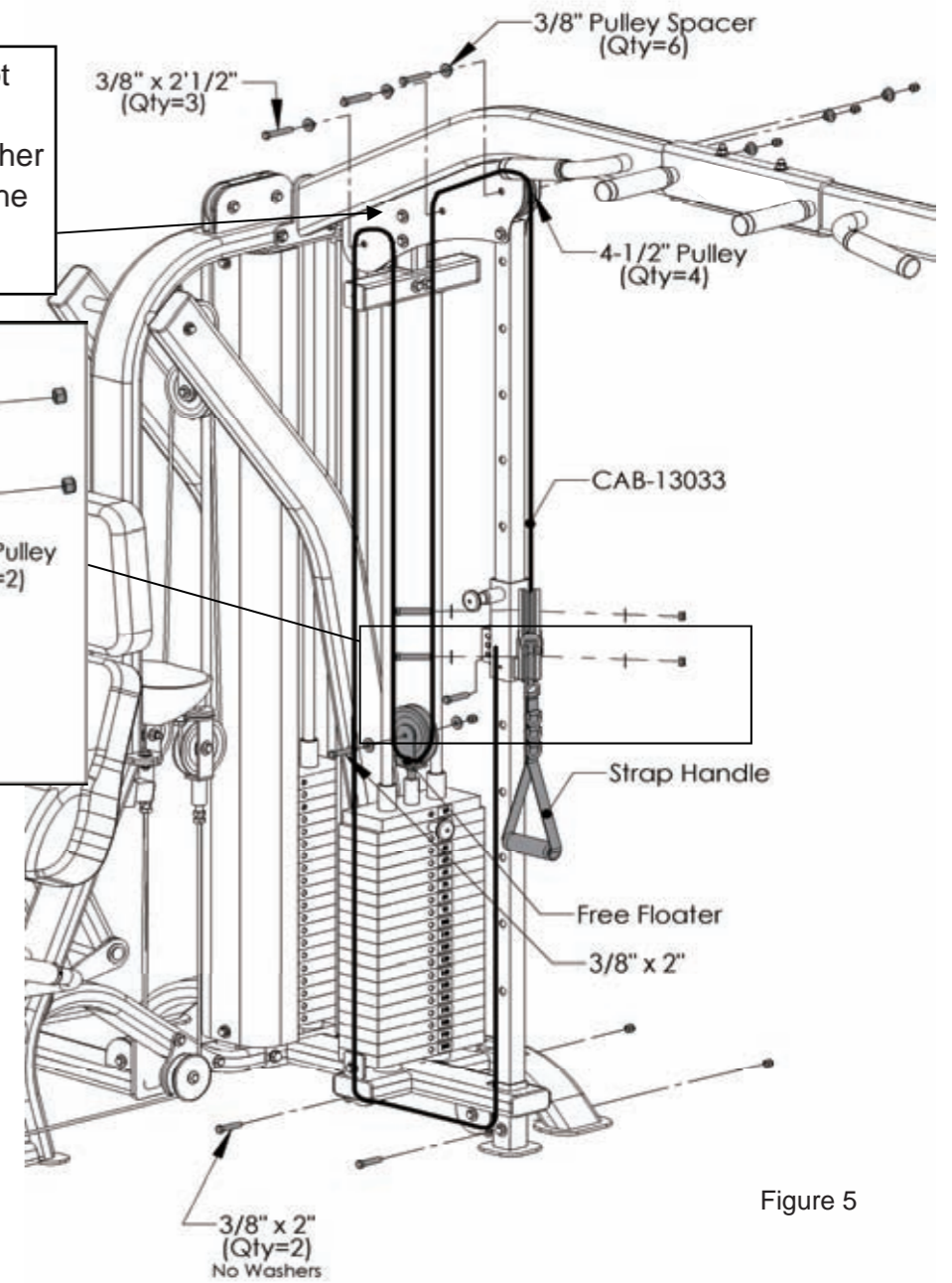
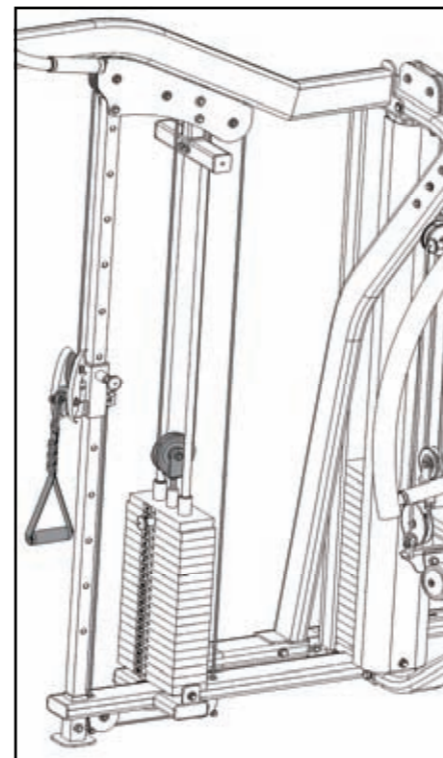

Figure 5

All Flat Washers and Nylocks are 3/8" unless otherwise noted.

Item #	Description	Qty
17	Free Floater (Male)	1
23	Strap Handle	1
24	Functional Trainer Cable	1
27	HCS 3/8"-16 x 2-1/2"	3
32	4 1/2" Pulley	4
33	3 1/2" Pulley	2
34	3/8" Pulley Spacers	6
35	HCS 3/8"-16 x 2"	5
37	HCS 3/8"-16 x 1 3/4"	1
40	3/8" Flat Washer	6
41	3/8" Nylock	9