

Table of Contents

Section Code	Section	Page Number
1	Important Safety Instructions	2
1	Safety Warning Labels and Serial Number	3
1	Specifications	4
1	Moving / Leveling the Machine	5
1	Bluetooth® Heart Rate Armband	6
1	Maintenance	7
1	Maintenance Parts Exploded View	8
1	Troubleshooting - Sections	10
1	No Power / Display Will Not Turn On	11
1	Machine Goes to Sleep While in Use	12
1	Resistance Does Not Respond	13
1	Machine Seized Up	14
1	Machine Slips During Use	15
1	Rollers and Pedals	16
1	Noises - Main	17
1	Noises - Metallic Grinding or Scraping	18
1	Noises - Rubbing / Belt	19
1	Noises - Clicking, Clunking or Knocking	20
1	Noises - Squeaking, Squealing or Chirping	21
1	Contact Heart Rate Issues	22
1	Bluetooth® Heart Rate Issues	23
1	Upper (Drive) Pulley	24
1	Restart the Machine	25
1	Replacement Procedure Skill Level	26
	Mechanical / Modification Procedures	
2	Adjust the Brake Assembly	27
3	Adjust the Leg Assembly Alignment	32
4	Advanced Troubleshooting with Digital Multimeter	35
5	Modify the Resistance Knob Cable	40
	Part Replacement	
6	Replace the Brake Assembly	44
7	Replace the Console Assembly	50
8	Replace the Console Rear Panel	53
9	Replace the Crank Arm, Left	57
10	Replace the Crank Arm, Right	61
11	Replace the Drive Belt	66
12	Replace the Drive Pulley	71
13	Replace the Drive Pulley Hardware	78
14	Replace the Fan Assembly	83
15	Replace the Fan Belt	86
16	Replace the Fan Pulley	93
17	Replace the Frame Assembly	101
18	Replace the Handlebar Pivot Assembly	110
19	Replace the Mid Mast Cables	112
20	Replace the Power Inlet	117
21	Replace the Roller Wheel Assembly	120
22	Replace the Servo Motor	122
23	Replace the Shrouds	127
24	Replace the Speed Sensor Assembly	132
25	Replace the Static Handlebar Assembly	135
26	Replace the Upper Body Sensor Assembly	138
27	Replace the Wiring Harness, Main	146

NOTICE: This document provides important safety instructions, adjustments, and general troubleshooting information for the maintenance of the Bowflex™ Max Total™ machine.

If you need assistance, please contact Customer Service (if purchased in US/Canada) or your local distributor (if purchased outside US/Canada). To find your local distributor, go to: www.nautilusinternational.com



This icon means a potentially hazardous situation which, if not avoided, could result in death or serious injury. Read and understand all Warnings on this machine.

Nautilus, Inc., (800) 605-3369, www.NautilusInc.com - Customer Service: North America (800) 605-3369, csnls@nautilus.com | outside U.S. www.nautilusinternational.com | Printed in China | © 2019 Nautilus, Inc. | Bowflex, the B logo, JRNY, and Max Total are trademarks owned or licensed by Nautilus, Inc., registered or otherwise protected by common law in the United States and other nations. App Store is a service mark of Apple Inc. The Bluetooth® word mark and logos are registered trademarks owned by Bluetooth SIG, Inc., and any use of such marks by Nautilus, Inc. is under license. | **ORIGINAL DOCUMENT - ENGLISH VERSION ONLY**

Important Safety Instructions



This icon means a potentially hazardous situation which, if not avoided, could result in death or serious injury. Read and understand all Warnings on this machine.

Before servicing or using this equipment, obey the following warnings:



Read and understand the Service Manual before working on the machine. Failure to obey the instructions and safety warnings could cause injury to the service technician or bystanders.

! DANGER

To reduce the risk of electrical shock or unsupervised usage of the equipment, always unplug the power cord from the wall outlet and/or the machine before cleaning, maintaining or repairing the machine. Place the power cord in a secure location.

- Keep bystanders and children away from the product being serviced at all times.
- Make sure that the repair is done in an appropriate work space away from foot traffic and exposure to bystanders.
- Some components of the equipment can be heavy or awkward. Enlist the service of a second person when you do maintenance steps involving these components. Do not try to do heavy or awkward steps on your own.
- Use only replacement parts and hardware that are supplied or approved by Nautilus. Failure to use Nautilus-approved replacement parts can adversely affect the safety and functionality of the equipment creating a risk to users and will void the warranty.
- Be sure that all warning stickers and instructional placards applied to the product stay present and in good condition when doing maintenance or replacing components. If at any time the Warning labels become loose, unreadable or dislodged, replace the labels. If purchased in US/Canada, contact Customer Service for replacement labels. If purchased outside US/Canada, contact your local distributor for them.
- Do not try to change the design or functionality of the machine being serviced as this can adversely affect user safety and will void the warranty.
- Do not put the machine back in service until all shrouds, instructions, warning labels and correct functionality have been verified and tested for correct performance.

• SAVE THESE INSTRUCTIONS.

SAFETY WARNING LABELS AND SERIAL NUMBER

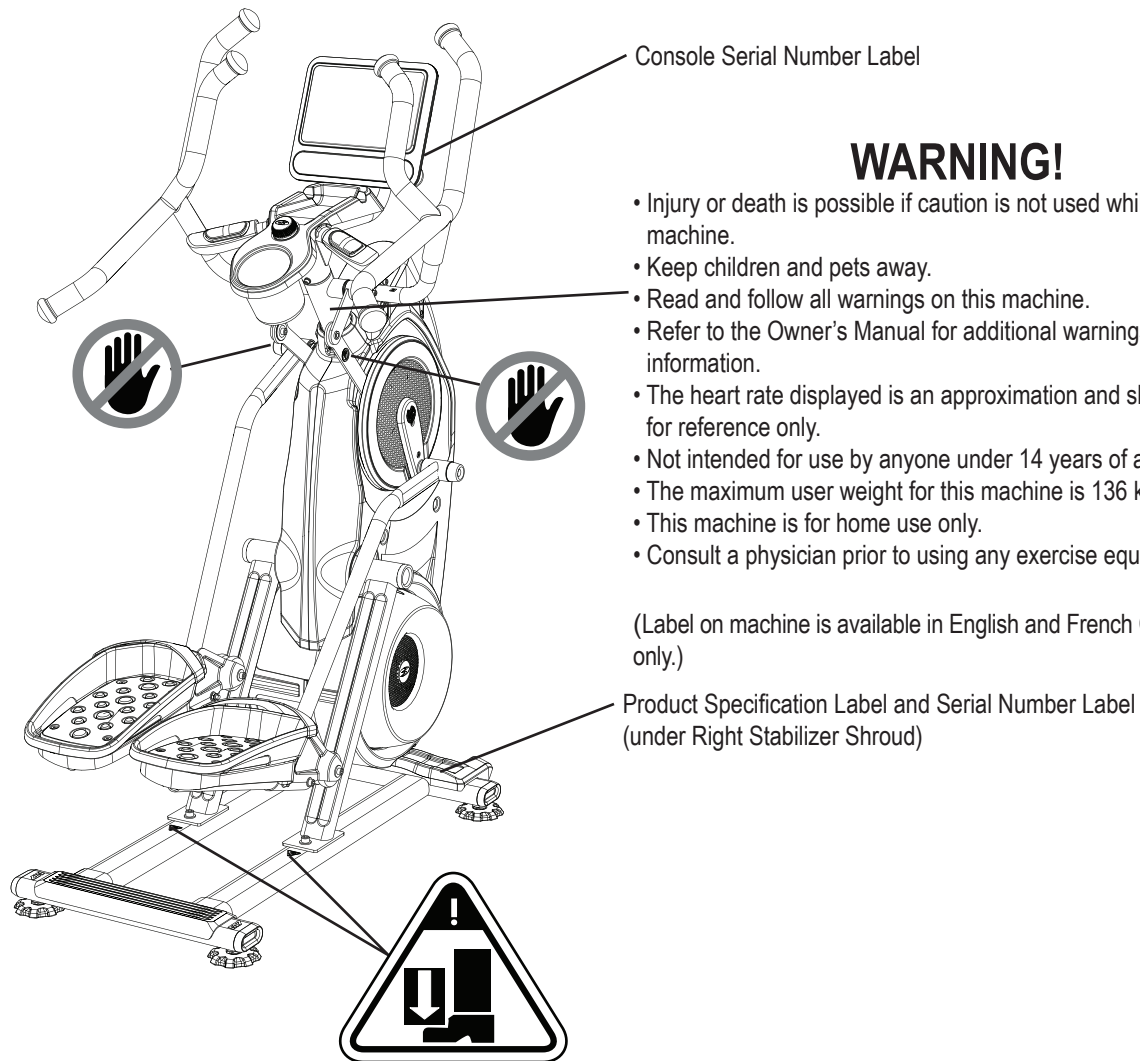

WARNING!

- Injury or death is possible if caution is not used while using this machine.
- Keep children and pets away.
- Read and follow all warnings on this machine.
- Refer to the Owner's Manual for additional warnings and safety information.
- The heart rate displayed is an approximation and should be used for reference only.
- Not intended for use by anyone under 14 years of age.
- The maximum user weight for this machine is 136 kg. (300 lbs)
- This machine is for home use only.
- Consult a physician prior to using any exercise equipment.

(Label on machine is available in English and French Canadian only.)

Product Specification Label and Serial Number Label
(under Right Stabilizer Shroud)

FCC Compliance

⚠ Changes or modifications to this unit not expressly approved by the party responsible for compliance could void the user's authority to operate the equipment.

The machine and power supply comply with part 15 of the FCC rules. Operation is subject to the following two conditions: (1) This device may not cause harmful interference, and (2) this device must accept any interference received, including interference that may cause undesired operation.

Note: This machine and power supply have been tested and found to comply with the limits for a Class A digital device, pursuant to Part 15 of the FCC Rules. These limits are designed to provide reasonable protection against harmful interference in a residential installation. This equipment generates, uses and can radiate radio frequency energy and, if not installed and used in accordance with the instructions, may cause harmful interference to radio communications.

However, there is no guarantee that interference will not occur in a particular installation. If this equipment does cause harmful interference to radio or television reception, which can be determined by turning the equipment off and on, the user is encouraged to try to correct the interference by one or more of the following measures:

- Reorient or relocate the receiving antenna.
- Increase the separation between the equipment and receiver.
- Connect the equipment into an outlet on a circuit different from that to which the receiver is connected.
- Consult the dealer or an experienced radio/TV technician for help.

This product complies with the European Radio Equipment Directive 2014/53/EU

SPECIFICATIONS

- Maximum User Weight:** 136 kg (300 lbs.)
- Total Surface Area (footprint) of equipment:** 9648.8 cm² (1494.5 in²)
- Maximum Pedal Height:** 48.5 cm (19.1 inches)
- Machine Weight:** 67.1 kg (148 lbs.)
- Power Requirements:**
 - (AC Adaptor)**
 - Input Voltage: 100-240V AC, 50-60Hz, 1.5A
 - Output Voltage: 12V DC, 5A
 - Heart Rate Armband: 1 Lithium battery (not replaceable)
 - Console: 1 Lithium battery (not replaceable)

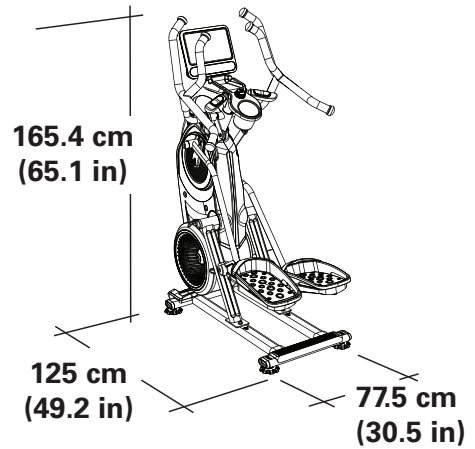

DO NOT dispose of this product as refuse. This product is to be recycled. For proper disposal of this product, please follow the prescribed methods at an approved waste center.

For safe operation, the location must be on a hard, level surface. Allow a workout area of a minimum 137.5 cm (54.1 in) x 185 cm (72.3 in). Keep the workout area clear 0.6 m (24 in) along the side used to access the machine and to the rear of the machine. Be sure that the workout space you are utilizing has adequate height clearance, taking into consideration the height of the user and the maximum pedal height of the fitness machine.

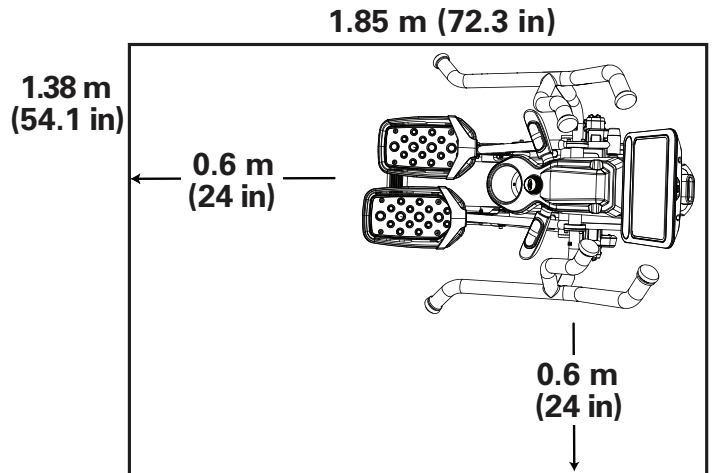

Moving the Machine

! The machine may be moved by one or more persons depending on their physical abilities and capacities. Make sure that you and others are all physically fit and able to move the machine safely.

1. Grasp the Main Bar of the Static Handlebar Assembly to carefully tilt the machine toward you onto the transport rollers. Be sure not to grab the Console Display.

! Be aware of the Handlebars and the weight of the machine before tilting the machine.

2. Push the machine into position.
3. Carefully lower the machine into position.

NOTICE: Be careful when you move the machine. All abrupt motions can affect the computer operation.

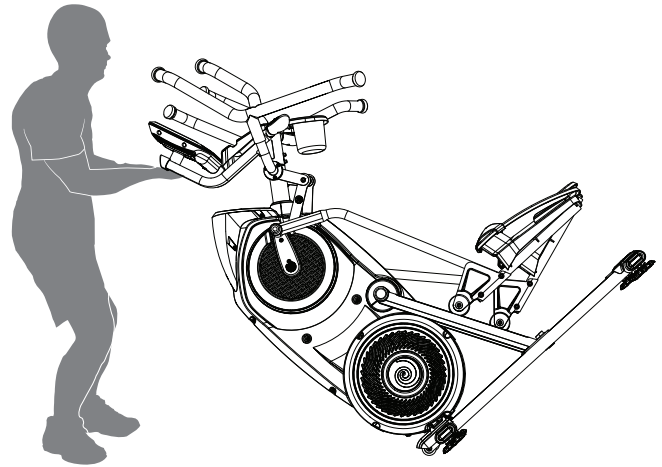

Leveling the Machine

The machine needs to be leveled if your workout area is uneven or if the Rail Assembly is slightly off the floor. To adjust:

1. Place the machine in your workout area.
2. Loosen the locking nuts and adjust the levelers until they are evenly balanced in contact with the floor.

! Do not adjust the levelers to such a height that they detach or unscrew from the machine. Injury to you or damage to the machine can occur.

3. Tighten the locking nuts.

! Make sure the machine is level and stable before you exercise.

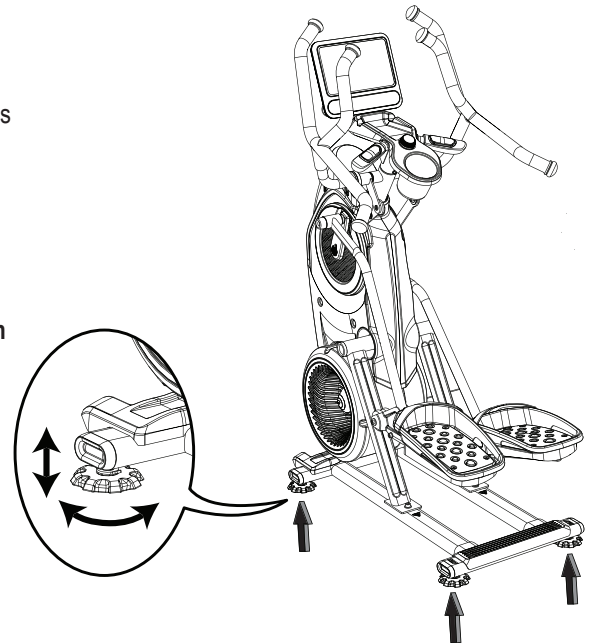

USB Charging

If a USB Device is attached to the USB Port, the Port will attempt to charge the Device.

The power supplied from the USB Port may not be enough to operate the Device and charge it at the same time.

Media Rack (Optional Accessory)

An optional accessory can be added to your fitness machine that will hold additional media above the Console. The optional Media Rack easily attaches to your machine, adding more space for media and devices.

To order the optional Media Rack, contact Customer Service (if in US/Canada) or your local distributor (if outside US/Canada).

Speakers

To play audio through the speakers on your machine, open an App on the Console and allow it to stream audio.

Note: Though your machine is Bluetooth® enabled, it is unable to receive and play audio across a Bluetooth® connection from your device or stream audio from the machine to your Bluetooth® device (such as Bluetooth® headphones).

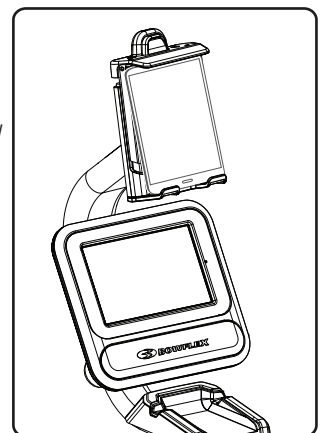

Using the Bowflex™ JRNY™ App on your Portable Device (Optional)

Though you can access your completed workout information from your console with your JRNY™ membership, you can also access this information remotely on your own device. Simply download the JRNY™ app to your device for access to your JRNY™ membership.

1. Download the app, named "Bowflex™ JRNY™ App". The app is available on Google Play™ and the App Store.

Note: For a complete list of supported devices, review the app on the App Store or Google Play™.

2. Follow the instructions on the app to sync your device to your Bowflex™ JRNY™ membership.

When your device has access to the account, you will be able to review past workouts, coaching, and upcoming workouts with your JRNY™ membership*.

Bluetooth® Heart Rate Armband

Your fitness machine is provided with a Bluetooth® Heart Rate Armband. When the Bluetooth® Heart Rate Armband is connected, the Console will display the Bluetooth® Heart Rate Device icon.

⚠️ If you have a pacemaker or other implanted electronic device, consult your doctor before using a Bluetooth® armband or other Bluetooth® heart rate monitor.

The Heart Rate Armband should be worn on the upper portion of your forearm, with the Heart Rate Sensor to the inside of your forearm. It should be snug enough not to move around on your arm, but not so tight that it restricts blood circulation.

Note: Be sure to remove the protective cover from the Heart Rate Sensor before use.

1. Put the Bluetooth® Heart Rate Armband onto the upper portion of your forearm.
2. Confirm that Bluetooth® is active on the machine. If the Bluetooth® icon is blue, then it is active.

If the icon is red, then Bluetooth® must be activated. To activate Bluetooth®:

- a. Tap the Bluetooth® icon.
 - b. Tap "Manage Bluetooth®".
 - c. Slide the option from "OFF" to "ON".
 - d. Tap Back to exit.
3. When ready to exercise, start your workout.
 4. Push the On/Off LED button on the Heart Rate Armband. Be sure to only push the On/Off LED button once.
 5. During your workout, the Heart Rate Armband may take up to 60 seconds to connect. When connected, the Bluetooth® Heart Rate Device icon will be displayed along with your heart rate.

Note: The Armband can only be connected once to an active workout. If the On/Off LED button is pushed after being connected, the workout must be restarted.

At the end of your workout, push the On/Off LED button to disconnect and deactivate your Heart Rate Armband.

If you press the On/Off LED button and the LED flashes red several times, the battery is low and should be charged. To charge the Bluetooth® Heart Rate Armband, connect the Charging Cable to the Charging Terminals on the inside of the Sensor. Connect the Charging Cable to a powered USB Port. The LED will flash red and green while charging. When fully charged, the LED will be green continuously.

* A JRNY™ membership is required for the JRNY™ experience – see www.bowflex.com/jrny for details. For United States and Canada customers, you can obtain a JRNY™ membership by calling 800-269-4126 or visiting www.bowflex.com/jrny. Where available (including the United States), you can also obtain a JRNY™ membership by downloading the JRNY™ app onto your phone or tablet and signing up within the downloaded app. JRNY™ memberships may not be available in all countries.

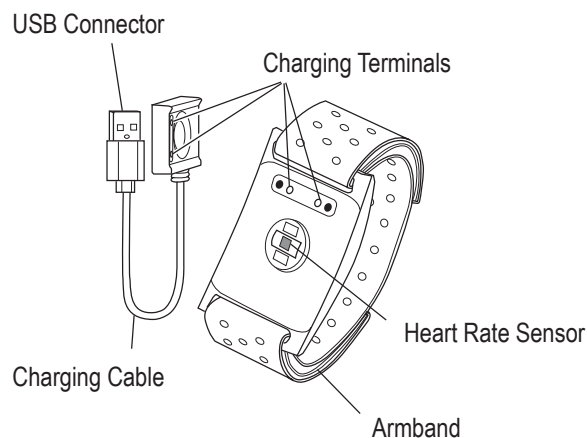
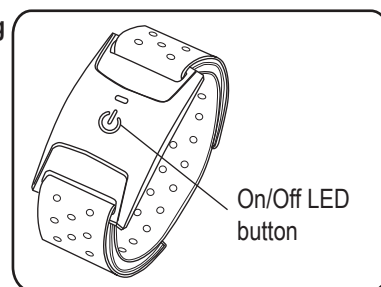

MAINTENANCE

Read all maintenance instructions fully before you start any repair work. In some conditions, an assistant is required to do the necessary tasks.

 **Equipment must be regularly examined for damage and repairs. The owner is responsible to make sure that regular maintenance is done. Worn or damaged components must be repaired or replaced immediately. Only manufacturer supplied components can be used to maintain and repair the equipment.**

If at any time the Warning labels become loose, unreadable or dislodged, replace the labels. If purchased in US/Canada, contact Customer Service for replacement labels. If purchased outside US/Canada, contact your local distributor for them.

To reduce the risk of electrical shock or unattended/unsupervised usage, always unplug the power cord from the wall outlet and the machine and wait 5 minutes before cleaning, maintaining or repairing the machine. Place the power cord in a secure location.

Daily: Before each use, examine the exercise machine for loose, broken, damaged, or worn parts. Do not use if found in this condition. Repair or replace all parts at the first sign of wear or damage. After each workout, use a damp cloth to wipe your machine and Console free of sweat.

Note: Avoid excessive moisture on the Console.

Weekly: Check for smooth roller operation. Wipe the machine to remove dust, dirt, or grime. Clean the rails and surface of the rollers with a damp cloth.

Apply silicone lubricant to a dry cloth and wipe the rails to eliminate roller noise.

 **Silicone lubricant is not intended for human consumption. Keep out of reach of children. Store in a safe place.**

Note: Do not use petroleum based products.

**Monthly
or after 20
hours:**

Make sure all bolts and screws are tight. Tighten as necessary.

NOTICE: If necessary, only use a mild dish soap with a soft cloth to clean the Console. Do not clean with a petroleum based solvent, automotive cleaner, or any product that contains ammonia. Do not clean the Console in direct sunlight or at high temperatures. Be sure to keep the Console free of moisture.

Maintenance Parts

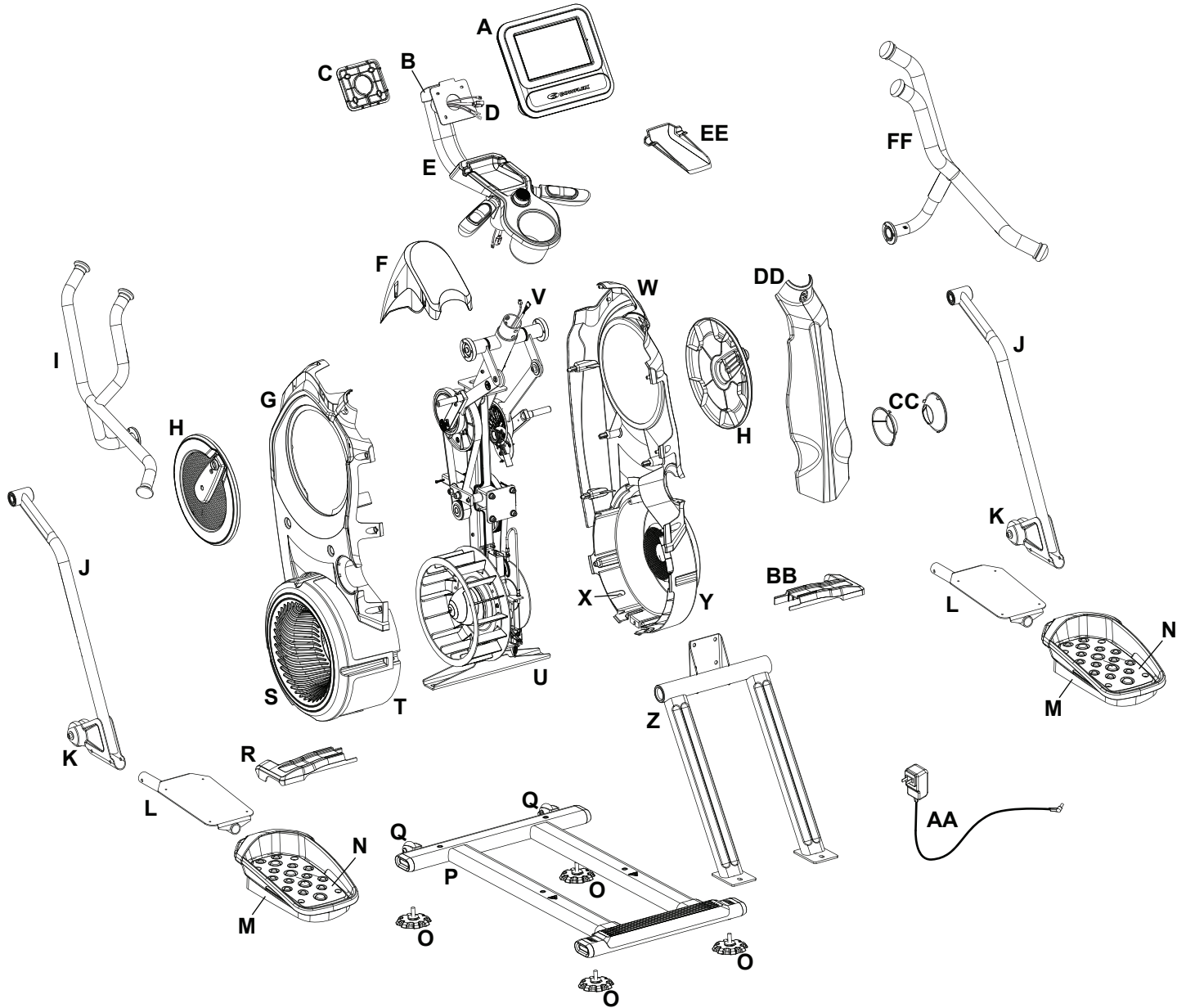

A	Console Assembly	K	Pedal	U	Rail Assembly
B	Console Rear Cover	L	Foot Pad	V	Shroud, Right Fan
C	Static Handlebars	M	Foot Pad Insert	W	Shroud, Right
D	Static Handlebar Cap	N	Leveler	X	Stabilizer Shroud, Right
E	Upper Shroud	O	Stabilizer	Y	Shroud, Rear
F	Shroud, Left	P	Transport Wheel	Z	Cap
G	Crank Cover	Q	Stabilizer Shroud, Left	AA	Dynamic Handlebar, Right
H	Dynamic Handlebar, Left	R	Shroud, Left Fan	BB	Power Inlet
I	Leg	S	Fan Assembly Inserts	CC	AC Adapter
J	Roller	T	Frame Assembly	DD	Tray Insert

EE	Arm Drive Assembly
FF	Crank Arm, Left
GG	Drive Pulley, Upper
HH	Drive Belt
II	Tensioner
JJ	Fan Assembly
KK	Speed Sensor
LL	Disc Brake
MM	Fan Belt
NN	Drive Pulley, Lower
OO	Crank Arm, Right
PP	Upper Body Sensor

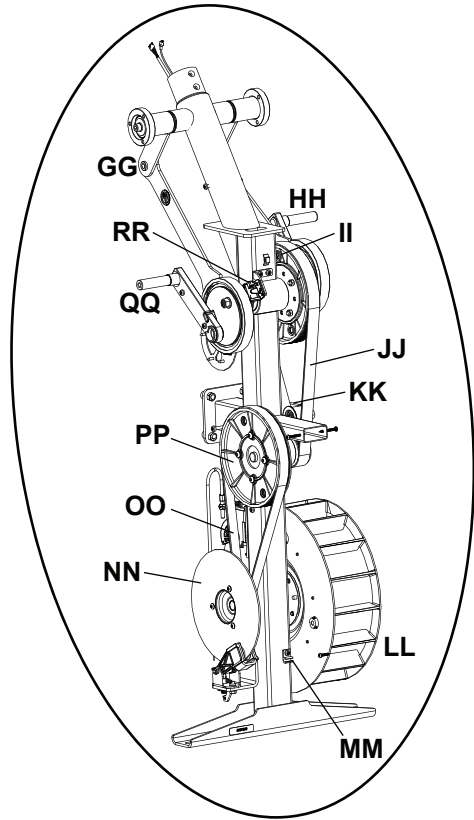

Troubleshooting - Sections

- A. No Power / Display Will Not Turn On
- B. Machine Goes to Sleep While in Use
- C. Resistance Does Not Respond
- D. Machine Seized Up
- E. Machine Slips During Use
- F. Rollers and Pedals
- G. Noises - Main
 - H. - Metallic Grinding or Scraping
 - I. - Rubbing / Belt
 - J. - Clicking, Clunking or Knocking
 - K. - Squeaking, Squealing or Chirping
- L. Contact Heart Rate
- M. Bluetooth® Heart Rate
- N. Upper (Drive) Pulley

No Power / Display Will Not Turn On

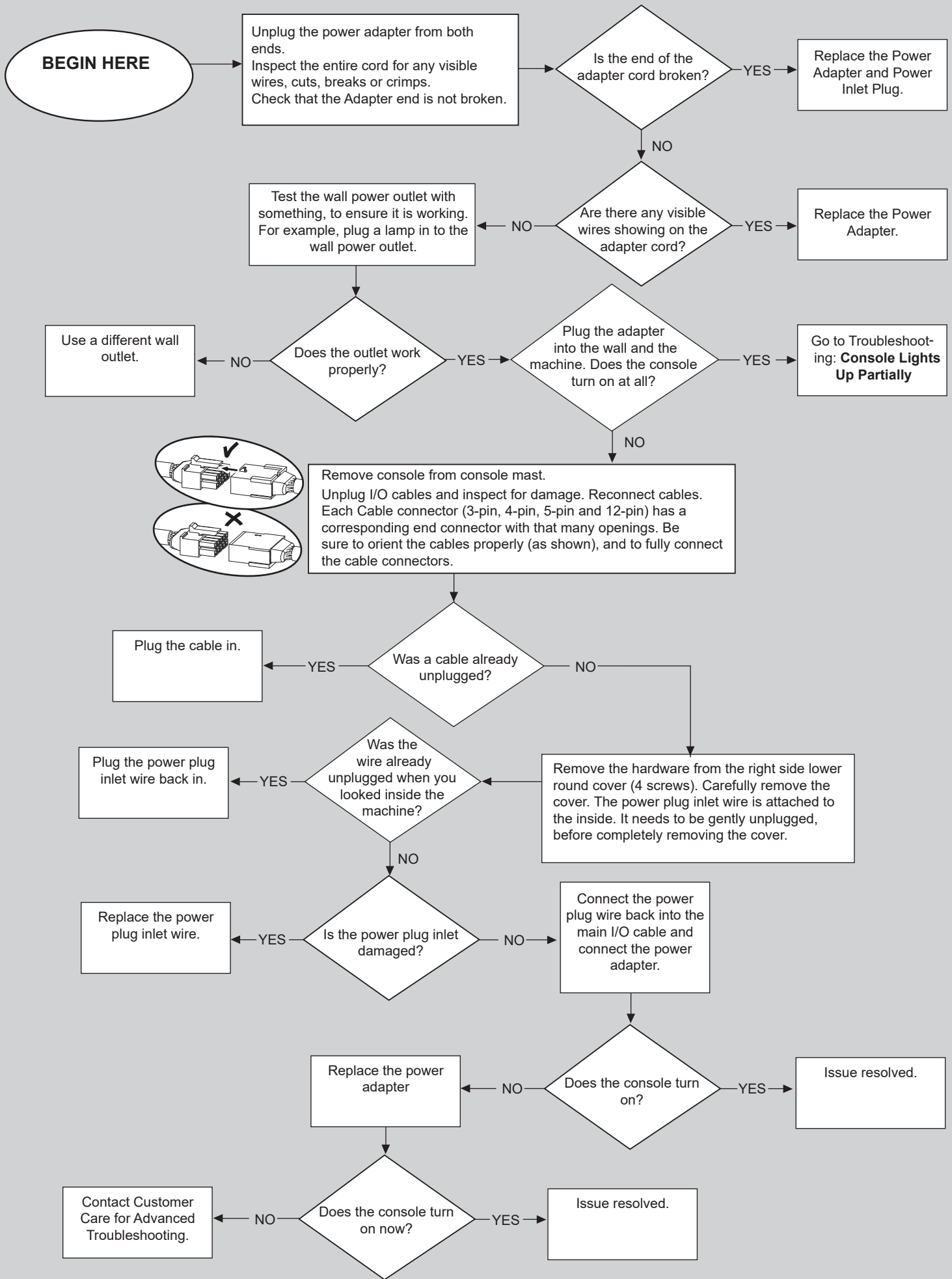

Machine Goes to Sleep While in Use

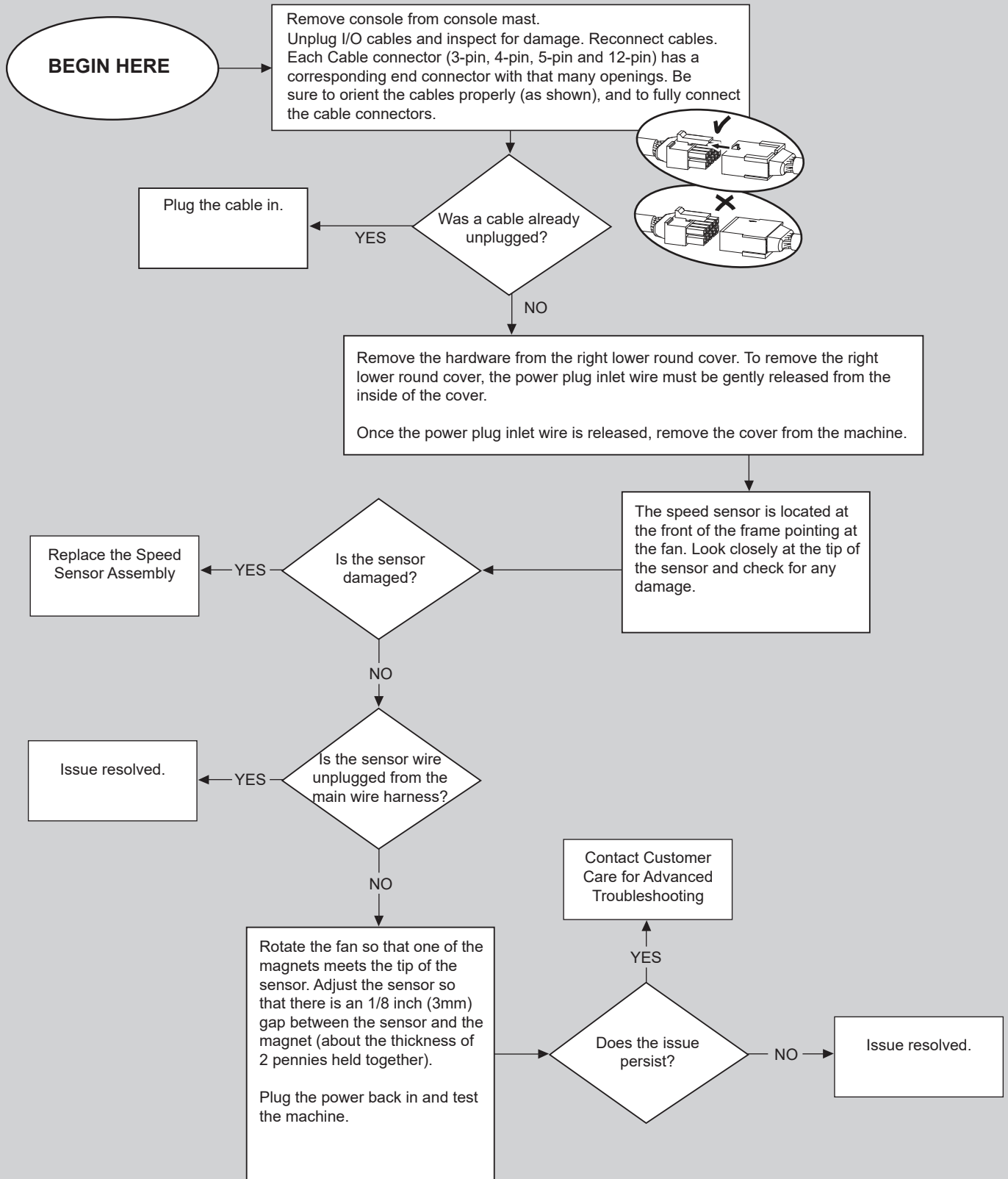

Resistance Does Not Respond

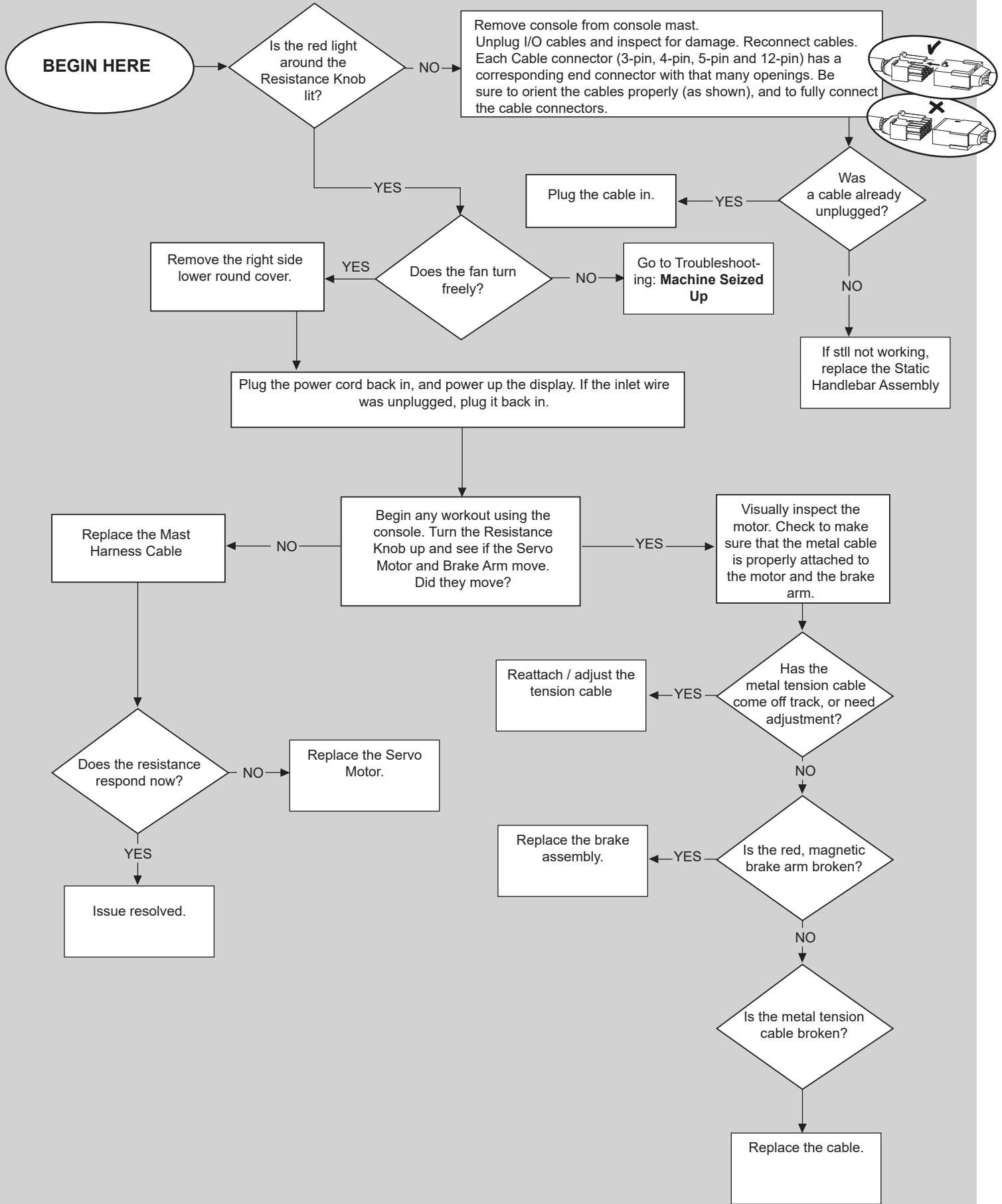

Machine Seized Up

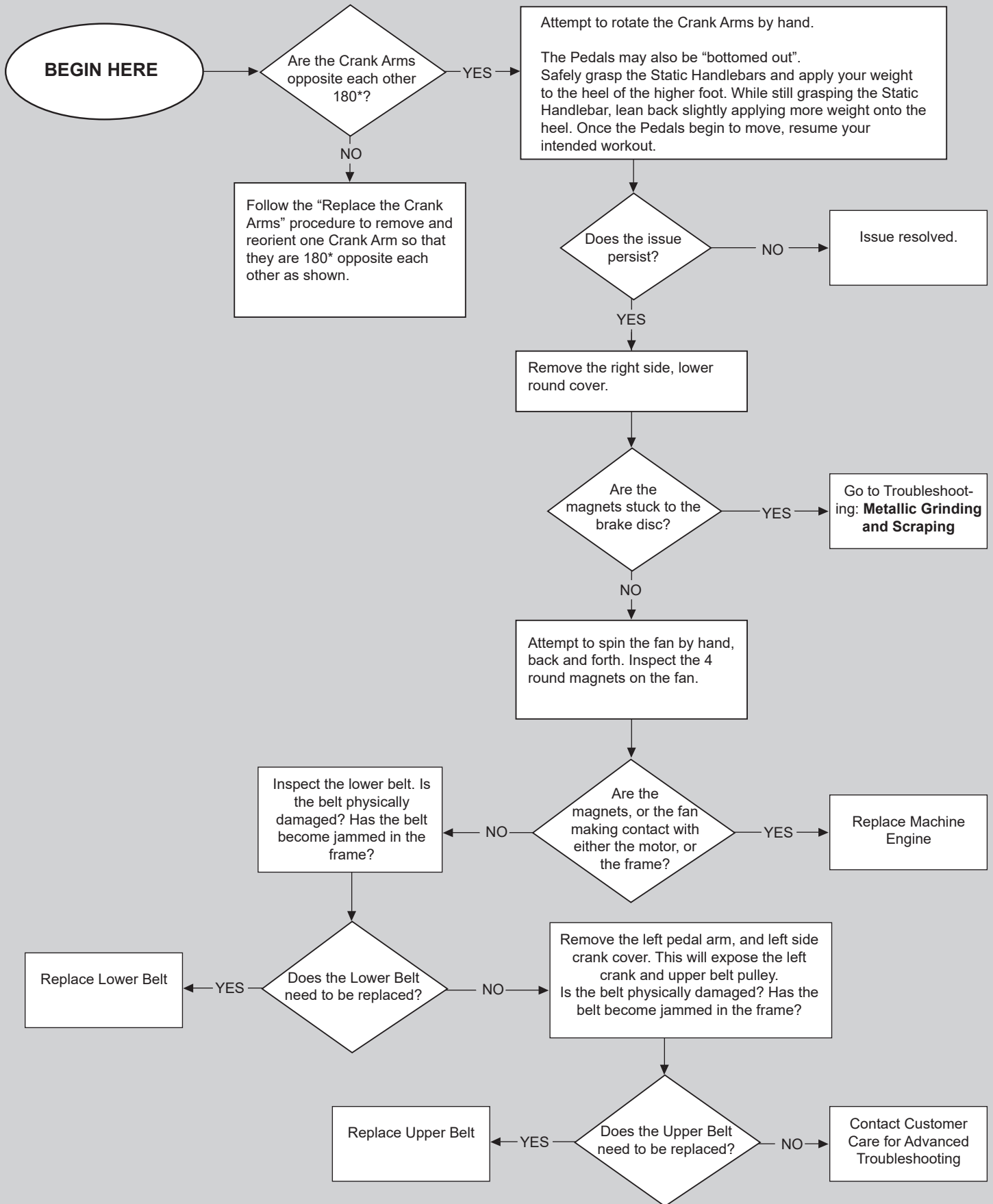

Machine Slips During Use

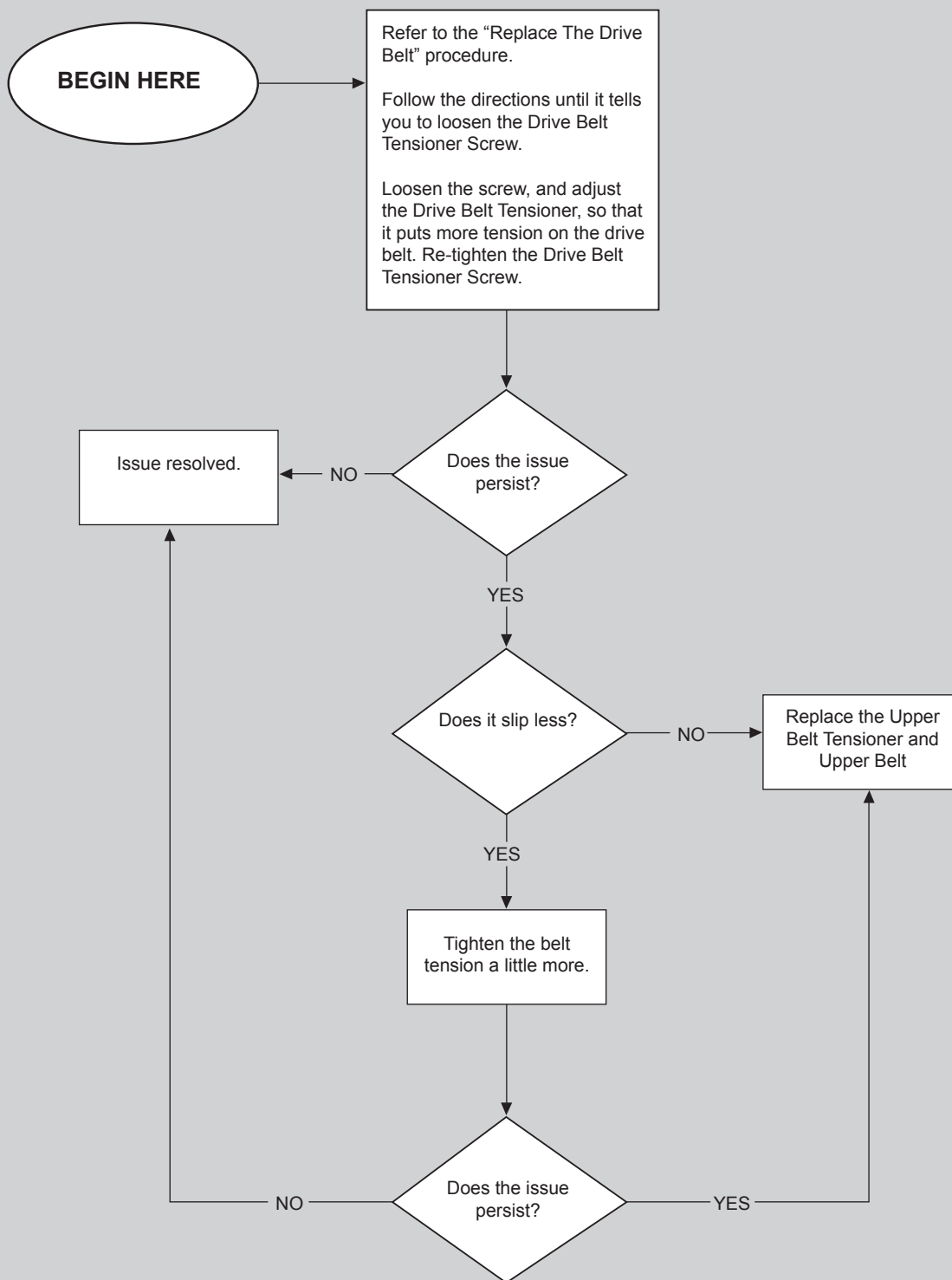

Rollers and Pedals

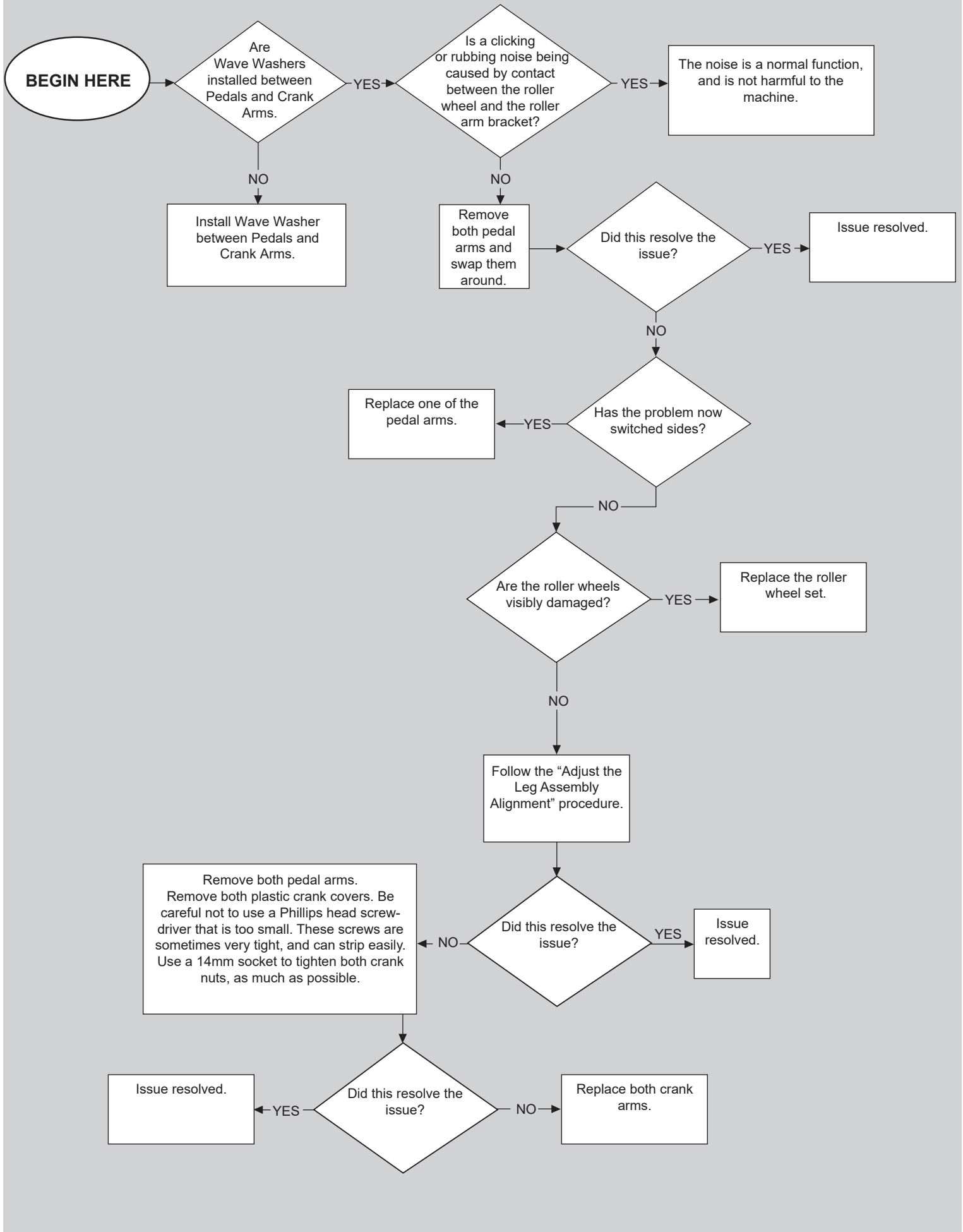

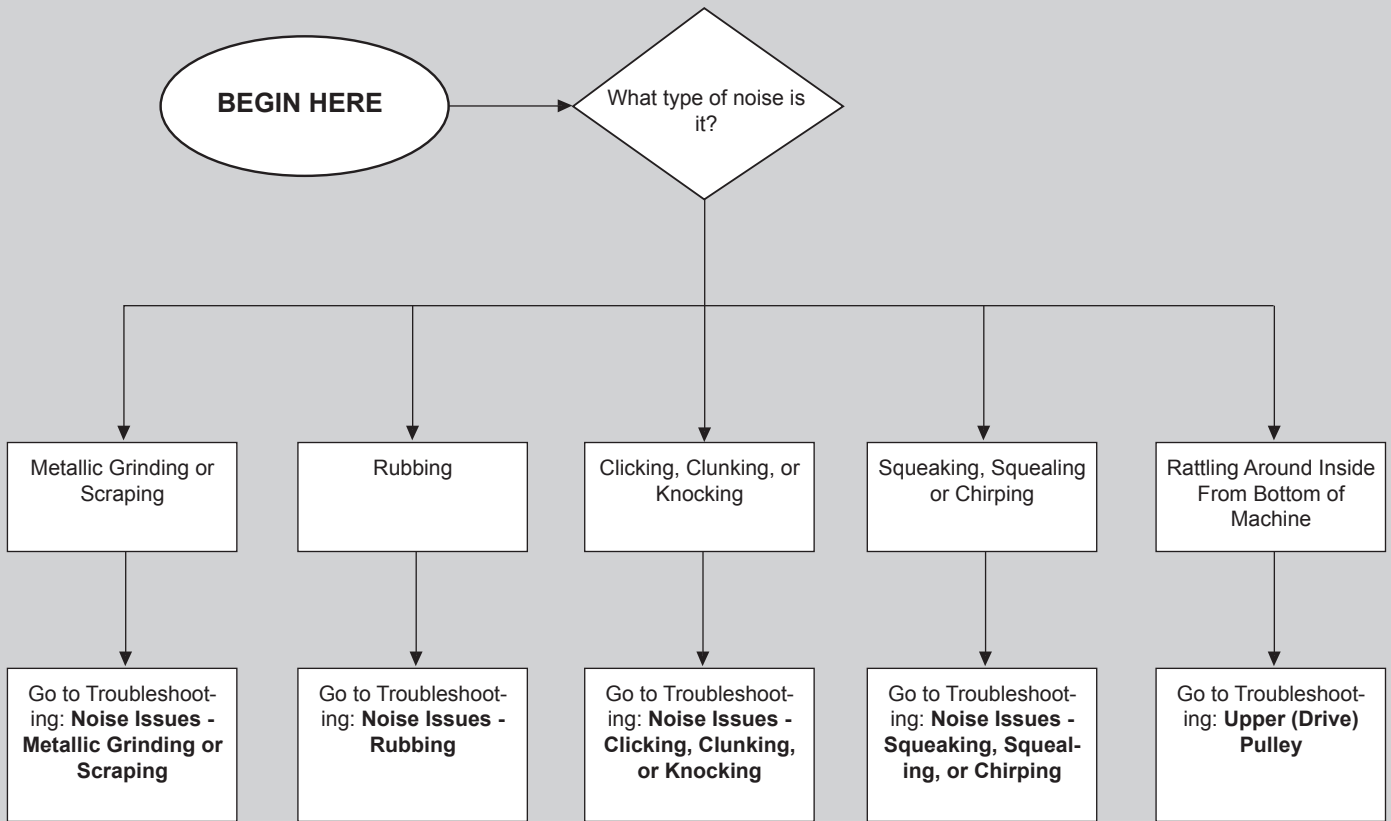

Noise Issues - Metallic Grinding or Scraping

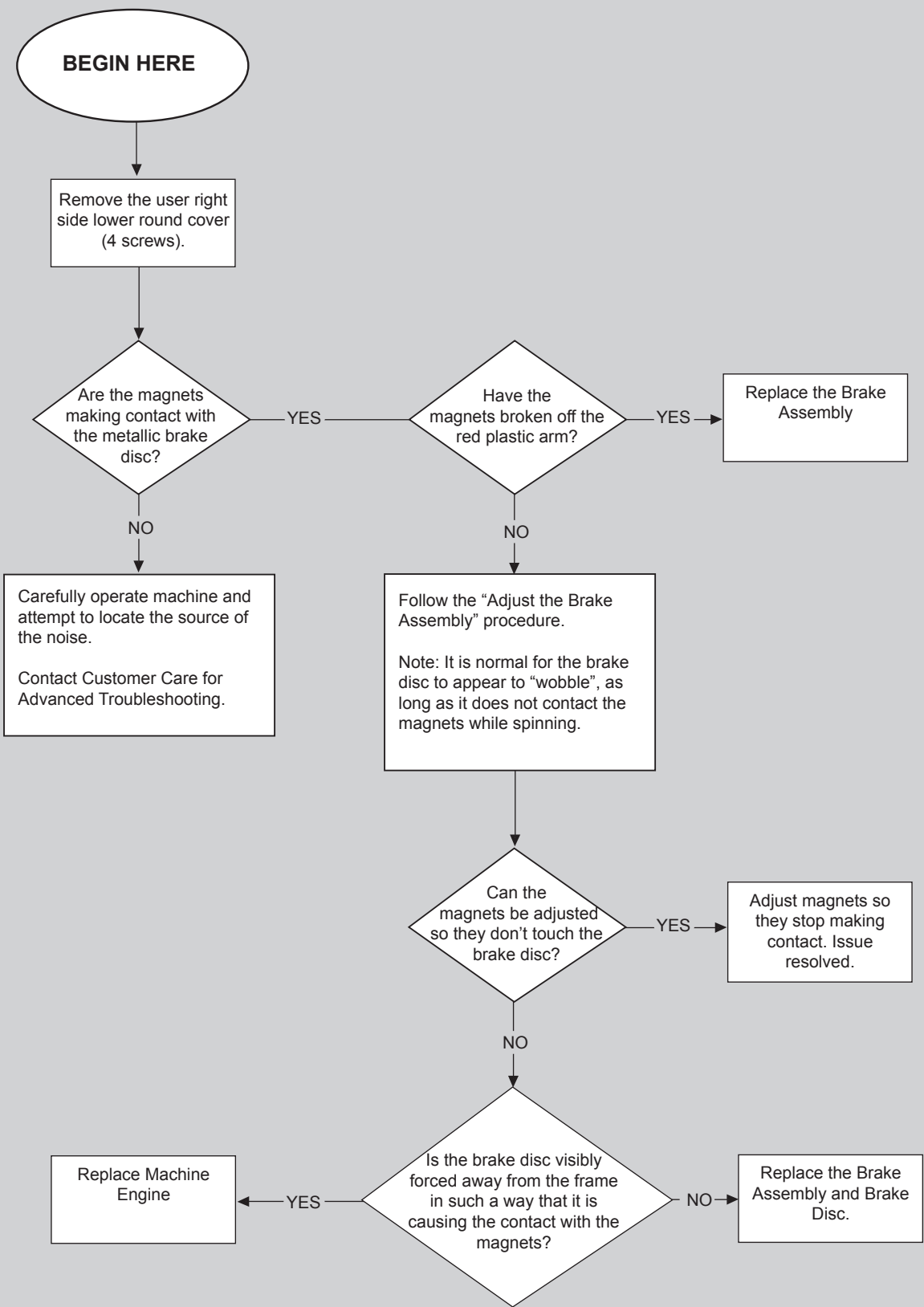

Noise Issues - Rubbing / Belt

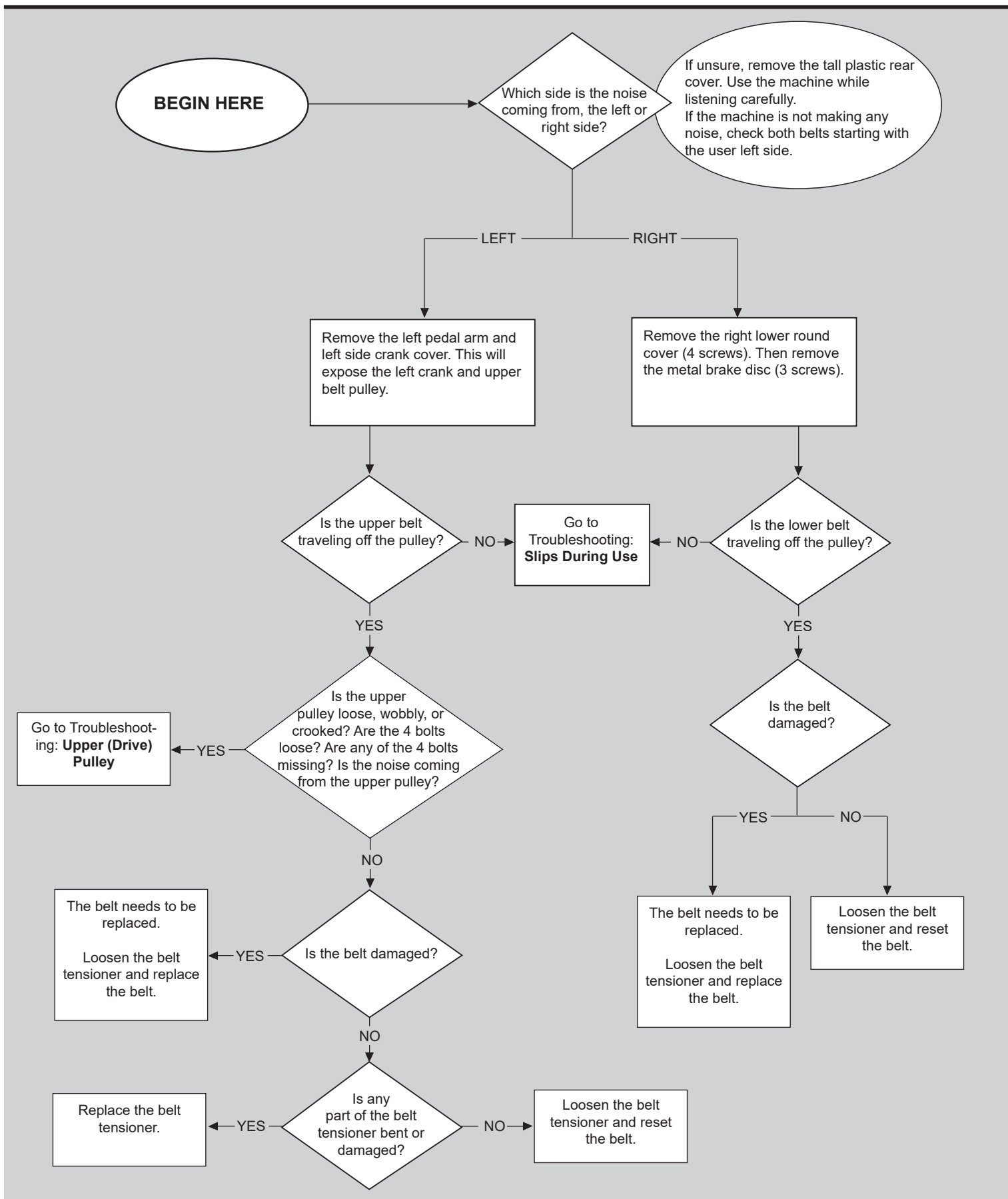

Noise Issues - Clicking, Clunking, or Knocking

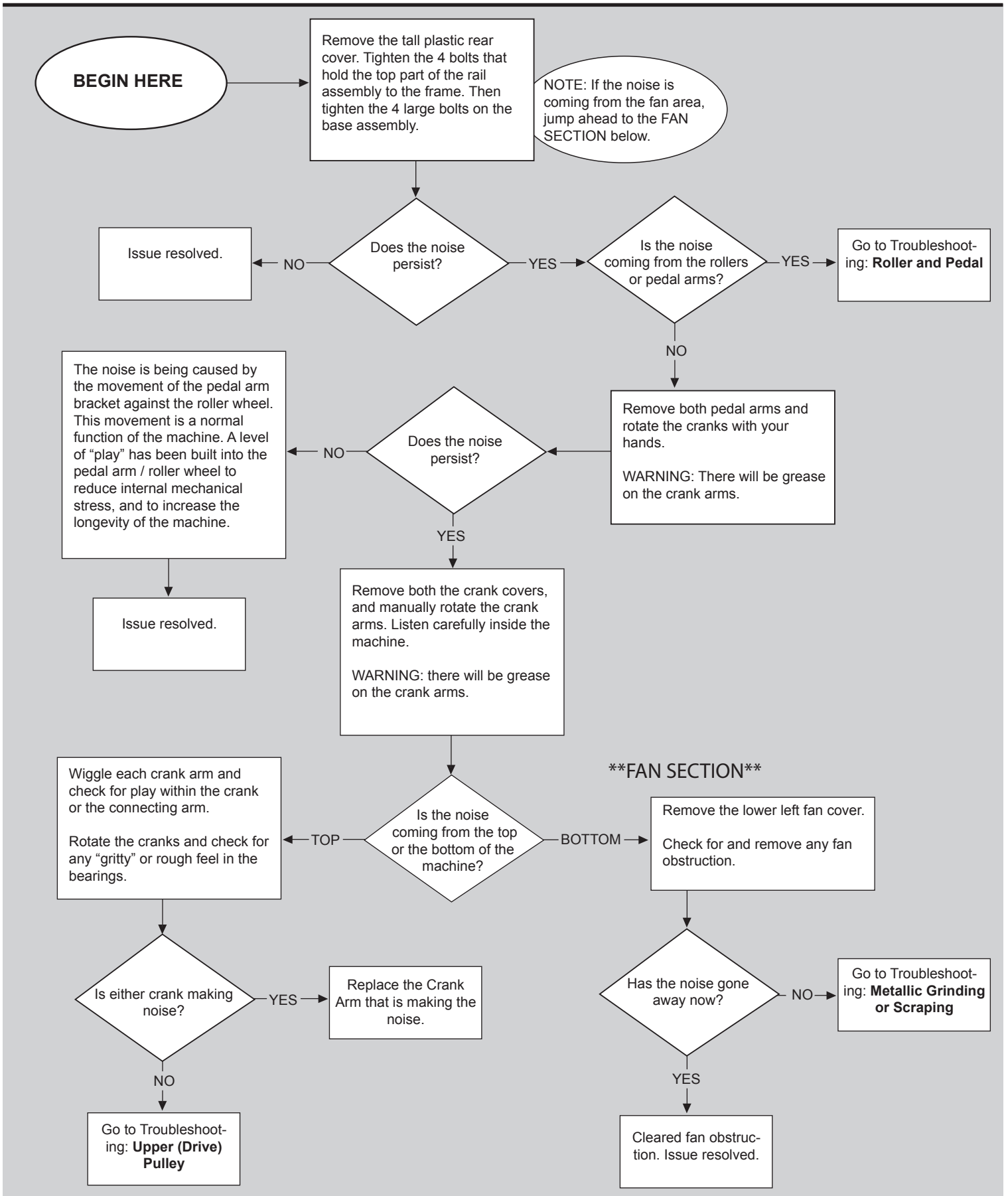

Noise Issues - Squeaking, Squealing or Chirping

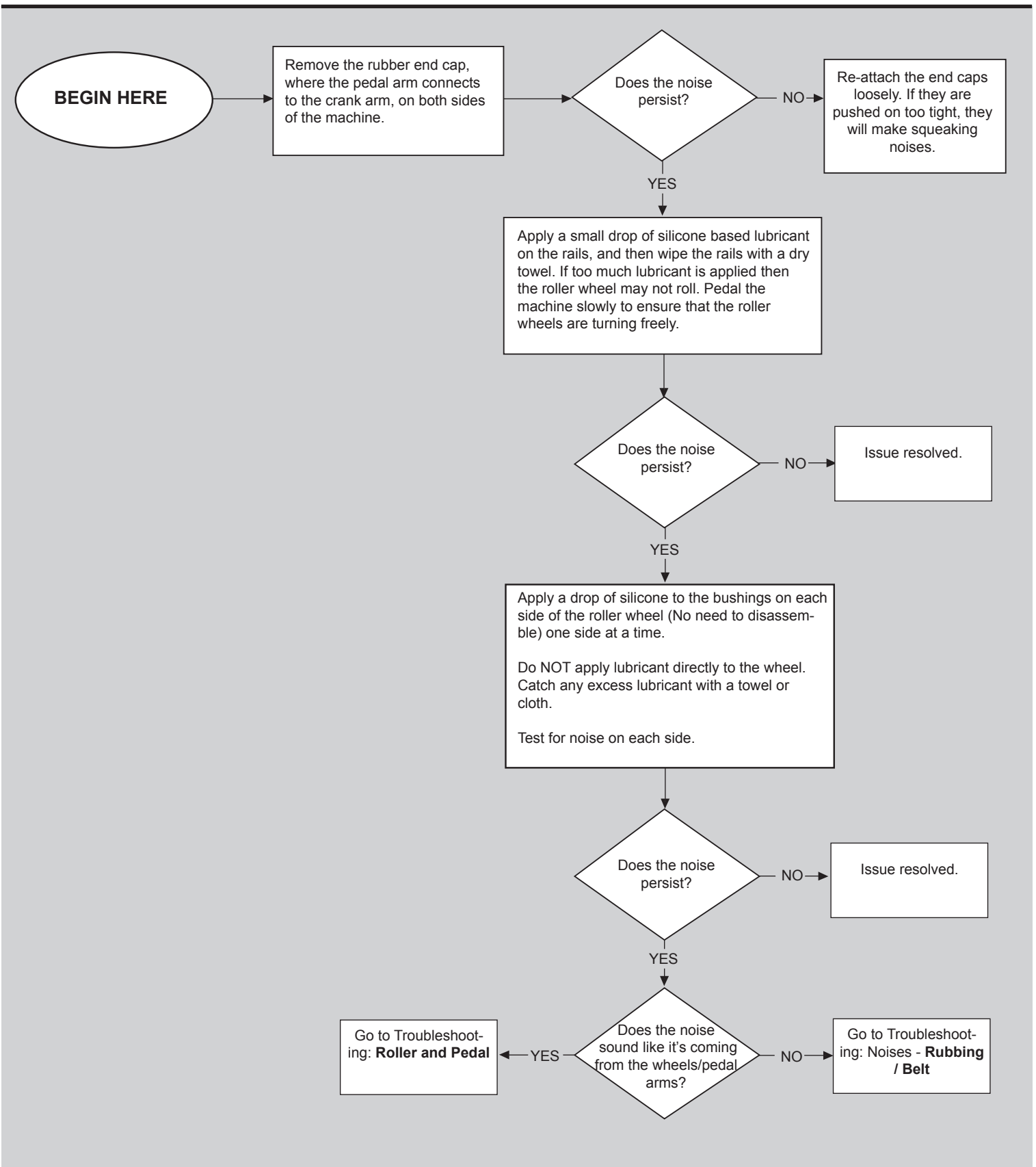

Contact Heart Rate Issues

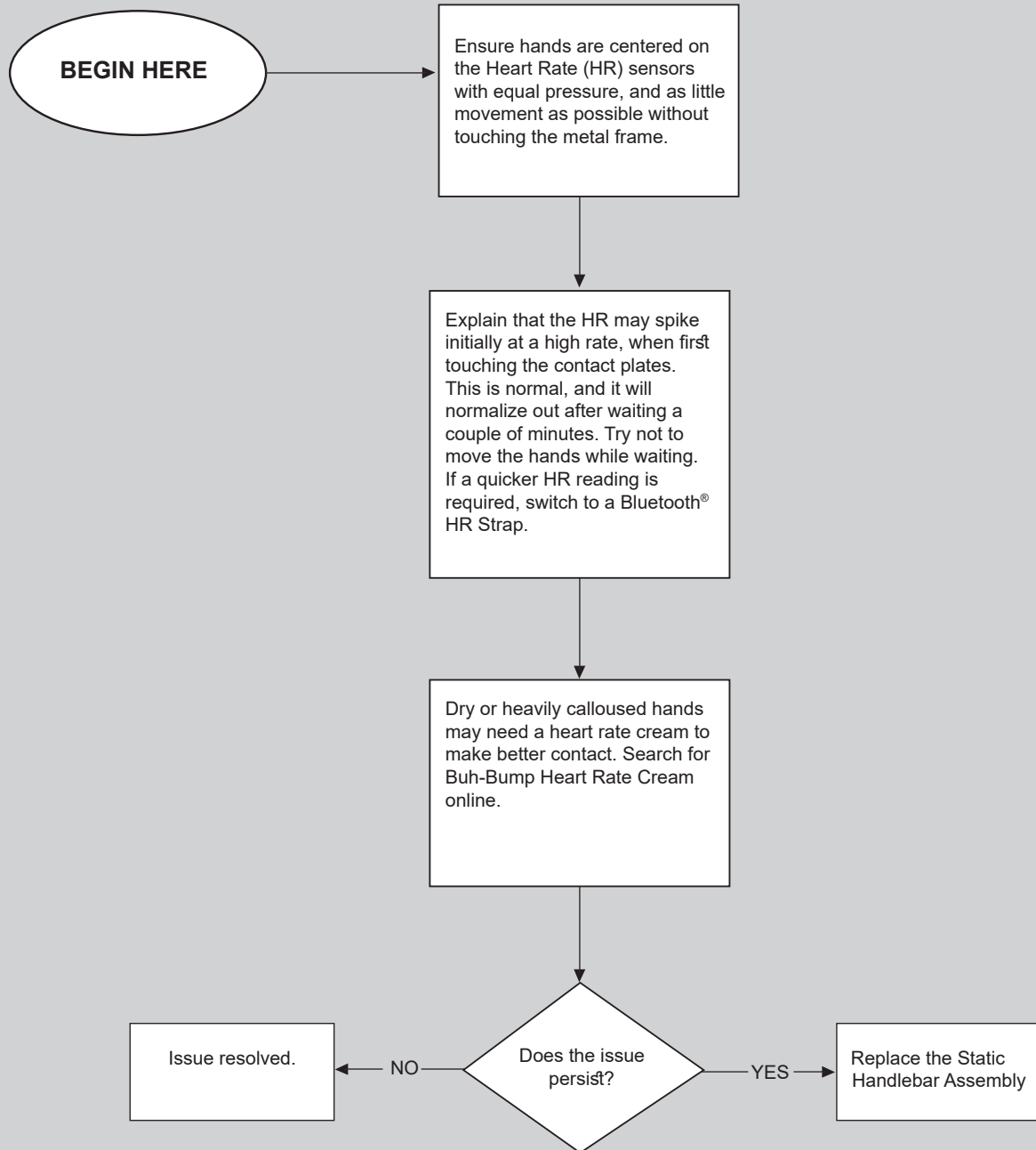

Bluetooth® Heart Rate Issues

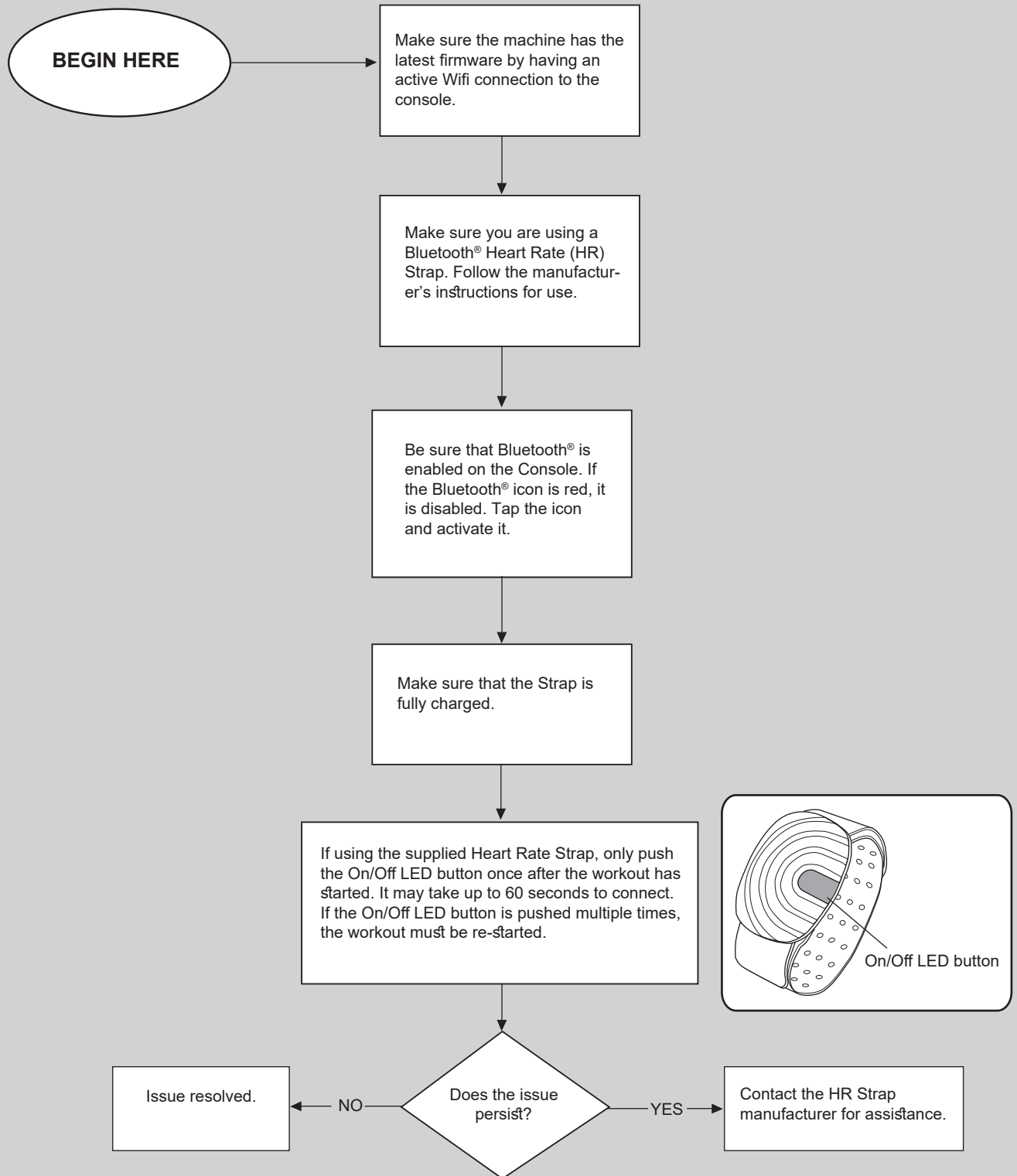

Upper (Drive) Pulley

Begin by inspecting around the machine for any hardware that may have fallen out of the machine.
Next remove the rear shroud, and inspect the upper, or drive, pulley. A flashlight may be needed.

Note the pulley screws, which can be seen protruding from the back of the pulley.
By manipulating the foot pedals the pulley will rotate, allowing the ability to check all four screws.

- * Note whether all four screws are in place.
- * Note whether all screws stick out about the same distance.
- * Check that the belt is in place, and is not visibly damaged.
- * Attempt to wiggle the pulley towards and away from the mast.
- * Observe whether the pulley wobbles as it rotates.

After inspection, proceed with the troubleshooting steps in order.

Crank Puller:
A Crank Puller is required to replace the drive pulley.

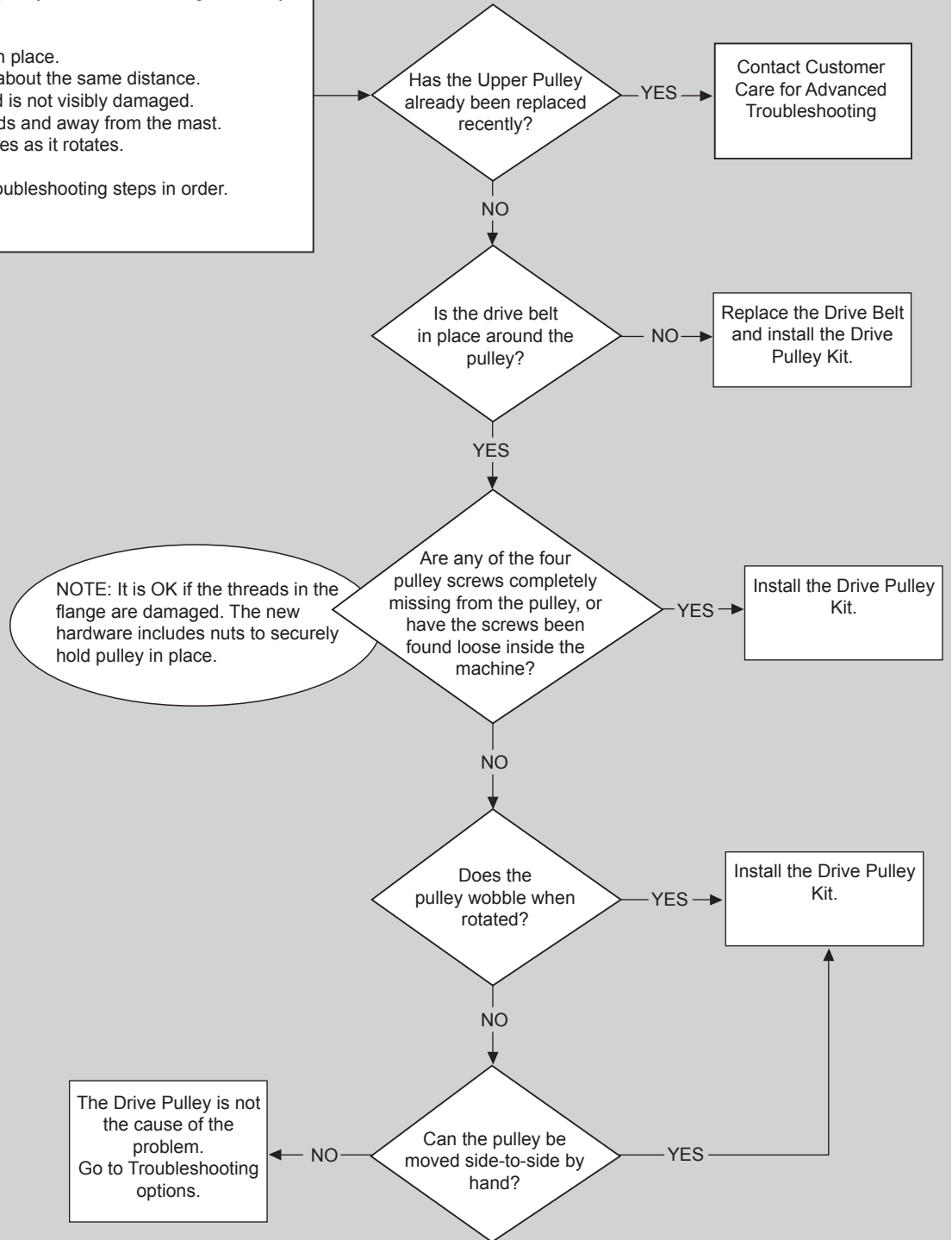

Restart the Machine

It may be necessary to restart your machine if there is a communication error or after an update. To restart the machine:

1. Unplug the power adapter from the machine and wall.
2. Push the On/Off (or outer) button on the back of the Console.

If nothing happens on the Console after the button is pushed, the Console Assembly may have been assembled too tight. The On/Off button may not be striking the switch. With a #2 Phillips screwdriver, slightly loosen the upper right screw (indicated by arrow) by a turn and a half. Push the On/Off button again.

3. On the Console screen, tap Power off.
4. The machine will de-activate. Allow the machine to sit without power for a few minutes.
5. Plug in the power adapter to the wall and the machine.
4. After a few moments, the machine will be fully activated from the restart.

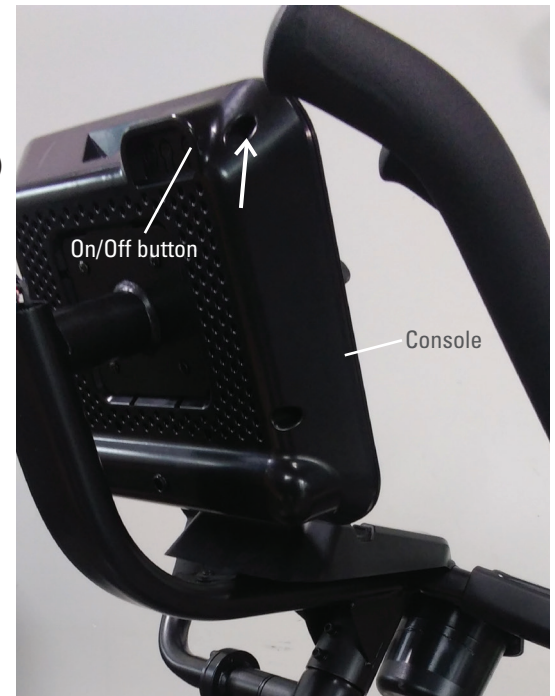

REPLACEMENT PROCEDURE SKILL LEVEL

- Level I : Low - very little mechanical knowledge or exposure.
Level II : Intermediate - some experience with mechanical procedures
Level III : Advanced - knowledgeable about mechanical procedures

! DANGER

To reduce the risk of electrical shock or unsupervised usage of the equipment, always unplug the power cord from the wall outlet before cleaning, maintaining or repairing this machine. Place the power cord in a secure location.

! When disposing of old parts, obey the applicable local and provincial requirements.

NOTICE: This document provides instructions for the adjustment of the Brake Assembly on the Bowflex™ Max Total™ machine / Max Total™ 16/40 / Max Trainer™ M9.

If you need assistance, please contact Customer Service (if purchased in US/Canada) or your local distributor (if purchased outside US/Canada). To find your local distributor, go to: www.nautilusinternational.com

 This icon means a potentially hazardous situation which, if not avoided, could result in death or serious injury. Read and understand all Warnings on this machine.

Nautilus, Inc., www.NautilusInc.com, 5415 Centerpoint Parkway, Groveport, OH 43125 U.S.A. - Customer Service: North America (800) 605-3369, csnls@nautilus.com | outside U.S. www.nautilusinternational.com | Printed in China | © 2019 Nautilus, Inc. | Bowflex, the B logo, Max Total, and Max Trainer are trademarks owned or licensed by Nautilus, Inc., registered or otherwise protected by common law in the United States and other nations. | **ORIGINAL DOCUMENT - ENGLISH VERSION ONLY**

Important Safety Instructions - Before servicing or using this equipment, obey the following warnings:

 This icon means a potentially hazardous situation which, if not avoided, could result in death or serious injury. Read and understand all Warnings on this machine.

- Read and understand the Part Replacement Procedure before working on the machine. Failure to obey the instructions and safety warnings could cause injury to the service technician or bystanders.
- Keep bystanders, children and pets away from the product being serviced at all times.
- Make sure that the repair is done in an appropriate work space away from foot traffic and exposure to bystanders.
- Disconnect all power and allow to sit for 5 minutes before you service this machine.
- Some components of the equipment can be heavy or awkward. Enlist the service of a second person when you do maintenance steps involving these components. Do not try to do heavy or awkward steps on your own.
- If replacement parts are necessary, use only genuine Nautilus replacement parts and hardware. Failure to use genuine replacement parts can cause a risk to users, keep the machine from operating correctly and will void the warranty.
- Be sure that all warning stickers and instructional placards applied to the product stay present and in good condition when doing maintenance or replacing components. If at any time the Warning labels become loose, unreadable or dislodged, replace the labels. If purchased in US/Canada, contact Customer Service for replacement labels. If purchased outside US/Canada, contact your local distributor for them.
- Do not try to change the design or functionality of the machine being serviced as this can adversely effect user safety and will void the warranty.
- Do not use the machine until all shrouds, instructions, warning labels and correct functionality have been verified and tested for correct performance.

• SAVE THESE INSTRUCTIONS.

Tools Required (not included)

#2 Phillips screwdriver

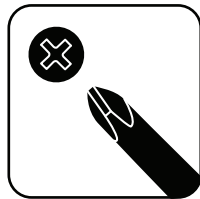

10mm hex wrench



8mm open ended wrench



Note: Your machine may not match the images provided exactly.

1. With power supplied to the machine, adjust the resistance to the maximum setting.
2. When the machine has completed the adjustments to the resistance, unplug the AC Adapter from the wall outlet and machine.
3. Remove the Right Stabilizer Shroud from the machine (if equipped).



4. Using a #2 Phillips screwdriver, remove the indicated (by ovals) screws and only loosen the lowest indicated screw (arrow) from the Right Fan Cover.

Note: Loosen the lowest screw by at least 3 full rotations.

5. The Right Fan Cover has a tab that needs to be pushed upward to clear the loosened screw. While pushing up on the tab, remove the Right Fan Cover from the assembly.

Note: The Power Cable is attached to the inside of the Right Fan Cover. Be sure not to crimp the cable by placing the Right Fan Cover close to the front of the machine.

To assist with assembly, note that the upper screw is a machine screw and not a self-tapping screw.

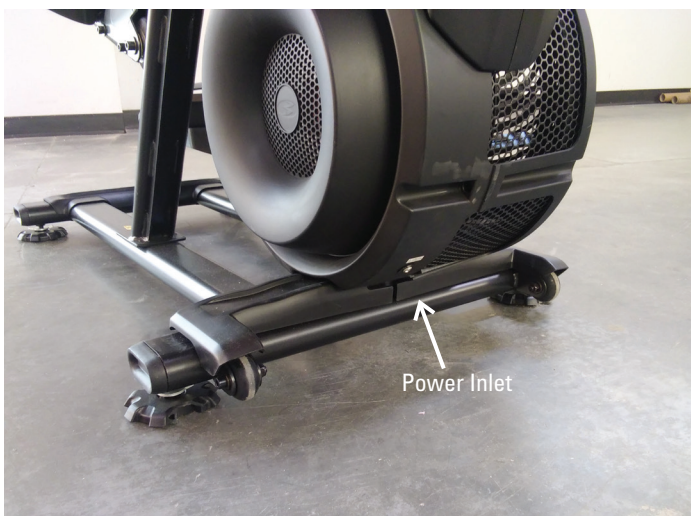
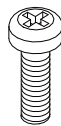

6. At the maximum resistance setting, the outer edge of the Brake Magnet should line up with the outer edge of the Brake Disc.

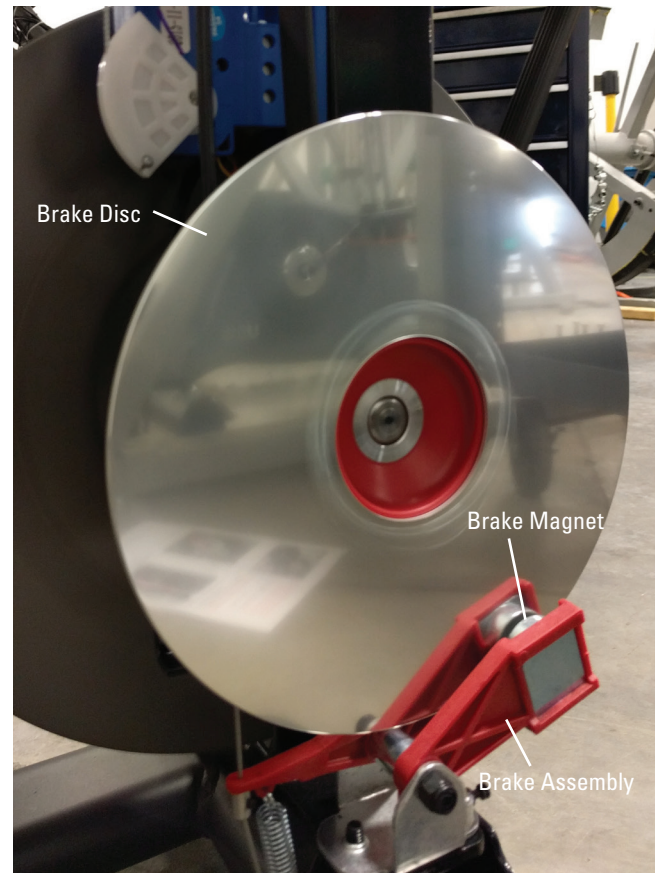
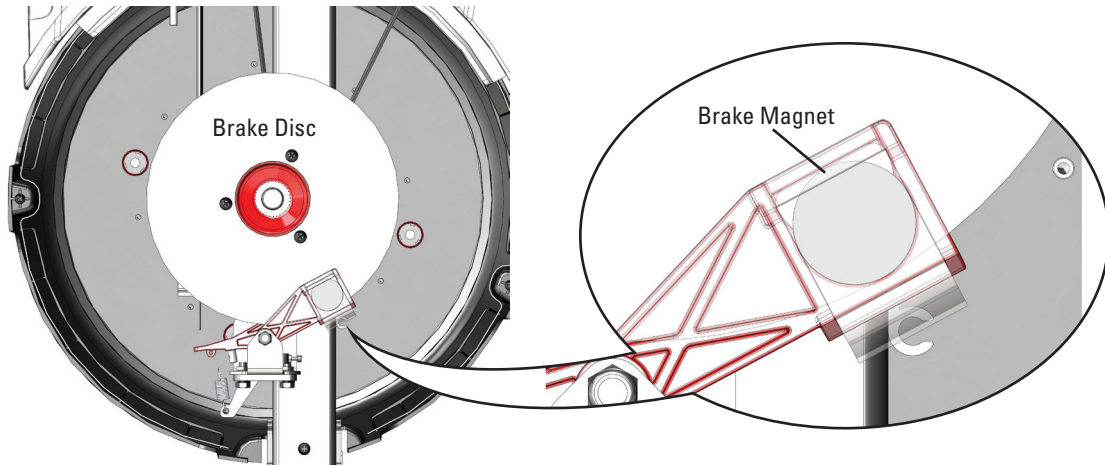

7. If the Brake Assembly needs to be adjusted, use a 8mm open ended wrench to loosen the Brake Cable Securing Nut. Turn the Adjustment Barrel by hand until the magnet is placed correctly.

8. Carefully rotate the Brake Disc. If the Brake Disc does not rub against the Brake Magnet, skip to step 11.

⚠ Keep fingers out of any pinch opportunities when rotating the Brake Disc.

Note: The Brake Disc may appear to have a slight “wobble”. This is normal and will not affect machine function.

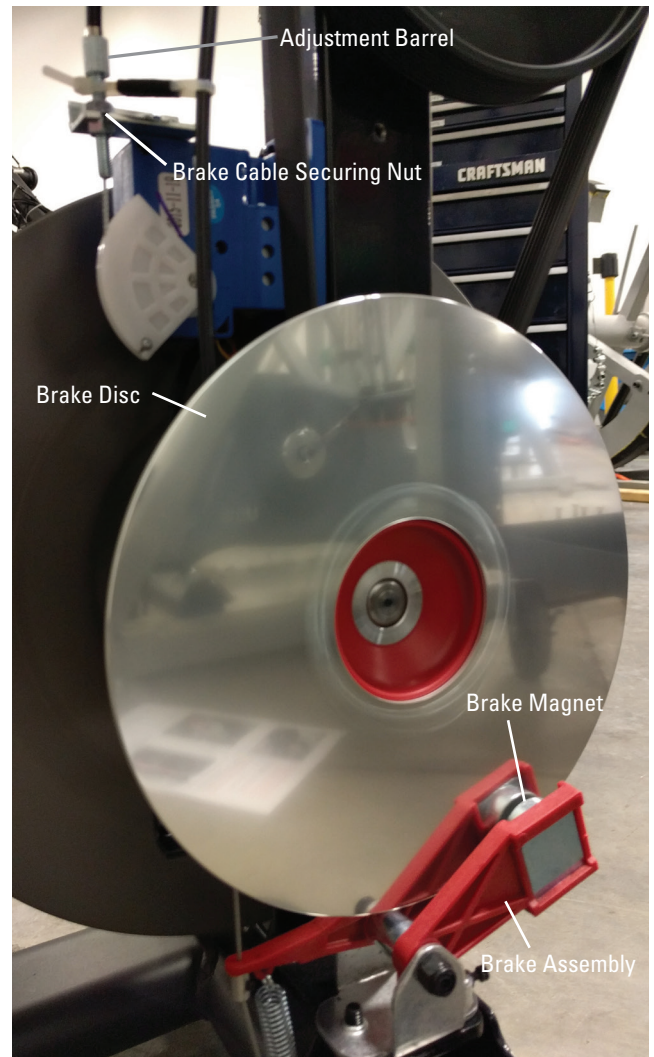

9. The Brake Magnets should be aligned with the Brake Disc and centered around the Brake Disc.

10. If the Brake Assembly only needs to be slightly adjusted, loosen the front screw (indicated by double-tailed arrow) that secures the Brake Assembly using a 10mm wrench. Rotate the Brake Assembly until the Magnets are aligned and of equal distance from the Brake Disc.

If the Brake Assembly must be fully shifted, loosen the 2 screws (indicated by arrows) that secure the assembly and shift it until centered and aligned with the Brake Disc. Fully tighten the hardware.

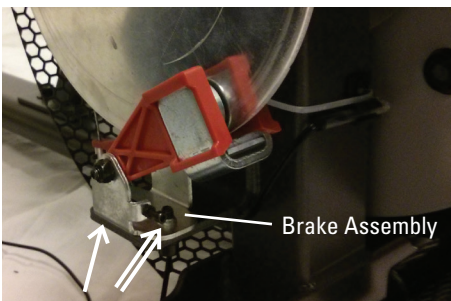

Rotate the Brake Disc to be sure it does not make contact with the magnets. If further adjustment is needed, repeat step 10.

⚠ Keep fingers out of any pinch opportunities when rotating the Brake Disc.

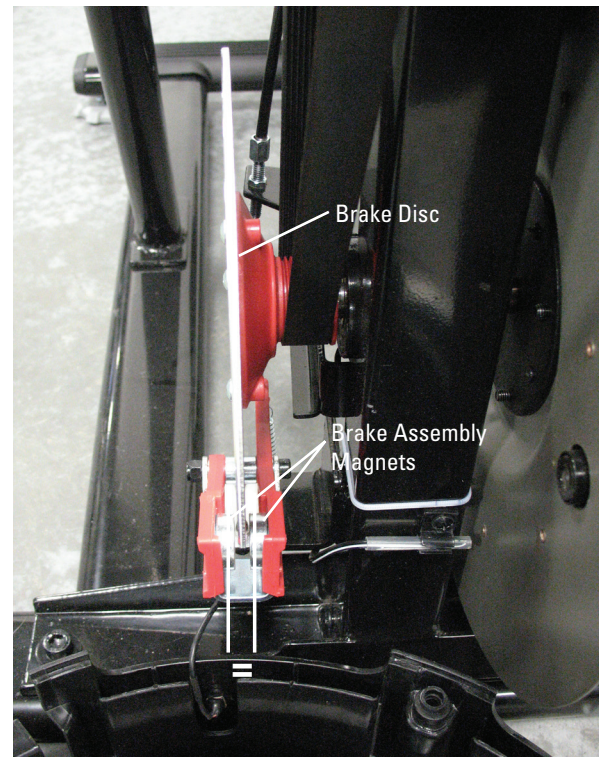

Note: The Brake Disc may appear to have a slight “wobble”. This is normal and will not affect machine function.

11. Installation is the reverse procedure.

12. Final Inspection

Inspect your machine to ensure that all hardware is tight and components are properly assembled.



Do not use until the machine has been fully assembled and inspected for correct performance in accordance with the Owner's Manual.

NOTICE: This document provides instructions for the adjustment of the Leg Assembly Alignment on the Bowflex™ Max Total™ machine / Max Total™ 16/40 / Max Trainer™ M9. The Rollers on the Leg Assemblies may be slightly “off”, or not fully centered onto the Rail Assembly. This procedure may assist with this condition.

If you need assistance, please contact Customer Service (if purchased in US/Canada) or your local distributor (if purchased outside US/Canada). To find your local distributor, go to: www.nautilusinternational.com

 **This icon means a potentially hazardous situation which, if not avoided, could result in death or serious injury. Read and understand all Warnings on this machine.**

Nautilus, Inc., www.NautilusInc.com, 5415 Centerpoint Parkway, Groveport, OH 43125 U.S.A. - Customer Service: North America (800) 605-3369, csnls@nautilus.com | outside U.S. www.nautilusinternational.com | Printed in China | © 2019 Nautilus, Inc. | Bowflex, the B logo, Max Total, and Max Trainer are trademarks owned or licensed by Nautilus, Inc., registered or otherwise protected by common law in the United States and other nations. |

ORIGINAL DOCUMENT - ENGLISH VERSION ONLY

Important Safety Instructions - Before servicing or using this equipment, obey the following warnings:

 **This icon means a potentially hazardous situation which, if not avoided, could result in death or serious injury. Read and understand all Warnings on this machine.**

- Read and understand the Part Replacement Procedure before working on the machine. Failure to obey the instructions and safety warnings could cause injury to the service technician or bystanders.
- Keep bystanders, children and pets away from the product being serviced at all times.
- Make sure that the repair is done in an appropriate work space away from foot traffic and exposure to bystanders.
- Disconnect all power and allow to sit for 5 minutes before you service this machine.
- Some components of the equipment can be heavy or awkward. Enlist the service of a second person when you do maintenance steps involving these components. Do not try to do heavy or awkward steps on your own.
- If replacement parts are necessary, use only genuine Nautilus replacement parts and hardware. Failure to use genuine replacement parts can cause a risk to users, keep the machine from operating correctly and will void the warranty.
- Be sure that all warning stickers and instructional placards applied to the product stay present and in good condition when doing maintenance or replacing components. If at any time the Warning labels become loose, unreadable or dislodged, replace the labels. If purchased in US/Canada, contact Customer Service for replacement labels. If purchased outside US/Canada, contact your local distributor for them.
- Do not try to change the design or functionality of the machine being serviced as this can adversely effect user safety and will void the warranty.
- Do not use the machine until all shrouds, instructions, warning labels and correct functionality have been verified and tested for correct performance.

• SAVE THESE INSTRUCTIONS.

Tools Required (not included)

#2 Phillips screwdriver

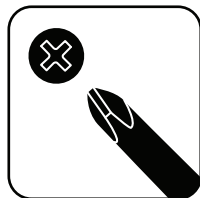

6mm hex wrench
8mm hex wrench



#2 standard screwdriver



If the Rollers seem to be “off” and not fully tracked on the Rail Assembly, this procedure may assist.

1. Unplug the AC Power Adapter from the machine.

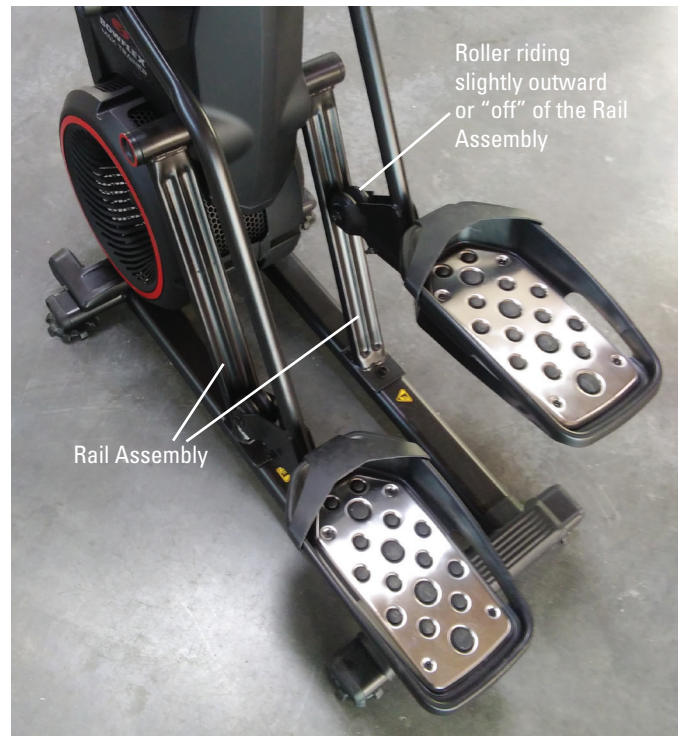

2. Using a #2 Phillips screwdriver, remove the 1 indicated screw from the Rear Shroud.

3. Carefully remove the Rear Shroud from the machine. Place a standard screwdriver behind and near the middle of the Rear Shroud and gently pry until it just releases. Then move the screwdriver to the bottom and gently pry until the Rear Shroud comes off.



4. Using a 6mm hex wrench, slightly loosen the indicated bolts that secure the Rail Assembly to the Frame Assembly.

 **Do not fully remove the hardware.**

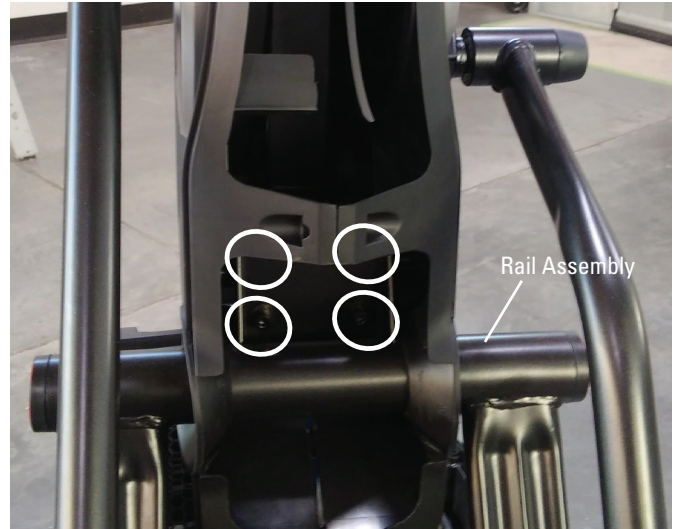

5. Using a 8mm hex wrench, slightly loosen the indicated bolts that secure the Rail Assembly to the Base Assembly.

 **Do not fully remove the hardware.**



6. Shift the Rail Assembly back and forth, or “wiggle”, until it seems to settle into the correct configuration. The Rollers will have adjusted with the Rail Assembly, and should be more “on” with the groove of the Roller centered onto the Rail Assembly.

7. Installation is the reverse procedure.

8. Final Inspection

Inspect your machine to ensure that all hardware is tight and components are properly assembled.

 **Do not use until the machine has been fully assembled and inspected for correct performance in accordance with the Owner’s Manual.**

NOTICE: This document provides instructions for advanced troubleshooting using a Digital Multimeter (DMM) on the Bowflex™ Max Total™ machine.

If you need assistance, please contact Customer Service (if purchased in US/Canada) or your local distributor (if purchased outside US/Canada). To find your local distributor, go to: www.nautilusinternational.com

This icon means a potentially hazardous situation which, if not avoided, could result in death or serious injury. Read and understand all Warnings on this machine.

Nautilus, Inc., www.NautilusInc.com, 5415 Centerpoint Parkway, Groveport, OH 43125 U.S.A. - Customer Service: North America (800) 605-3369, csnls@nautilus.com | outside U.S. www.nautilusinternational.com | Printed in China | © 2020 Nautilus, Inc. | Bowflex, the B logo, and Max Total are trademarks owned or licensed by Nautilus, Inc., registered or otherwise protected by common law in the United States and other nations. | **ORIGINAL DOCUMENT - ENGLISH VERSION ONLY**

Important Safety Instructions - Before servicing or using this equipment, obey the following warnings:

This icon means a potentially hazardous situation which, if not avoided, could result in death or serious injury. Read and understand all Warnings on this machine.

- Read and understand the Part Replacement Procedure before working on the machine. Failure to obey the instructions and safety warnings could cause injury to the service technician or bystanders.
- Keep bystanders, children and pets away from the product being serviced at all times.
- Make sure that the repair is done in an appropriate work space away from foot traffic and exposure to bystanders.
- Disconnect all power and allow to sit for 5 minutes before you service this machine.
- Some components of the equipment can be heavy or awkward. Enlist the service of a second person when you do maintenance steps involving these components. Do not try to do heavy or awkward steps on your own.
- If replacement parts are necessary, use only genuine Nautilus replacement parts and hardware. Failure to use genuine replacement parts can cause a risk to users, keep the machine from operating correctly and will void the warranty.
- Be sure that all warning stickers and instructional placards applied to the product stay present and in good condition when doing maintenance or replacing components. If at any time the Warning labels become loose, unreadable or dislodged, replace the labels. If purchased in US/Canada, contact Customer Service for replacement labels. If purchased outside US/Canada, contact your local distributor for them.
- Do not try to change the design or functionality of the machine being serviced as this can adversely effect user safety and will void the warranty.
- Do not use the machine until all shrouds, instructions, warning labels and correct functionality have been verified and tested for correct performance.

• SAVE THESE INSTRUCTIONS.

Tools Required (not included)

Digital Multimeter (DMM)

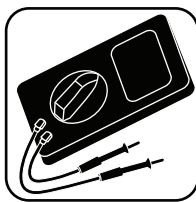

#2 Phillips screwdriver

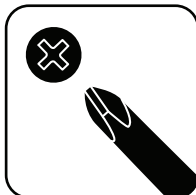

5mm hex wrench



Advanced Diagnostics

If a Digital Multimeter (DMM) is available then advanced troubleshooting can be performed for certain issues.

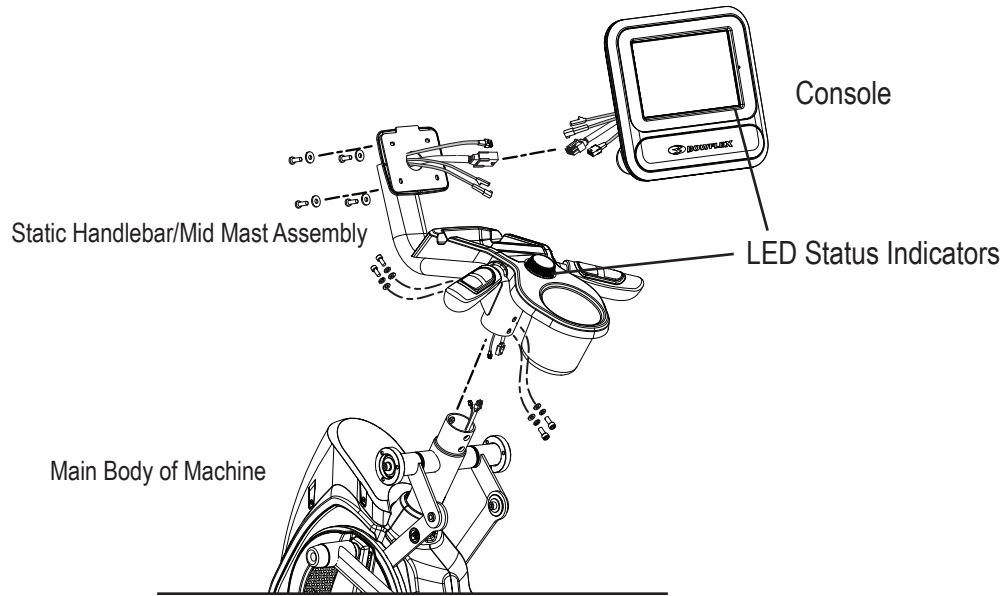

NO POWER/CONSOLE DOES NOT CHARGE

First check the status of LED power indicator.

- A. If lit steadily, then power supply is functioning and voltage is reaching the console. If console is not charging, then internal charging may need to be reset:
1. Disconnect power cord from base of machine. Wait 30 seconds.
 2. Re-connect power cord at base of machine. Console is now charging.
- B. If light is flashing slowly then quick charge mode is activated. Wait one hour for charging to complete. If flashing persists after one hour, then internal charging board may need to be reset:
1. Disconnect power cord from base of machine. Wait 30 seconds.
 2. Re-connect power cord at base of machine. Console is now charging.
- C. If light is flashing rapidly, then internal charging board must be reset:
1. Disconnect power cord from base of machine. Wait 30 seconds.
 2. Re-connect power cord at base of machine. Console is now charging.
- D. If not lit, then voltage is not reaching the console. Use the following multimeter tests to troubleshoot:
1. Check A/C Adapter.
 - a. Set DMM to measure DC voltage.
 - b. Check voltage output from the adapter.
 - Connect positive probe on inside of connector and negative probe on outside.
 - Voltage should be within 11-13VDC. If voltage is outside this range, replace adapter. If voltage is OK, continue to next test.

2. Check that voltage is reaching console.
 - a. Remove console and disconnect four wiring connections.
 - b. Locate 14 Pin Plug coming from Static Handlebar/Mid Mast Assembly.
 - c. Locate Purple and White Wires (see image).

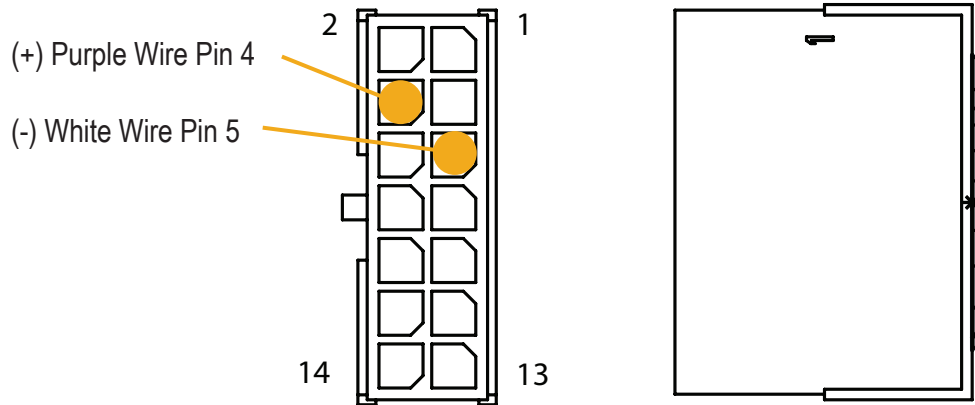

- d. Set DMM to measure DC voltage.
- e. Connect positive probe to Purple Wire Pin 4.
- f. Connect negative probe to White Wire Pin 5.
- g. Voltage should be within 11-13VDC.
 - If no voltage is present, there is a break in wiring within the machine. Proceed to next test.
 - If voltage is present, there is a break in the Wiring Harness within the console or it is not connected securely. Remove back of console to inspect and reseat wire, or replace if damaged.

- h. Check Lower Wiring Harness
 - Detach Static Handlebar/Mid Mast Assembly from main body of machine and disconnect two wiring connections.
 - Locate 14 pin plug coming from main body of machine.
 - Locate Purple and White Wires (see image).

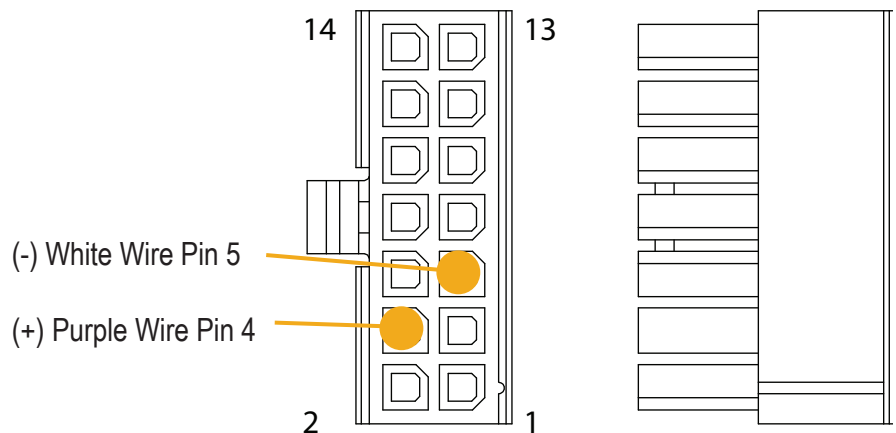

- Set DMM to measure DC voltage.
- Connect positive probe to Purple Wire Pin 4.
- Connect negative probe to White Wire Pin 5.
- Voltage should be within 11-13VDC.
 - If no voltage is present, there is a break in Lower Wire Harness or power plug. Inspect and replace as necessary.
 - If voltage is present but test at console failed, then fault is isolated to the Wiring Harness in the Static Handlebar/Mid Mast Assembly. Re-seat all connectors and re-check power to console (Step 2 above). If issue persists then replace the Wiring Harness in the Static Handlebar/Mid Mast Assembly, or Upper Wiring Harness.

WORKOUT PAUSES WHILE PEDALING/NEEDLE DOES NOT MOVE

If workout pauses while using the machine then console is not receiving a signal from the Speed Sensor. The sensor is a reed switch that closes each time one of four flywheel magnets passes by. If no signal is received at the console then this is usually caused by an interruption in the wiring (connector not secure or wire has been cut), misaligned sensor, or defective sensor. Use the following steps to test the wiring as the first troubleshooting step.

For these tests, set DMM to "Continuity" mode. This will typically have a symbol that looks like a sound wave and may be combined with a Diode symbol or Ohms symbol. Make sure DMM is turned on, and test by touching the probes together. Tester should emit a tone indicating continuity when the probes touch each other.



1. Disconnect power cord from machine and store in a safe place. Power is not required for these tests.
2. Check that signal is reaching the console. Remove console and disconnect four wiring connections. Set console carefully aside.
 - A. Locate 14 Pin Plug coming from Static Handlebar/Mid Mast Assembly.
 - B. Locate Red and Black Wires (see image).
 - C. Verify DMM is set to measure continuity.
 - D. Connect one probe to Red Wire Pin 12.
 - E. Connect the other probe to Black Wire Pin 10.

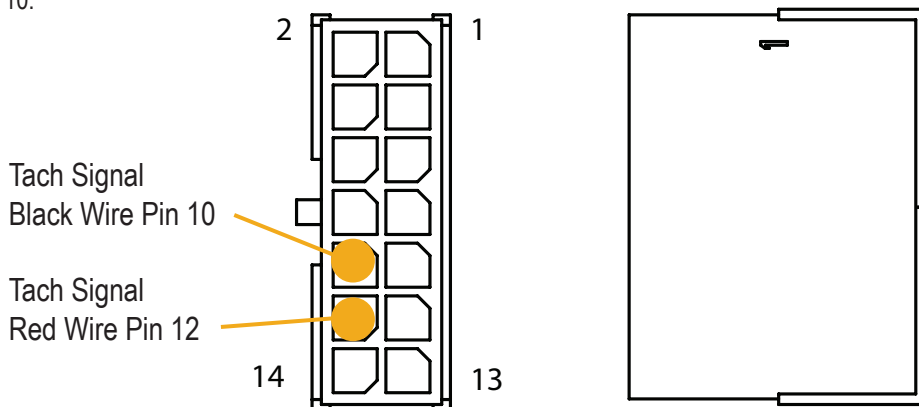

- a. If no beep is heard then the signal is interrupted within a Wiring Harness. Proceed to next test.
 - b. If beep is heard then connector was not secure or there is a break in the Upper Wiring Harness within the console housing. Remove back of console to inspect and reseal wire, or replace if damaged.
3. Check that signal is present at Lower Wiring Harness exiting main body of machine.
 - A. Detach Static Handlebar/Mid Mast Assembly from main body of machine and disconnect two wiring connections.
 - B. Locate 14 Pin Plug coming from main body of machine.
 - C. Locate Red and Black Wires (see image).
 - D. Verify DMM is set to measure continuity.
 - E. Connect one probe to Red Wire Pin 12.
 - F. Connect the other probe to Black Wire Pin 10.

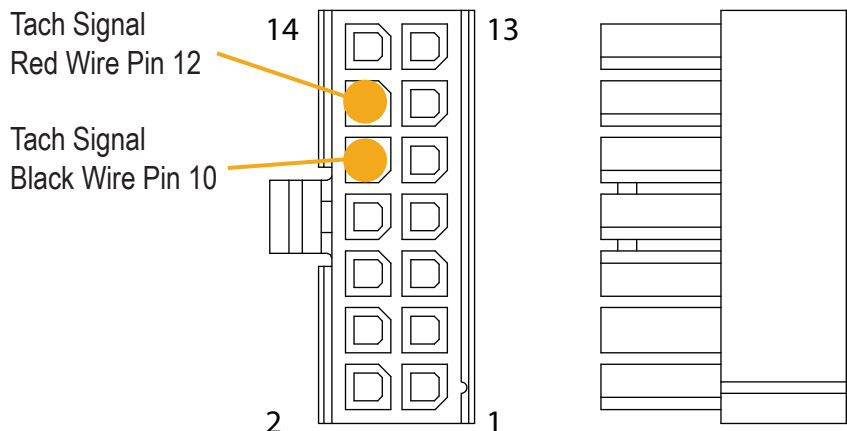

- G. Operate pedals of machine. Continuity tester should beep rapidly as the internal flywheel spins.
- a. If no beep is heard then the Speed Sensor is misaligned, disconnected, or defective. Follow the “Needle will not Move or Machine Goes to Sleep While in Use” Troubleshooting Steps in the main Troubleshooting section of the Service Manual to access and inspect/adjust sensor.
 - b. If beep is heard but previous test at console connection failed, then the connection is interrupted in the Static Handlebar/Mid Mast Assembly. Replace the Upper Wiring Harness in the Static Handlebar/Mid Mast Assembly.
 - c. Re-seat all connectors and re-check signal to console (Step 2 above).

NOTICE: This document provides instructions to modify the Resistance Knob Cable on the Bowflex™ Max Total™ machine / Max Total™ 16/40 / Max Trainer™ M9.

Note: Only perform this procedure if directly instructed to do it by Customer Service or your local distributor.

If you need assistance, please contact Customer Service (if purchased in US/Canada) or your local distributor (if purchased outside US/Canada). To find your local distributor, go to: www.nautilusinternational.com

 **This icon means a potentially hazardous situation which, if not avoided, could result in death or serious injury. Read and understand all Warnings on this machine.**

Nautilus, Inc., www.NautilusInc.com, 5415 Centerpoint Parkway, Groveport, OH 43125 U.S.A. - Customer Service: North America (800) 605-3369, csnls@nautilus.com | outside U.S. www.nautilusinternational.com | Printed in China | © 2020 Nautilus, Inc. | Bowflex, the B logo, Max Total, and Max Trainer are trademarks owned or licensed by Nautilus, Inc., registered or otherwise protected by common law in the United States and other nations. | ORIGINAL DOCUMENT - ENGLISH VERSION ONLY

Important Safety Instructions - Before servicing or using this equipment, obey the following warnings:

 **This icon means a potentially hazardous situation which, if not avoided, could result in death or serious injury. Read and understand all Warnings on this machine.**

- Read and understand the Part Replacement Procedure before working on the machine. Failure to obey the instructions and safety warnings could cause injury to the service technician or bystanders.
- Keep bystanders, children and pets away from the product being serviced at all times.
- Make sure that the repair is done in an appropriate work space away from foot traffic and exposure to bystanders.
- Disconnect all power and allow to sit for 5 minutes before you service this machine.
- Some components of the equipment can be heavy or awkward. Enlist the service of a second person when you do maintenance steps involving these components. Do not try to do heavy or awkward steps on your own.
- If replacement parts are necessary, use only genuine Nautilus replacement parts and hardware. Failure to use genuine replacement parts can cause a risk to users, keep the machine from operating correctly and will void the warranty.
- Be sure that all warning stickers and instructional placards applied to the product stay present and in good condition when doing maintenance or replacing components. If at any time the Warning labels become loose, unreadable or dislodged, replace the labels. If purchased in US/Canada, contact Customer Service for replacement labels. If purchased outside US/Canada, contact your local distributor for them.
- Do not try to change the design or functionality of the machine being serviced as this can adversely effect user safety and will void the warranty.
- Do not use the machine until all shrouds, instructions, warning labels and correct functionality have been verified and tested for correct performance.

• SAVE THESE INSTRUCTIONS.

Tools Required (not included)

#2 Phillips screwdriver

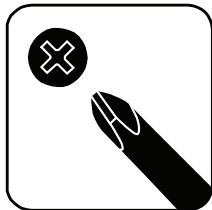

Scissors or Cable Cutters



Note: Your machine may not match the images provided exactly.

1. Unplug the AC Adapter from the wall outlet and machine.

2. Remove the Rear Console Cover from the Console Assembly.

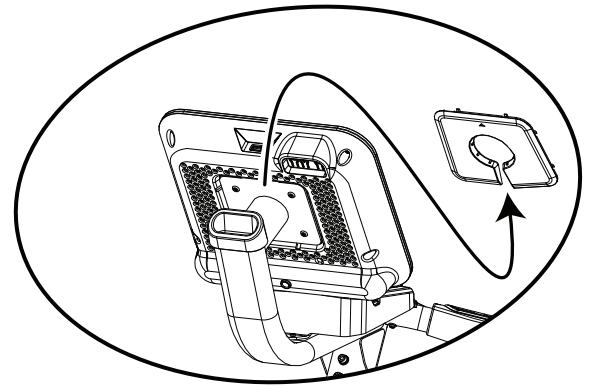

3. Using a #2 Phillips screwdriver, remove the screws (indicated by ovals) from the Console Assembly.

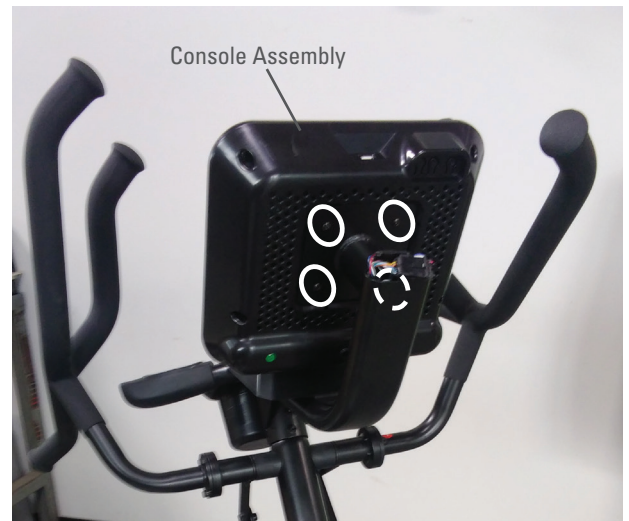

4. Carefully tilt the Console Assembly off of the Static Handlebar and expose the Cable Connections.

Note: Do not crimp any of the Console Cables. This step may require two people.

5. Carefully disconnect the Cables and place the Console outside the work area.

Note: Do not crimp any of the Console Cables.

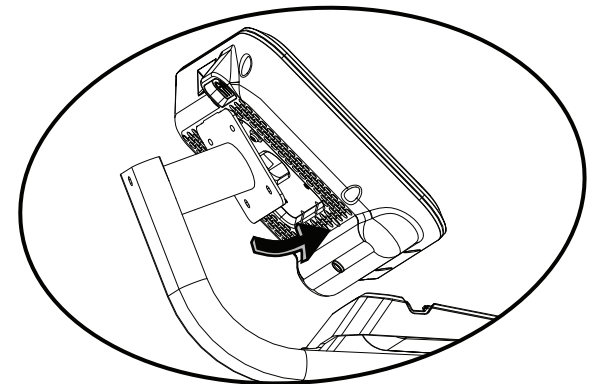

6. Locate the Resistance Knob Cable which has the 5-pin Wire Connector coming from the Console Mast. This Cable will have Red, Yellow, Black, Green and White Wires inside of it.



7. Slightly pull out the White Wire from the others and cut it twice with scissors or wire cutters. The first cut should be as near the 5-pin Wire Connector as possible, and the second cut should be where the Cable Sleeve covers all the Wires.

Note: Be sure not to cut or crimp any of the other Wires.

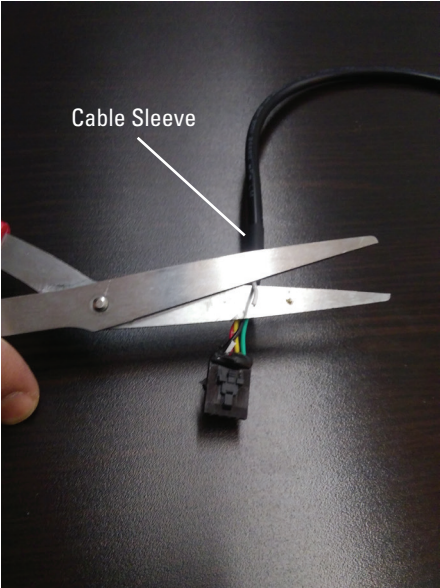
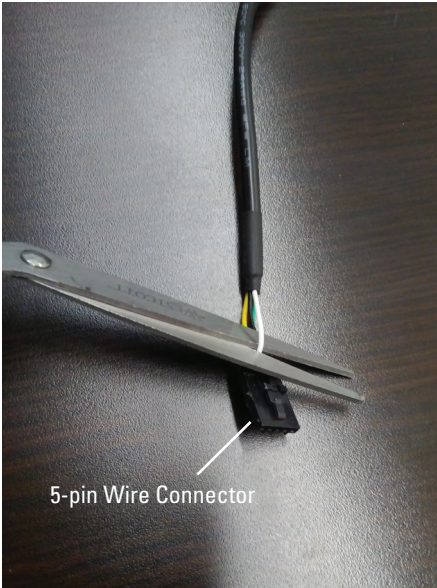
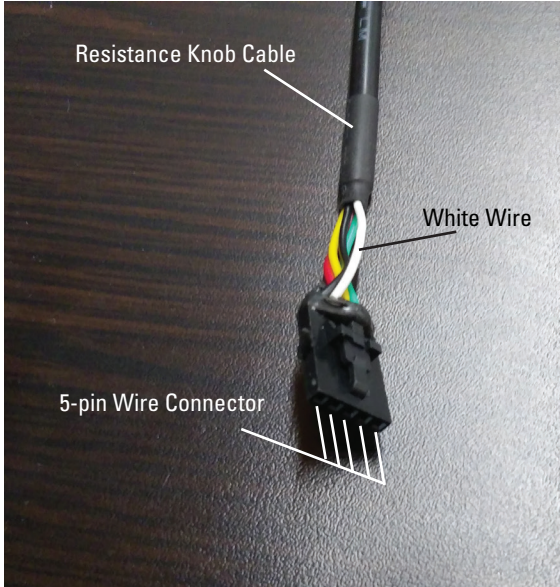

8. Dispose of the removed piece of White Wire.

9. Re-assemble the machine in the reverse order of when the parts were removed.

Note: Do not cut or crimp the Cables. Each Cable connector (3-pin, 4-pin, 5-pin and 14-pin) has a corresponding end connector with that many openings. Be sure to fully connect the cable connectors. When attaching the Console Assembly, do not fully tighten the hardware until all hardware has been hand tightened.

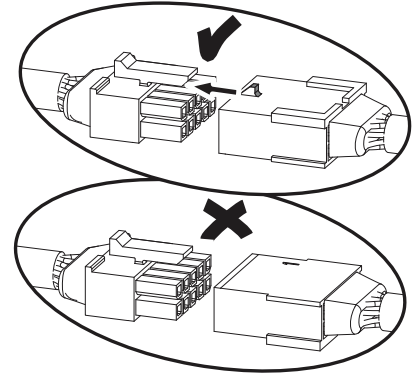

10. Final Inspection

Inspect your machine to ensure that all hardware is tight and components are properly assembled.



Do not use until the machine has been fully assembled and inspected for correct performance in accordance with the Owner's Manual.

NOTICE: This document provides instructions for the replacement of the Brake Assembly on the Bowflex™ Max Total™ machine / Max Total™ 16/40 / Max Trainer™ M9.

If you need assistance, please contact Customer Service (if purchased in US/Canada) or your local distributor (if purchased outside US/Canada). To find your local distributor, go to: www.nautilusinternational.com

 This icon means a potentially hazardous situation which, if not avoided, could result in death or serious injury. Read and understand all Warnings on this machine.

Nautilus, Inc., www.NautilusInc.com, 5415 Centerpoint Parkway, Groveport, OH 43125 U.S.A. - Customer Service: North America (800) 605-3369, csnls@nautilus.com | outside U.S. www.nautilusinternational.com | Printed in China | © 2019 Nautilus, Inc. | Bowflex, the B logo, Max Total, and Max Trainer are trademarks owned or licensed by Nautilus, Inc., registered or otherwise protected by common law in the United States and other nations. | **ORIGINAL DOCUMENT - ENGLISH VERSION ONLY**

Important Safety Instructions - Before servicing or using this equipment, obey the following warnings:

 This icon means a potentially hazardous situation which, if not avoided, could result in death or serious injury. Read and understand all Warnings on this machine.

- Read and understand the Part Replacement Procedure before working on the machine. Failure to obey the instructions and safety warnings could cause injury to the service technician or bystanders.
- Keep bystanders, children and pets away from the product being serviced at all times.
- Make sure that the repair is done in an appropriate work space away from foot traffic and exposure to bystanders.
- Disconnect all power and allow to sit for 5 minutes before you service this machine.
- Some components of the equipment can be heavy or awkward. Enlist the service of a second person when you do maintenance steps involving these components. Do not try to do heavy or awkward steps on your own.
- If replacement parts are necessary, use only genuine Nautilus replacement parts and hardware. Failure to use genuine replacement parts can cause a risk to users, keep the machine from operating correctly and will void the warranty.
- Be sure that all warning stickers and instructional placards applied to the product stay present and in good condition when doing maintenance or replacing components. If at any time the Warning labels become loose, unreadable or dislodged, replace the labels. If purchased in US/Canada, contact Customer Service for replacement labels. If purchased outside US/Canada, contact your local distributor for them.
- Do not try to change the design or functionality of the machine being serviced as this can adversely effect user safety and will void the warranty.
- Do not use the machine until all shrouds, instructions, warning labels and correct functionality have been verified and tested for correct performance.

• SAVE THESE INSTRUCTIONS.

Tools Required (not included)

#2 Phillips screwdriver

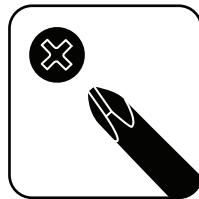

8mm wrench
10mm wrench

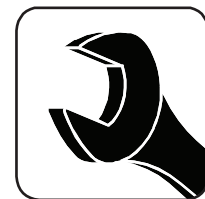

2.5mm hex wrench



Tape, any type (only used as a place holder)



Note: Your machine may not match the images provided exactly.

1. With power supplied to the machine, adjust the resistance to the maximum setting.
2. Unplug the AC Adapter from the wall outlet and machine.
3. Remove the Right Stabilizer Shroud from the machine.



4. Using a #2 Phillips screwdriver, remove the indicated (by ovals) screws and only loosen the lowest indicated screw (arrow) from the Right Fan Cover.

Note: Loosen the lowest screw by at least 3 full rotations.

5. The Right Fan Cover has a tab that needs to be pushed upward to clear the loosened screw. While pushing up on the tab, remove the Right Fan Cover from the assembly.

Note: The Power Cable is attached to the inside of the Right Fan Cover. Be sure not to crimp the cable by placing the Right Fan Cover close to the front of the machine.

To assist with assembly, note that the upper screw is a machine screw and not a self-tapping screw.

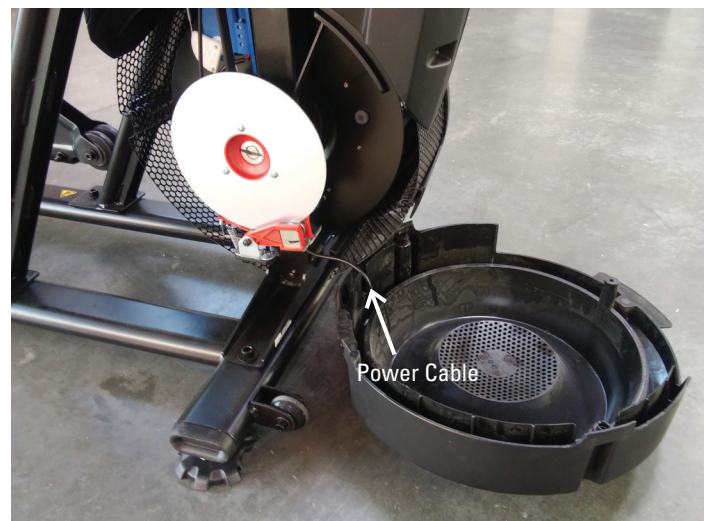
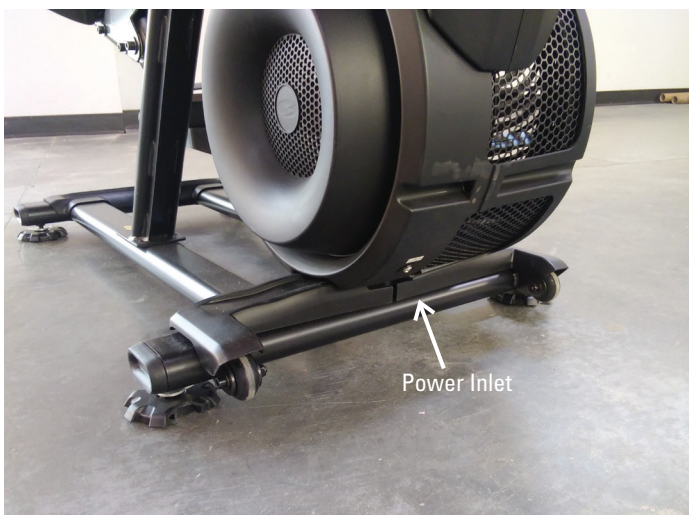
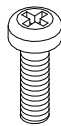

6. Using a #2 Phillips screwdriver, remove the 3 indicated screws from the Brake Disc.

7. Carefully remove the Brake Disc from the machine.

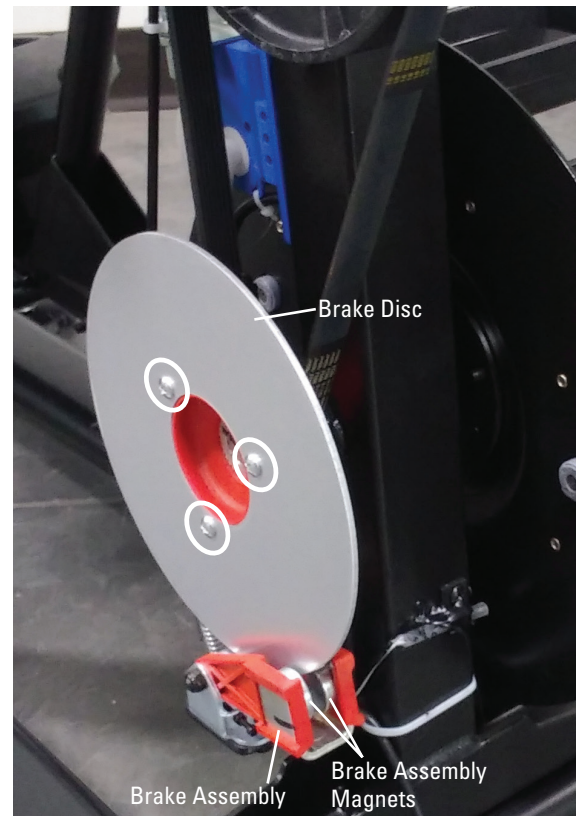

8. Place a piece of tape (as a marker) on the Brake Cable immediately above the Brake Arm. During re-assembly, the tape will be a guide for the placement of the new Brake Arm on the Brake Cable.

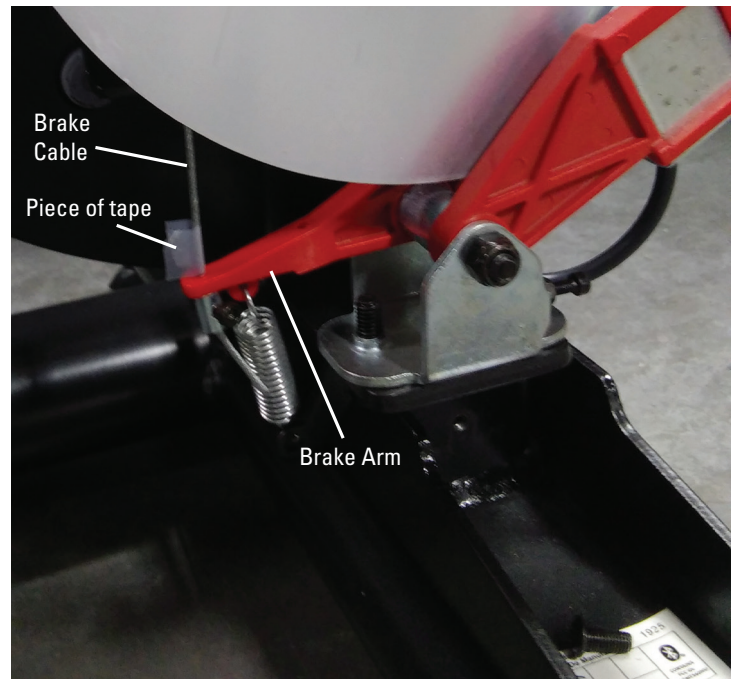

9. While applying upward pressure to the Brake Arm, remove the hardware that secures the Brake Cable to the Brake Arm with a 2.5mm hex wrench. Once loose, gradually lower the Brake Arm.

Note: Be aware that the Spring will pull the Brake Arm once released. An object can be placed under the Brake Arm to supply resistance during the release of the Brake Cable Hardware.

10. Remove the Brake Spring from the Brake Arm.

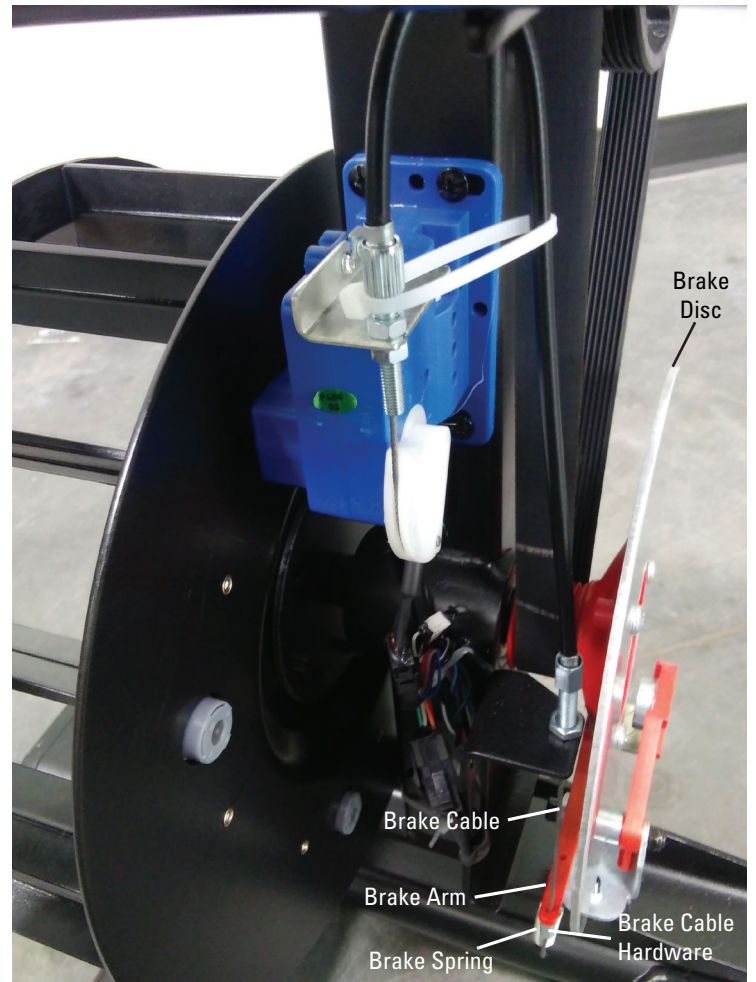

11. Using a 10mm open-end wrench, remove the screws that connect the Brake Assembly and remove it.

12. Attach the new Brake Assembly, but do not fully tighten the hardware.

13. Attach the Brake Disc.

14. Reattach the Brake Spring and the Brake Cable to the Brake Arm, and adjust to the tape marker. Tighten the hardware that attaches to the Brake Cable to 2.6-3.0 Nm torque.

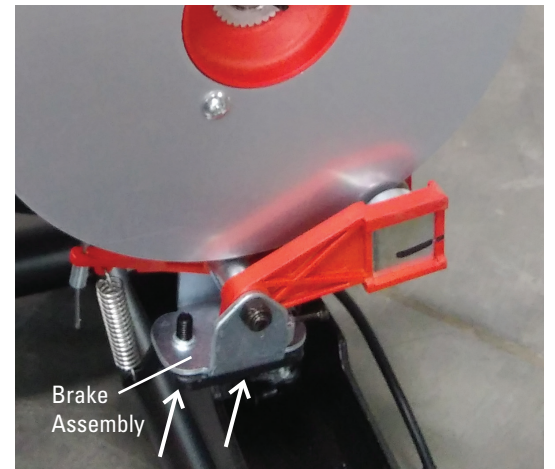

15. At the maximum resistance setting, the outer edge of the Brake Magnet should line up with the outer edge of the Brake Disc.

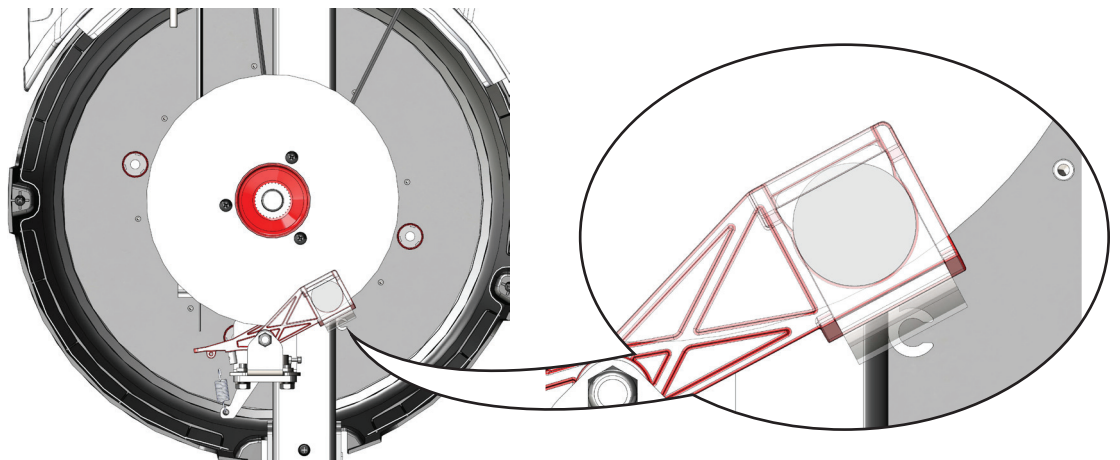

16. If the Brake Assembly needs to be adjusted, use a 8mm open ended wrench to loosen the Brake Cable Securing Nut. Turn the Adjustment Barrel by hand until the magnet is placed correctly.

17. Carefully rotate the Brake Disc. If the Brake Disc does not rub against the Brake Magnet, skip to step 20.

⚠ Keep fingers out of any pinch opportunities when rotating the Brake Disc.

Note: The Brake Disc may appear to have a slight “wobble”. This is normal and will not affect machine function.

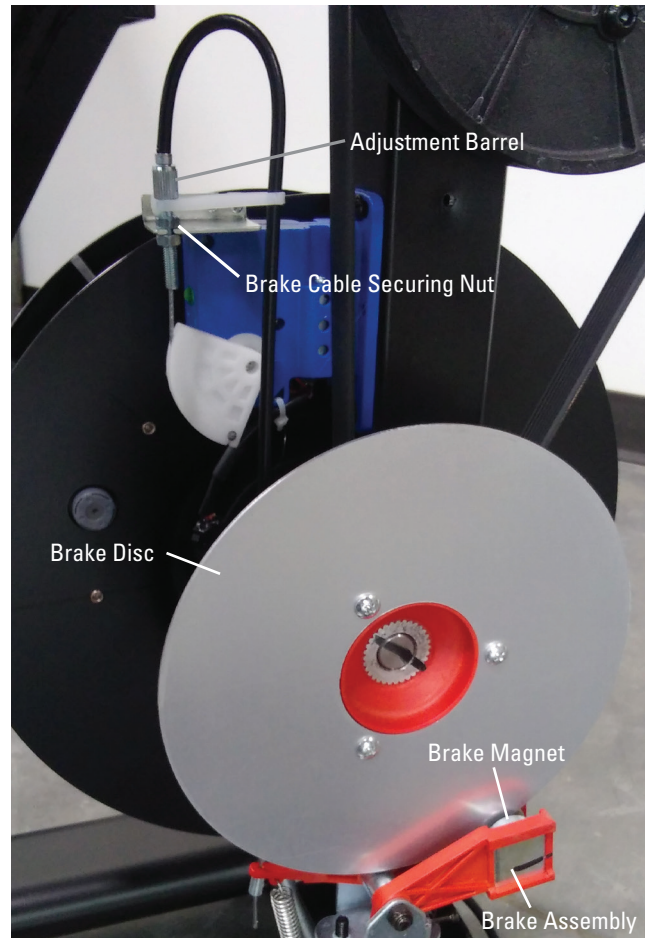

18. The Brake Magnets should be aligned with the Brake Disc and centered around the Brake Disc.

19. If the Brake Assembly only needs to be slightly adjusted, loosen the front screw (indicated by double-tailed arrow) that secures the Brake Assembly using a 10mm open-end wrench. Rotate the Brake Assembly until the Magnets are aligned and of equal distance from the Brake Disc.

If the Brake Assembly must be fully shifted, loosen the 2 screws that secure the assembly and shift it until centered and aligned with the Brake Disc. Fully tighten the hardware.

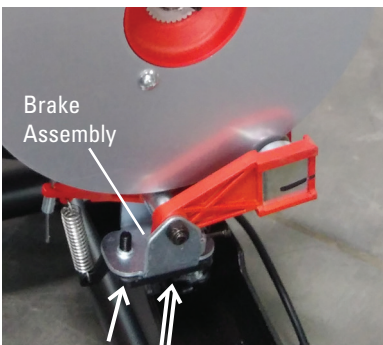

Rotate the Brake Disc to be sure it does not make contact with the magnets. If further adjustment is needed, repeat step 20.

⚠ Keep fingers out of any pinch opportunities when rotating the Brake Disc.

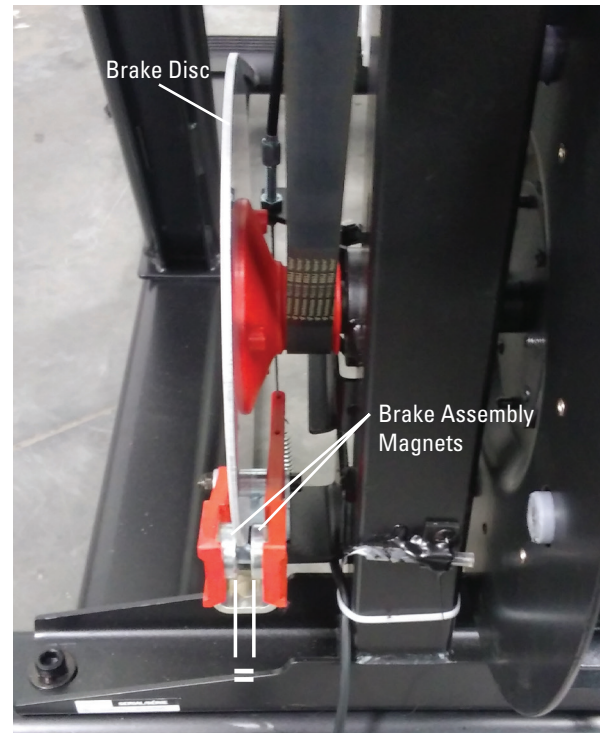

Note: The Brake Disc may appear to have a slight “wobble”. This is normal and will not affect machine function.

20. Installation is the reverse procedure.

21. Final Inspection

Inspect your machine to ensure that all hardware is tight and components are properly assembled.



Do not use until the machine has been fully assembled and inspected for correct performance in accordance with the Owner's Manual.

NOTICE: This document provides instructions for the replacement of the Console Assembly on the Bowflex™ Max Total™ machine / Max Total™ 16/40 / Max Trainer™ M9.

If you need assistance, please contact Customer Service (if purchased in US/Canada) or your local distributor (if purchased outside US/Canada). To find your local distributor, go to: www.nautilusinternational.com

 This icon means a potentially hazardous situation which, if not avoided, could result in death or serious injury. Read and understand all Warnings on this machine.

Nautilus, Inc., www.NautilusInc.com, 5415 Centerpoint Parkway, Groveport, OH 43125 U.S.A. - Customer Service: North America (800) 605-3369, csnls@nautilus.com | outside U.S. www.nautilusinternational.com | Printed in China | © 2019 Nautilus, Inc. | Bowflex, the B logo, Max Total, and Max Trainer are trademarks owned or licensed by Nautilus, Inc., registered or otherwise protected by common law in the United States and other nations. | **ORIGINAL DOCUMENT - ENGLISH VERSION ONLY**

Important Safety Instructions - Before servicing or using this equipment, obey the following warnings:

 This icon means a potentially hazardous situation which, if not avoided, could result in death or serious injury. Read and understand all Warnings on this machine.

- Read and understand the Part Replacement Procedure before working on the machine. Failure to obey the instructions and safety warnings could cause injury to the service technician or bystanders.
- Keep bystanders, children and pets away from the product being serviced at all times.
- Make sure that the repair is done in an appropriate work space away from foot traffic and exposure to bystanders.
- Disconnect all power and allow to sit for 5 minutes before you service this machine.
- Some components of the equipment can be heavy or awkward. Enlist the service of a second person when you do maintenance steps involving these components. Do not try to do heavy or awkward steps on your own.
- If replacement parts are necessary, use only genuine Nautilus replacement parts and hardware. Failure to use genuine replacement parts can cause a risk to users, keep the machine from operating correctly and will void the warranty.
- Be sure that all warning stickers and instructional placards applied to the product stay present and in good condition when doing maintenance or replacing components. If at any time the Warning labels become loose, unreadable or dislodged, replace the labels. If purchased in US/Canada, contact Customer Service for replacement labels. If purchased outside US/Canada, contact your local distributor for them.
- Do not try to change the design or functionality of the machine being serviced as this can adversely effect user safety and will void the warranty.
- Do not use the machine until all shrouds, instructions, warning labels and correct functionality have been verified and tested for correct performance.

• SAVE THESE INSTRUCTIONS.

Tools Required (not included)

#2 Phillips screwdriver

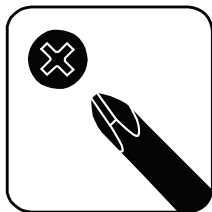

Note: Your machine may not match the images provided exactly.

1. Unplug the AC Adapter from the wall outlet and machine.

2. Remove the Rear Console Cover from the Console Assembly.

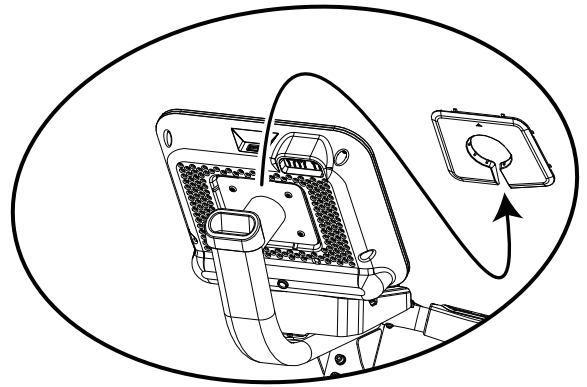

3. Using a #2 Phillips screwdriver, remove the screws (indicated by ovals) from the Console Assembly.

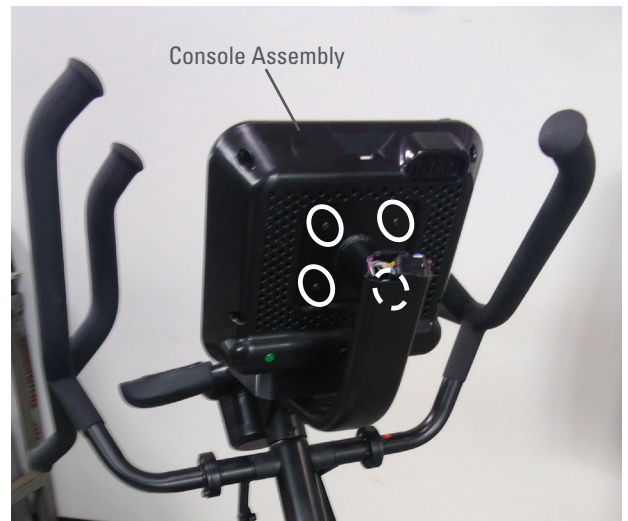

4. Carefully tilt the Console Assembly off of the Static Handlebar and expose the Cable Connections.

Note: Do not crimp any of the Console Cables. This step may require two people.

5. Carefully disconnect the Cables.

Note: Do not crimp any of the Console Cables.

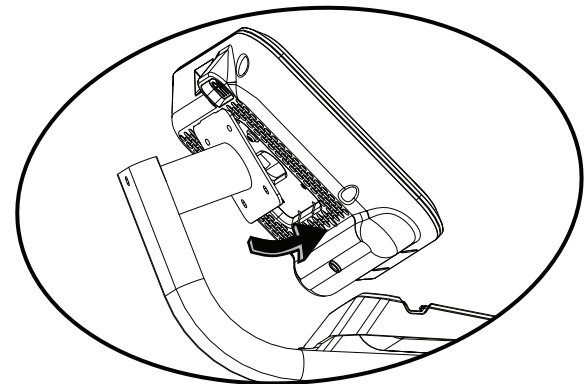

6. Installation is the reverse procedure.

Note: Do not cut or crimp the Cables. Each Cable connector (3-pin, 4-pin, 5-pin and 12-pin) has a corresponding end connector with that many openings. Be sure to fully connect the cable connectors.

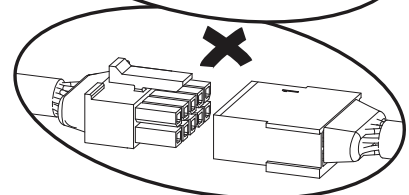
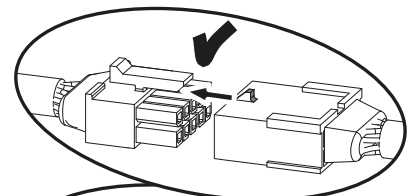

7. Final Inspection

Inspect your machine to ensure that all hardware is tight and components are properly assembled.



Do not use until the machine has been fully assembled and inspected for correct performance in accordance with the Owner's Manual.

NOTICE: This document provides instructions for the replacement of the Console Rear Panel on the Bowflex™ Max Total™ machine / Max Total™ 16/40 / Max Trainer™ M9.

If you need assistance, please contact Customer Service (if purchased in US/Canada) or your local distributor (if purchased outside US/Canada). To find your local distributor, go to: www.nautilusinternational.com

 This icon means a potentially hazardous situation which, if not avoided, could result in death or serious injury. Read and understand all Warnings on this machine.

Nautilus, Inc., www.NautilusInc.com, 5415 Centerpoint Parkway, Groveport, OH 43125 U.S.A. - Customer Service: North America (800) 605-3369, csnls@nautilus.com | outside U.S. www.nautilusinternational.com | Printed in China | © 2019 Nautilus, Inc. | Bowflex, the B logo, Max Total, and Max Trainer are trademarks owned or licensed by Nautilus, Inc., registered or otherwise protected by common law in the United States and other nations. | **ORIGINAL DOCUMENT - ENGLISH VERSION ONLY**

Important Safety Instructions - Before servicing or using this equipment, obey the following warnings:

 This icon means a potentially hazardous situation which, if not avoided, could result in death or serious injury. Read and understand all Warnings on this machine.

- Read and understand the Part Replacement Procedure before working on the machine. Failure to obey the instructions and safety warnings could cause injury to the service technician or bystanders.
- Keep bystanders, children and pets away from the product being serviced at all times.
- Make sure that the repair is done in an appropriate work space away from foot traffic and exposure to bystanders.
- Disconnect all power and allow to sit for 5 minutes before you service this machine.
- Some components of the equipment can be heavy or awkward. Enlist the service of a second person when you do maintenance steps involving these components. Do not try to do heavy or awkward steps on your own.
- If replacement parts are necessary, use only genuine Nautilus replacement parts and hardware. Failure to use genuine replacement parts can cause a risk to users, keep the machine from operating correctly and will void the warranty.
- Be sure that all warning stickers and instructional placards applied to the product stay present and in good condition when doing maintenance or replacing components. If at any time the Warning labels become loose, unreadable or dislodged, replace the labels. If purchased in US/Canada, contact Customer Service for replacement labels. If purchased outside US/Canada, contact your local distributor for them.
- Do not try to change the design or functionality of the machine being serviced as this can adversely effect user safety and will void the warranty.
- Do not use the machine until all shrouds, instructions, warning labels and correct functionality have been verified and tested for correct performance.

• SAVE THESE INSTRUCTIONS.

Tools Required (not included)

#2 Phillips screwdriver

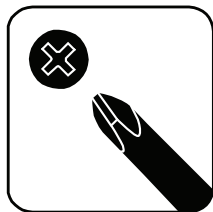

Note: Your machine may not match the images provided exactly.

1. Unplug the AC Adapter from the wall outlet and machine.
2. Remove the Rear Console Cover from the Console Assembly.

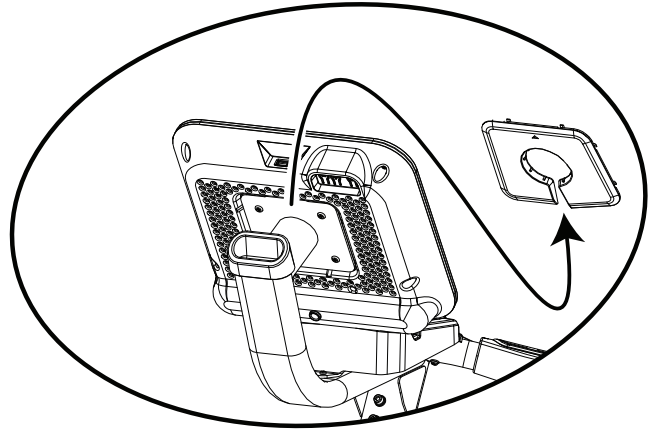

3. Using a #2 Phillips screwdriver, remove the screws (indicated by ovals) from the Console Assembly.

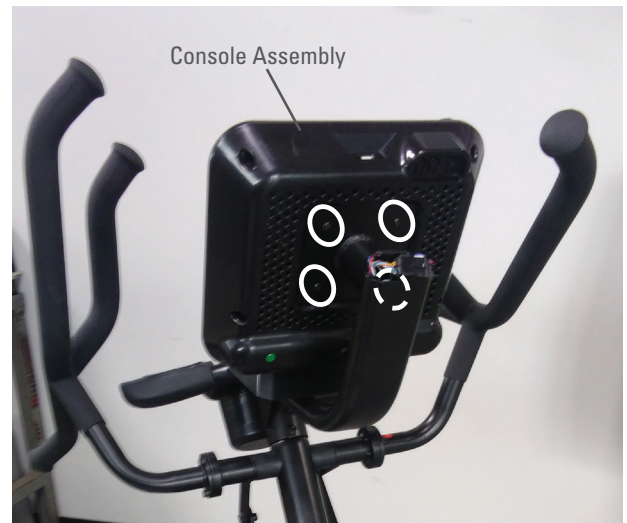

4. Carefully tilt the Console Assembly off of the Static Handlebar and expose the Cable Connections.

Note: Do not crimp any of the Console Cables. This step may require two people.

5. Carefully disconnect the Cables.

Note: Do not crimp any of the Console Cables.

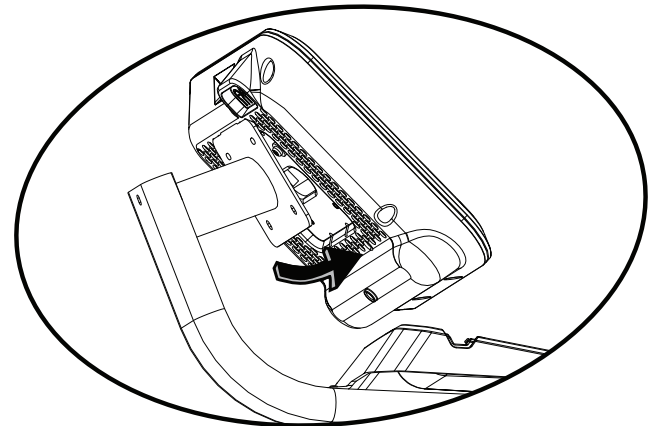

6. To protect the Console display from scratches, gently place the Console Assembly face down on a towel or piece of cardboard.

7. Using a #2 Phillips screwdriver, remove the screws (indicated by arrows) from the back of the Console Assembly.

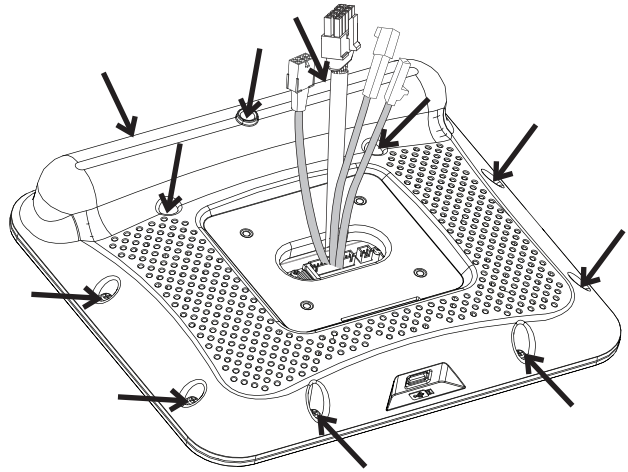

8. Carefully tilt the Console Rear Panel outward off of the Console Assembly, exposing the USB Cable connected to the Console Front Panel.

Note: Do not crimp any of the Cables. This step may require two people.

9. Carefully disconnect the USB Cable from the Console Front Panel to the Console Rear Panel.

Note: Do not crimp any of the Cables.

10. Swap in the new Console Rear Panel.

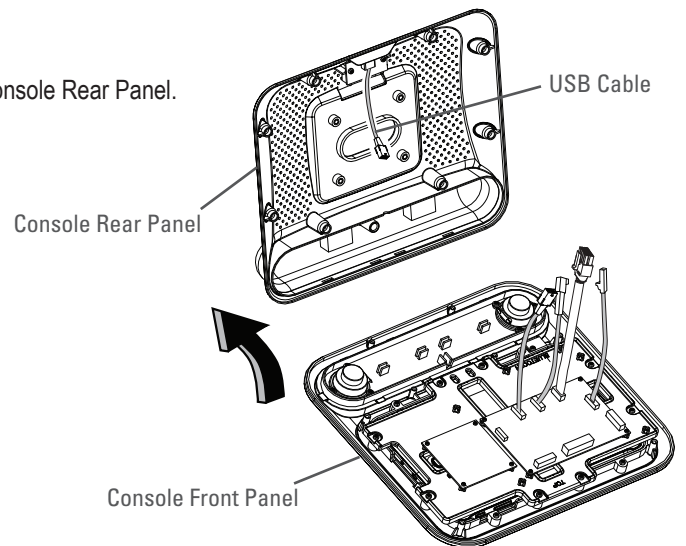

11. Carefully bring the new Console Rear Panel over to the Console Front Panel. Route the four Cables from the Console Front Panel through the opening on the new Console Rear Panel.

Note: Do not crimp any of the Cables. This step may require two people.

12. Carefully connect the USB Cable from the new Console Rear Panel to the Console Front Panel.

Note: Do not crimp any of the Cables.

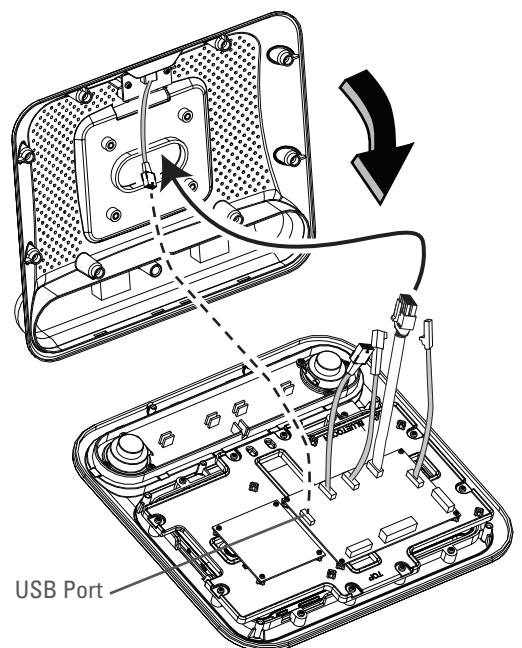

13. Using a #2 Phillips screwdriver, attach the new Console Rear Panel to the Console Front Panel.

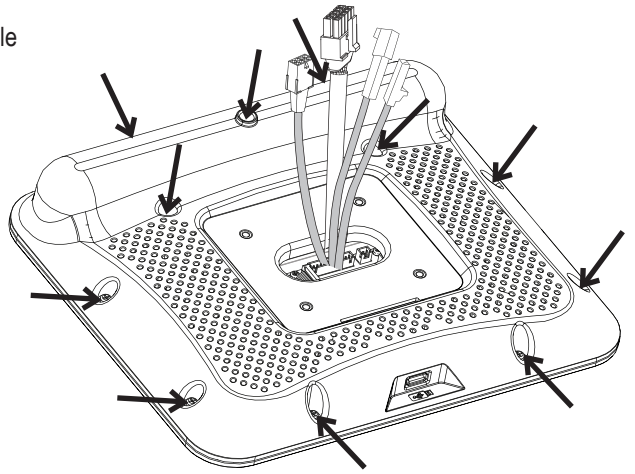

14. Installation is the reverse procedure.

Note: Do not cut or crimp the Cables. Each Cable connector (3-pin, 4-pin, 5-pin and 12-pin) has a corresponding end connector with that many openings. Be sure to fully connect the cable connectors.

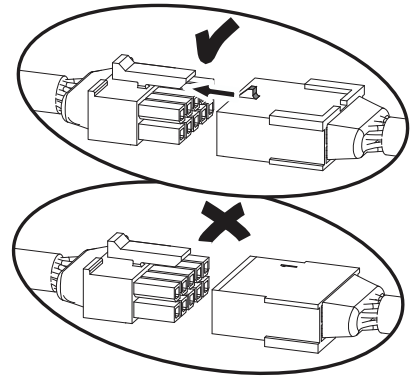

15. Final Inspection

Inspect your machine to ensure that all hardware is tight and components are properly assembled.



Do not use until the machine has been fully assembled and inspected for correct performance in accordance with the Owner's Manual.

NOTICE: This document provides instructions for the replacement of the Left Crank Arm on the Bowflex™ Max Total™ machine and Max Total™ 16/40.

If you need assistance, please contact Customer Service (if purchased in US/Canada) or your local distributor (if purchased outside US/Canada). To find your local distributor, go to: www.nautilusinternational.com

This icon means a potentially hazardous situation which, if not avoided, could result in death or serious injury. Read and understand all Warnings on this machine.

Nautilus, Inc., www.NautilusInc.com, 5415 Centerpoint Parkway, Groveport, OH 43125 U.S.A. - Customer Service: North America (800) 605-3369, csnlis@nautilus.com | outside U.S. www.nautilusinternational.com | Printed in China | © 2019 Nautilus, Inc. | Bowflex, the B logo, and Max Total are trademarks owned or licensed by Nautilus, Inc., registered or otherwise protected by common law in the United States and other nations. | **ORIGINAL DOCUMENT - ENGLISH VERSION ONLY**

Important Safety Instructions - Before servicing or using this equipment, obey the following warnings:

This icon means a potentially hazardous situation which, if not avoided, could result in death or serious injury. Read and understand all Warnings on this machine.

- Read and understand the Part Replacement Procedure before working on the machine. Failure to obey the instructions and safety warnings could cause injury to the service technician or bystanders.
- Keep bystanders, children and pets away from the product being serviced at all times.
- Make sure that the repair is done in an appropriate work space away from foot traffic and exposure to bystanders.
- Disconnect all power and allow to sit for 5 minutes before you service this machine.
- Some components of the equipment can be heavy or awkward. Enlist the service of a second person when you do maintenance steps involving these components. Do not try to do heavy or awkward steps on your own.
- If replacement parts are necessary, use only genuine Nautilus replacement parts and hardware. Failure to use genuine replacement parts can cause a risk to users, keep the machine from operating correctly and will void the warranty.
- Be sure that all warning stickers and instructional placards applied to the product stay present and in good condition when doing maintenance or replacing components. If at any time the Warning labels become loose, unreadable or dislodged, replace the labels. If purchased in US/Canada, contact Customer Service for replacement labels. If purchased outside US/Canada, contact your local distributor for them.
- Do not try to change the design or functionality of the machine being serviced as this can adversely effect user safety and will void the warranty.
- Do not use the machine until all shrouds, instructions, warning labels and correct functionality have been verified and tested for correct performance.

• SAVE THESE INSTRUCTIONS.

Tools Required (not included)

#2 Phillips screwdriver

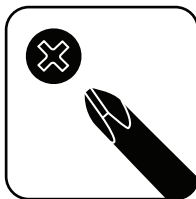

Adjustable wrench



5mm hex wrench
6mm hex wrench



9/16" or 14mm Socket and Wrench



Crank Puller (non-handled,
JIS/ISO square taper
with M22x1.0 threads)

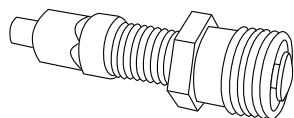

Note: Your machine may not match the images provided exactly.

1. Remove the indicated Cap from the left side of the machine.

2. Using a 6mm hex wrench, remove the hardware exposed from below the Cap.

3. Lift the Foot Pedal and slide the Leg Assembly straight off the machine. Be sure to pull straight out, or the Leg Assembly may be difficult to remove.

4. Remove the Wave Washer from the Crank Arm, and place it in a secure location for re-use.

5. Using a 5mm hex wrench, remove the indicated hardware from the Left Upper Handlebar and place it out of the work area.

Note: Be aware that the Left Upper Handlebar must be supported when removing the hardware.



5. Using a 5mm hex wrench, remove the indicated hardware from the Left Upper Handlebar and place it out of the work area.

Note: Be aware that the Left Upper Handlebar must be supported when removing the hardware.



6. Place a rag or protective material below the Connector Arm to protect the Shrouds from potential scratches from the Connector Arms.

7. Using a 6mm hex wrench, remove the hardware that connects the Connector Arm and the Pivot Arm.

Note: The Connector Arm will pivot downward if not lowered slowly onto the rag protecting the Shroud.

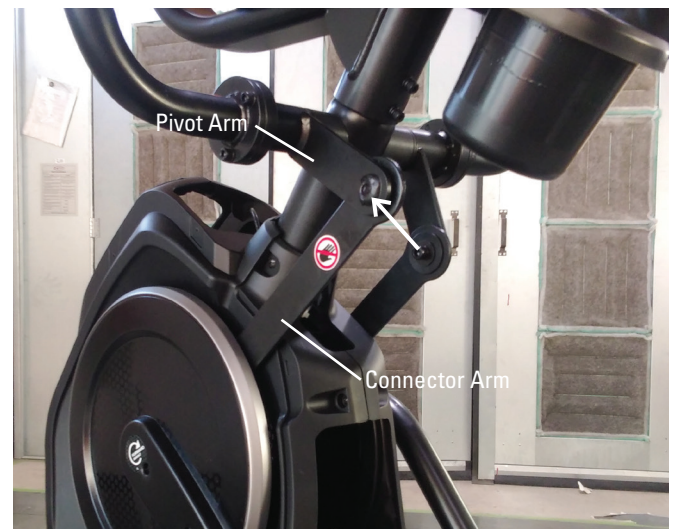

8. Using a #2 Phillips screwdriver, remove the 2 indicated screws from the Left Crank Cover.

Note: The Left Crank Cover screws may have been over-tightened when installed. Try not to strip the screws when removing them.

9. Remove the Left Crank Cover from the machine.



10. Using a 9/16" or 14mm socket and wrench, remove the indicated nut from the Crank Assembly.



11. Adjust the Crank Puller until the end of the Bolt is inside the Nut (as shown).



12. Carefully thread the Crank Puller into the Left Crank Arm. Be sure the Crank Puller has at least three rounds of threads inserted.

13. Using an adjustable wrench, turn the inner portion (the Bolt) of the Crank Puller clockwise. The Crank Arm will slide off as it is tightened.

Note: Be aware that the Crank Arm will be loose and will need to be supported.

14. Remove the Crank Puller from the Crank Arm.



15. Installation is the reverse procedure excluding steps with the Crank Puller. The Crank Puller is not required for re-assembly.

Note: When replacing the Crank Arm be sure the Right and Left Crank Arms are oriented inline and opposite each other.

The Crank Nut should be tightened to a torque value of 29-32.5 ft lbs (or 350-390 in lbs).

16. Final Inspection

Inspect your machine to ensure that all hardware is tight and components are properly assembled.

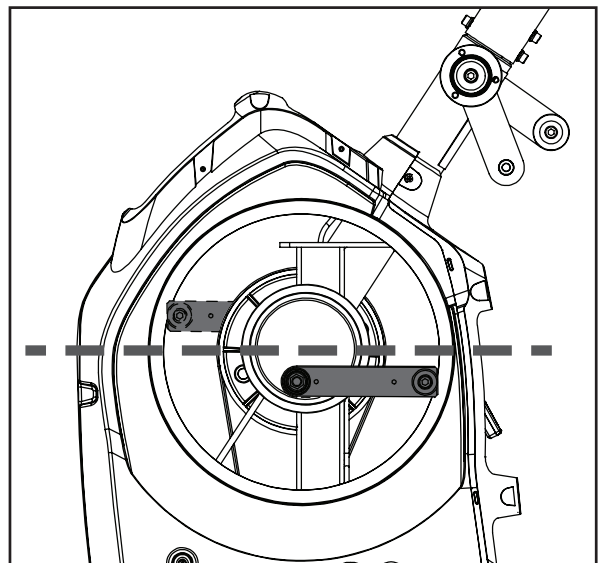

Do not use until the machine has been fully assembled and inspected for correct performance in accordance with the Owner's Manual.

NOTICE: This document provides instructions for the replacement of the Right Crank Arm on the Bowflex™ Max Total™ machine and Max Total™ 16/40.

If you need assistance, please contact Customer Service (if purchased in US/Canada) or your local distributor (if purchased outside US/Canada). To find your local distributor, go to: www.nautilusinternational.com

This icon means a potentially hazardous situation which, if not avoided, could result in death or serious injury. Read and understand all Warnings on this machine.

Nautilus, Inc., www.NautilusInc.com, 5415 Centerpoint Parkway, Groveport, OH 43125 U.S.A. - Customer Service: North America (800) 605-3369, csnls@nautilus.com | outside U.S. www.nautilusinternational.com | Printed in China | © 2019 Nautilus, Inc. | Bowflex, the B logo, and Max Total are trademarks owned or licensed by Nautilus, Inc., registered or otherwise protected by common law in the United States and other nations. | **ORIGINAL DOCUMENT - ENGLISH VERSION ONLY**

Important Safety Instructions - Before servicing or using this equipment, obey the following warnings:

This icon means a potentially hazardous situation which, if not avoided, could result in death or serious injury. Read and understand all Warnings on this machine.

- Read and understand the Part Replacement Procedure before working on the machine. Failure to obey the instructions and safety warnings could cause injury to the service technician or bystanders.
- Keep bystanders, children and pets away from the product being serviced at all times.
- Make sure that the repair is done in an appropriate work space away from foot traffic and exposure to bystanders.
- Disconnect all power and allow to sit for 5 minutes before you service this machine.
- Some components of the equipment can be heavy or awkward. Enlist the service of a second person when you do maintenance steps involving these components. Do not try to do heavy or awkward steps on your own.
- If replacement parts are necessary, use only genuine Nautilus replacement parts and hardware. Failure to use genuine replacement parts can cause a risk to users, keep the machine from operating correctly and will void the warranty.
- Be sure that all warning stickers and instructional placards applied to the product stay present and in good condition when doing maintenance or replacing components. If at any time the Warning labels become loose, unreadable or dislodged, replace the labels. If purchased in US/Canada, contact Customer Service for replacement labels. If purchased outside US/Canada, contact your local distributor for them.
- Do not try to change the design or functionality of the machine being serviced as this can adversely effect user safety and will void the warranty.
- Do not use the machine until all shrouds, instructions, warning labels and correct functionality have been verified and tested for correct performance.

• SAVE THESE INSTRUCTIONS.

Tools Required (not included)

#2 Phillips screwdriver

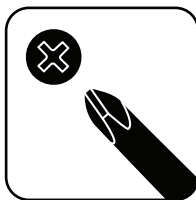

Adjustable wrench



5mm hex wrench
6mm hex wrench



9/16" or 14mm Socket and Wrench



Crank Puller (non-handled,
JIS/ISO square taper
with M22x1.0 threads)

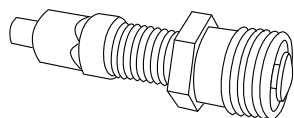

Note: Your machine may not match the images provided exactly.

1. Remove the Cap from the right side of the machine.
2. Using a 6mm hex wrench, remove the hardware exposed from below the Cap.
3. Lift the Foot Pedal and slide the Leg Assembly straight off the machine. Be sure to pull straight out, or the Leg Assembly may be difficult to remove.
4. Remove the Wave Washer from the Crank Arm, and place it in a secure location for re-use.



5. Using a 5mm hex wrench, remove the indicated hardware from the Right Upper Handlebar and place it out of the work area.

Note: Be aware that the Upper Handlebar must be supported when removing the hardware.

6. Place a rag or protective material below the Connector Arm to protect the Shrouds from potential scratches from the Connector Arms.

7. Using a 6mm hex wrench, remove the hardware that connects the Connector Arm and the Pivot Arm.

Note: The Connector Arm will pivot downward if not lowered slowly onto the rag protecting the Shroud.



8. Using a #2 Phillips screwdriver, remove the 4 screws (2 indicated on one side) from the Upper Shroud.

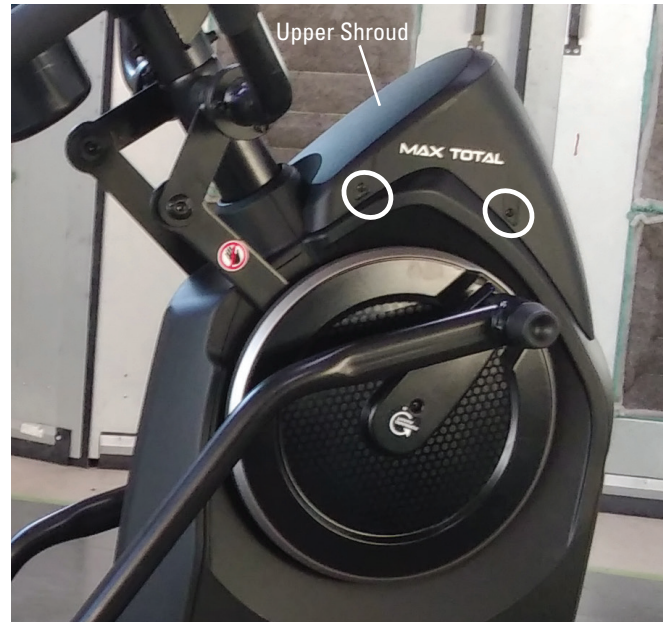

9. Using a #2 Phillips screwdriver, remove the 2 indicated screws from the Crank Cover.

Note: The Crank Cover screws may have been over-tightened when installed. Try not to strip the screws when removing them.

10. Remove the Crank Cover from the machine.



11. Place a towel or rag inside of the machine below the indicated screws (with arrows). The towel or rag should be placed so that it will catch the screws if dropped.

12. Using a #2 Phillips screwdriver, remove the screws (indicated by arrows) that secure the Upper Body Sensor. Allow the Upper Body Sensor to hang on the Cable, away from the Right Crank Arm.

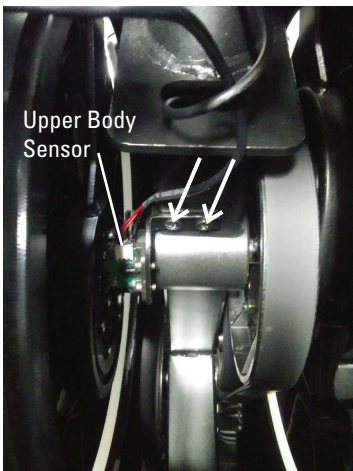

Note: View into Shrouds from above.

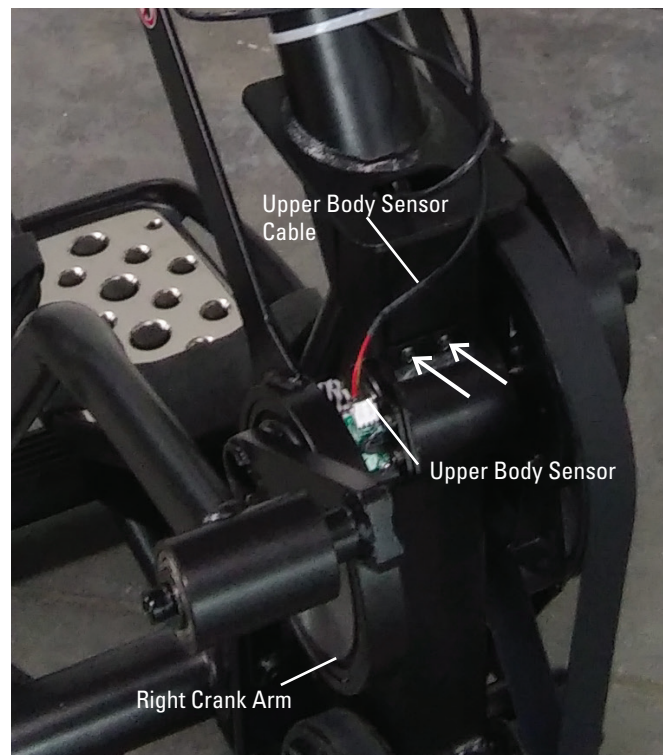

Note: Shrouds are removed for clarity.

13. Using a 9/16" or 14mm socket and wrench, remove the indicated nut from the Crank Assembly.



14. Adjust the Crank Puller until the end of the Bolt is inside the Nut (as shown).



15. Carefully thread the Crank Puller into the Crank Arm. Be sure the Crank Puller has at least three rounds of threads inserted.

16. Using an adjustable wrench, turn the inner portion (the Bolt) of the Crank Puller clockwise. The Crank Arm Assembly will slide off as it is tightened.

Note: Be aware that the Crank Arm Assembly will be loose and will need to be supported.

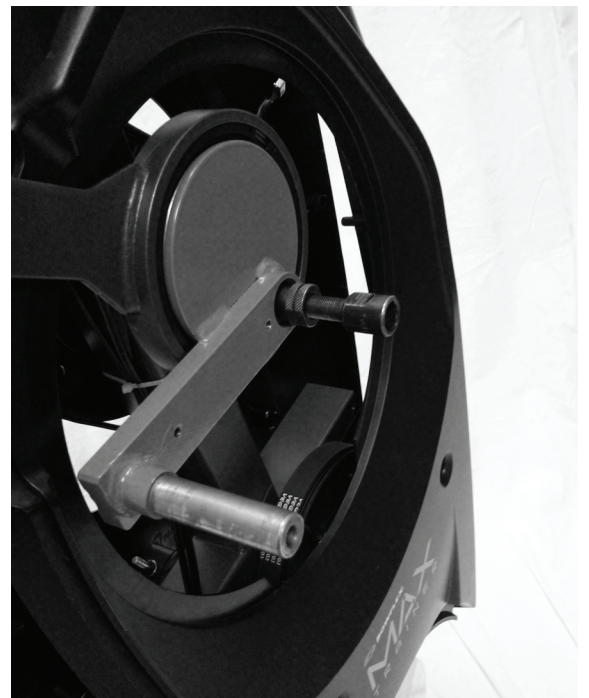

17. Remove the Crank Puller from the Crank Arm.

18. Slide the new Right Crank Arm Assembly onto the machine.

Note: Be sure not to damage or break the Codewheel on the new Right Crank Arm or the one still remaining on the machine.

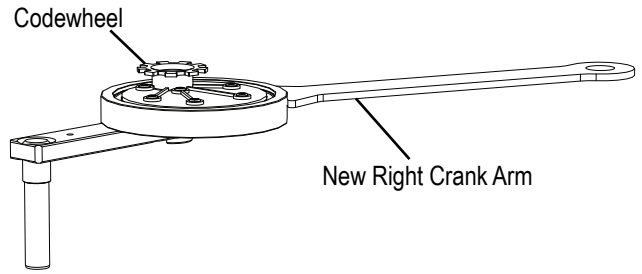

19. Re-attach the Upper Body Sensor so that it is centered on the Codewheels.

20. With the Upper Body Sensor centered on the Codewheels, confirm that the Upper Body Sensor does not rub anything by using the machine briefly. Adjust the Upper Body Sensor as necessary.

21. Installation is the reverse procedure excluding steps with the Crank Puller. The Crank Puller is not required for re-assembly.

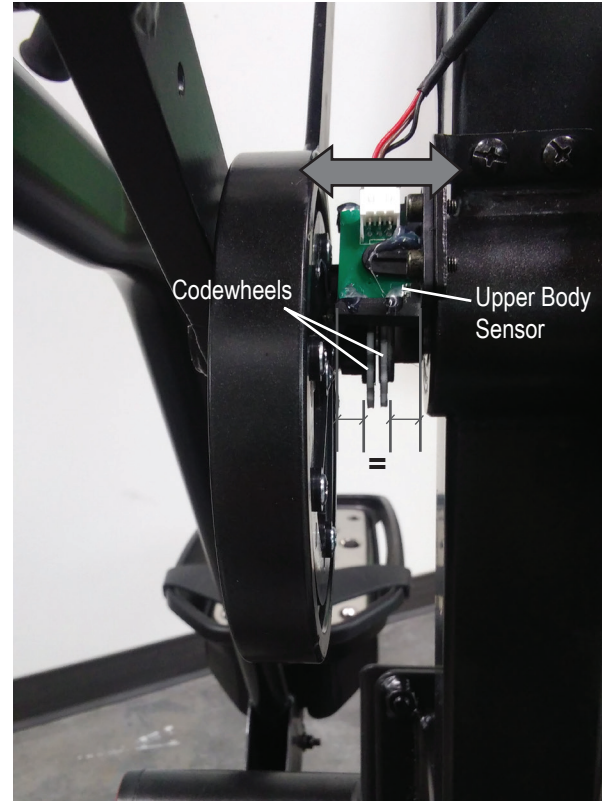

Note: The image shows a properly installed Upper Body Sensor. Shrouds are removed for clarity.

Note: When replacing the Right Crank Arm, be sure the Right and Left Crank Arms are oriented inline and opposite each other. The Crank Nut should be tightened to a torque value of 29-32.5 ft lbs (or 350-390 in lbs).

22. Final Inspection

Inspect your machine to ensure that all hardware is tight and components are properly assembled.



Do not use until the machine has been fully assembled and inspected for correct performance in accordance with the Owner's Manual.

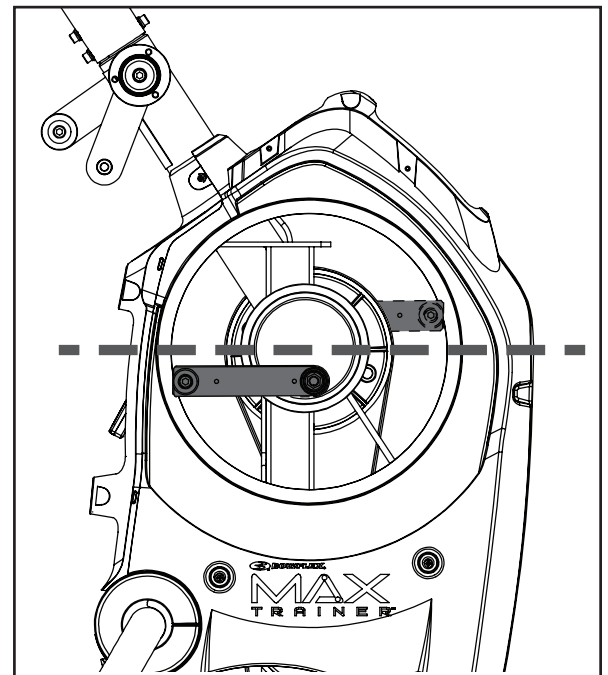

NOTICE: This document provides instructions for the replacement of the Drive Belt on the Bowflex™ Max Total™ machine / Max Total™ 16/40 / Max Trainer™ M9.

If you need assistance, please contact Customer Service (if purchased in US/Canada) or your local distributor (if purchased outside US/Canada). To find your local distributor, go to: www.nautilusinternational.com



This icon means a potentially hazardous situation which, if not avoided, could result in death or serious injury. Read and understand all Warnings on this machine.

Nautilus, Inc., www.NautilusInc.com, 5415 Centerpoint Parkway, Groveport, OH 43125 U.S.A. - Customer Service: North America (800) 605-3369, csnls@nautilus.com | outside U.S. www.nautilusinternational.com | Printed in China | © 2019 Nautilus, Inc. | Bowflex, the B logo, Max Total, and Max Trainer are trademarks owned or licensed by Nautilus, Inc., registered or otherwise protected by common law in the United States and other nations. | **ORIGINAL DOCUMENT - ENGLISH VERSION ONLY**

Important Safety Instructions - Before servicing or using this equipment, obey the following warnings:



This icon means a potentially hazardous situation which, if not avoided, could result in death or serious injury. Read and understand all Warnings on this machine.

- Read and understand the Part Replacement Procedure before working on the machine. Failure to obey the instructions and safety warnings could cause injury to the service technician or bystanders.
- Keep bystanders, children and pets away from the product being serviced at all times.
- Make sure that the repair is done in an appropriate work space away from foot traffic and exposure to bystanders.
- Disconnect all power and allow to sit for 5 minutes before you service this machine.
- Some components of the equipment can be heavy or awkward. Enlist the service of a second person when you do maintenance steps involving these components. Do not try to do heavy or awkward steps on your own.
- If replacement parts are necessary, use only genuine Nautilus replacement parts and hardware. Failure to use genuine replacement parts can cause a risk to users, keep the machine from operating correctly and will void the warranty.
- Be sure that all warning stickers and instructional placards applied to the product stay present and in good condition when doing maintenance or replacing components. If at any time the Warning labels become loose, unreadable or dislodged, replace the labels. If purchased in US/Canada, contact Customer Service for replacement labels. If purchased outside US/Canada, contact your local distributor for them.
- Do not try to change the design or functionality of the machine being serviced as this can adversely effect user safety and will void the warranty.
- Do not use the machine until all shrouds, instructions, warning labels and correct functionality have been verified and tested for correct performance.

• SAVE THESE INSTRUCTIONS.

Tools Required (not included)

#2 Phillips screwdriver

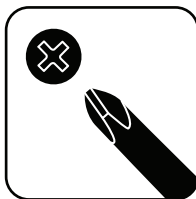

#2 Standard screwdriver



4mm hex wrench
6mm hex wrench
8mm hex wrench



Note: Your machine may not match the images provided exactly.

1. Unplug the AC Adapter from the wall outlet and machine.

3. Using a 6mm hex wrench, remove the indicated hardware from the Upper Handlebars and place them out of the work area.

Note: Be aware that the Upper Handlebars must be supported when removing the hardware.



2. Using a #2 Phillips screwdriver, remove the 4 screws (2 indicated on one side) from the Upper Shroud and remove it.



4. Remove the Right and Left Stabilizer Shrouds from the machine (if equipped).

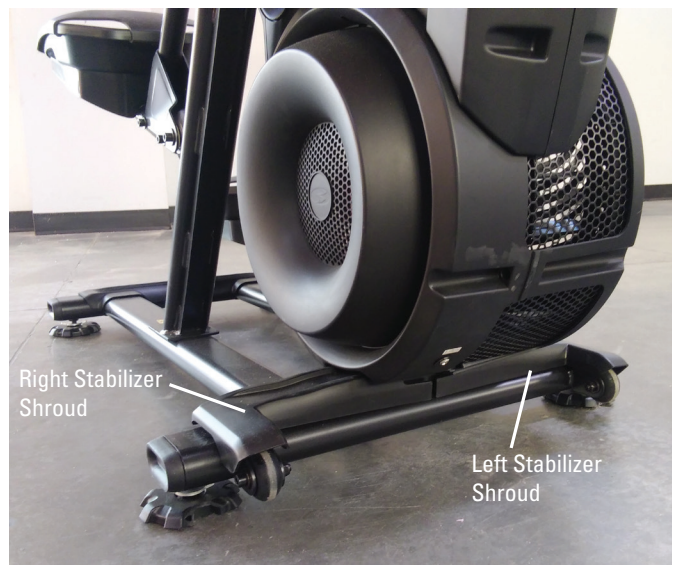

5. Using a #2 Phillips screwdriver, remove the indicated (by ovals) screws and only loosen the lowest indicated screw (arrow) from the Right Fan Cover.

6. The Right Fan Cover has a tab that needs to be pushed upward to clear the loosened screw. While pushing up on the tab, remove the Right Fan Cover from the assembly.

Note: The Power Cable is attached to the inside of the Right Fan Cover. Be sure not to crimp the cable by placing the Right Fan Cover close to the front of the machine.

To assist with assembly, note that the upper screw is a machine screw and not a self-tapping screw.

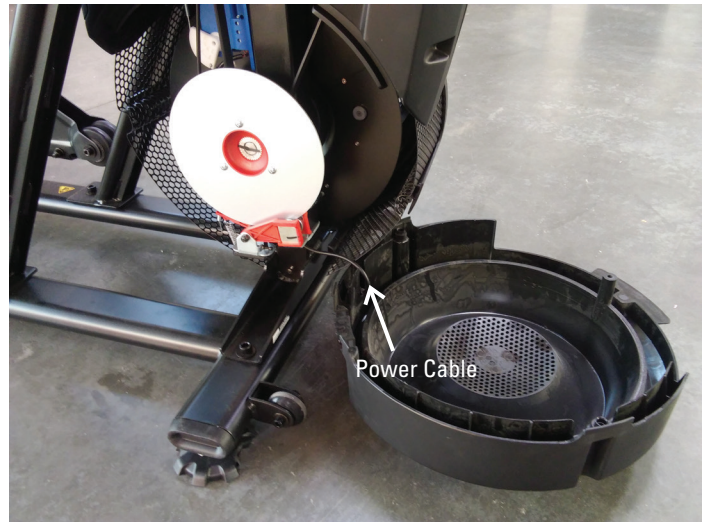
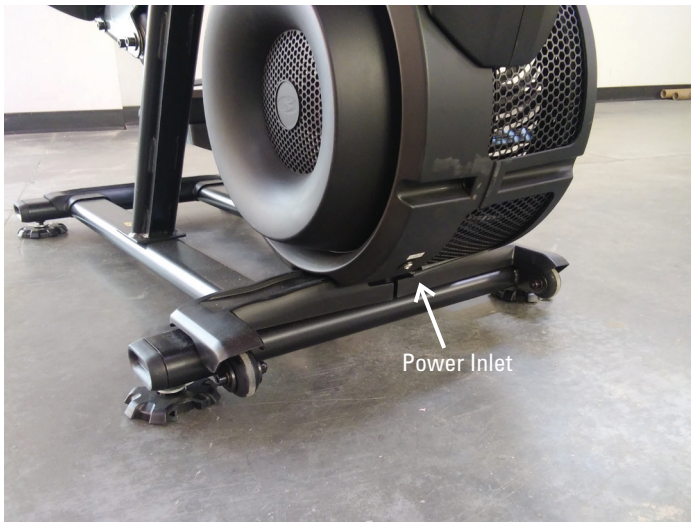
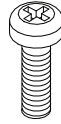

7. Remove the indicated Cap from the left side of the machine.

8. Using a 6mm hex wrench, remove the hardware exposed from below the Cap.

9. Lift the Foot Pedal and slide the Leg Assembly straight off the machine. Be sure to pull straight out, or the Leg Assembly may be difficult to remove.

Note: A rubber mallet may be necessary if the Leg Assembly will not slide off.

10. Remove the Wave Washer from the Crank Arm, and place it in a secure location for re-use.



11. Using a #2 Phillips screwdriver, remove the indicated screw from the Rear Shroud.

12. Carefully remove the Rear Shroud from the machine. Place a standard screwdriver behind and near the middle of the Rear Shroud and gently pry until it releases. Then move the screwdriver to the bottom and gently pry until the Rear Shroud comes off.

13. Remove the indicated Caps from the machine.



14. Using a #2 Phillips screwdriver, remove the indicated (by oval) screw and only loosen the lowest indicated screw (arrow) from the Left Fan Cover.

15. The Left Fan Cover Assembly has a tab that needs to be pushed upward to clear the loosened screw. While pushing up on the tab, remove the Left Fan Cover Assembly.

16. Remove the Left Fan Cover Assembly from the machine. Be sure to note how the fan screens are set into the Left Fan Cover to assist with the replacement procedure.



17. Using a #2 Phillips screwdriver, remove the 2 indicated (by ovals) screws from the Crank Cover. Repeat on the other side of the machine.

18. Remove the Crank Covers from the machine.

Note: The Crank Cover screws may have been over-tightened when installed. Try not to strip the screws when removing them.

19. Place a rag or protective material below the Connector Arm to protect the Shrouds from potential scratches from the Connector Arms.

20. Using a 6mm hex wrench, remove the hardware (indicated by arrows) that connects the Connector Arms and the Pivot Arms.

Note: The Connector Arm will pivot downward if not lowered slowly onto the rag protecting the Shrouds

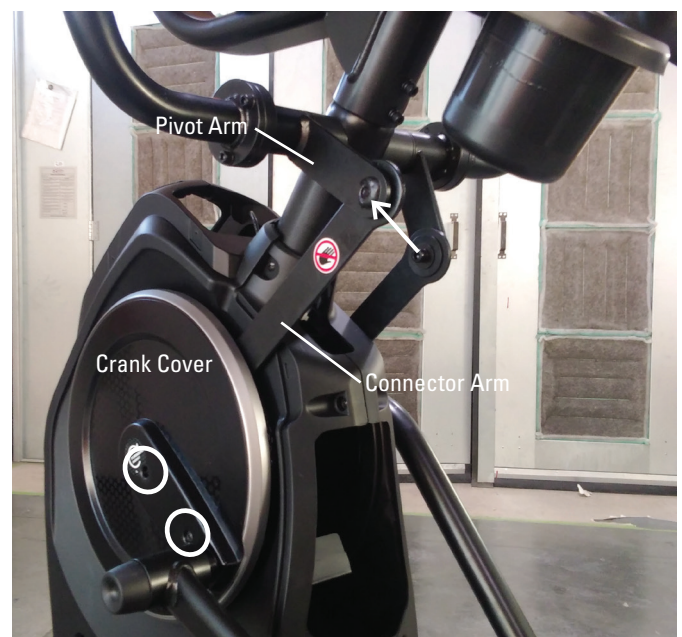

21. Using a #2 Phillips screwdriver, remove the screws from the Left Shroud. (9 screws on the Left Shroud) Remove the upper screws labeled ' * ' last.

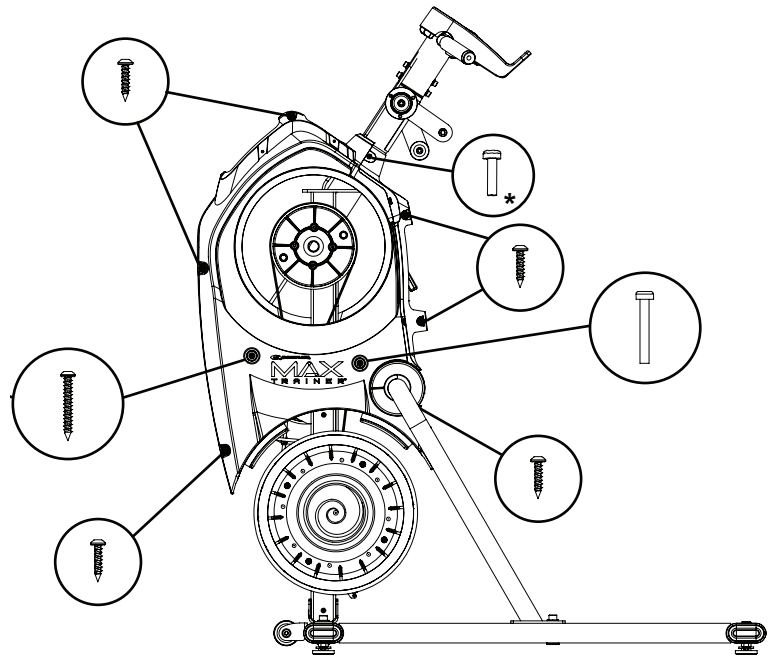

Left Side

22. Using a 4mm hex wrench, remove the screw indicated by "A" from the Drive Belt Tensioner Arm.

23. Using a 8mm hex wrench, loosen the screw indicated by "B" until the Drive Belt is free enough to be removed from the Drive Pulley. Remove the Drive Belt.

⚠ Keep fingers out of any pinch opportunities when removing the Fan Belt.

24. Replace and tighten the "A" screw on the Drive Belt Tensioner Arm, and then tighten the "B" screw.

25. Installation is the reverse procedure.

26. Final Inspection
Inspect your machine to ensure that all hardware is tight and components are properly assembled.

⚠ Do not use until the machine has been fully assembled and inspected for correct performance in accordance with the Owner's Manual.

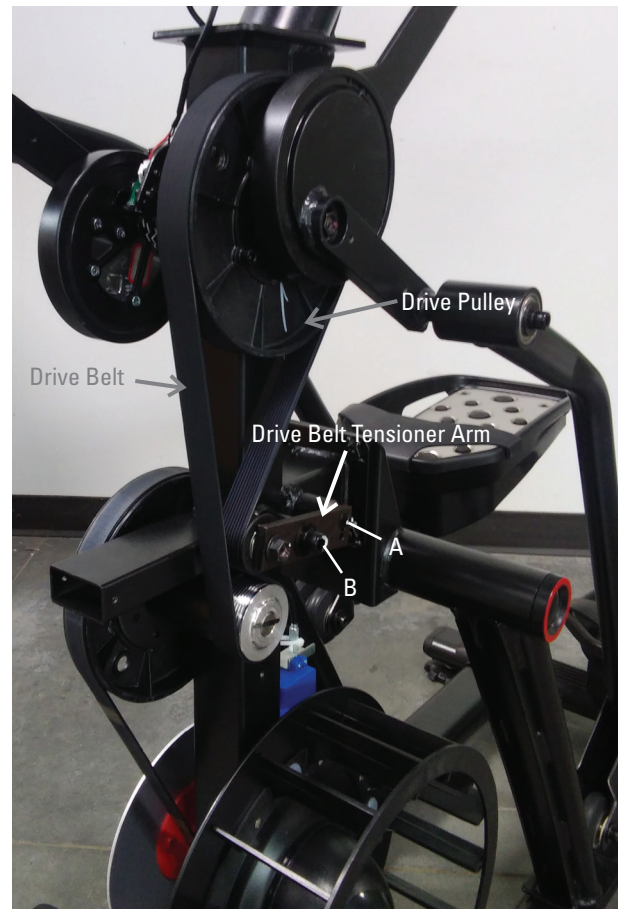

Note: Shrouds are removed for clarity.

NOTICE: This document provides instructions for the replacement of the Drive Pulley on the Bowflex™ Max Total™ machine / Max Total™ 16/40 / Max Trainer™ M9.

If you need assistance, please contact Customer Service (if purchased in US/Canada) or your local distributor (if purchased outside US/Canada). To find your local distributor, go to: www.nautilusinternational.com

This icon means a potentially hazardous situation which, if not avoided, could result in death or serious injury. Read and understand all Warnings on this machine.

Nautilus, Inc., www.NautilusInc.com, 5415 Centerpoint Parkway, Groveport, OH 43125 U.S.A. - Customer Service: North America (800) 605-3369, csnlis@nautilus.com | outside U.S. www.nautilusinternational.com | Printed in China | © 2020 Nautilus, Inc. | Bowflex, the B logo, Max Total, and Max Trainer are trademarks owned or licensed by Nautilus, Inc., registered or otherwise protected by common law in the United States and other nations. | ORIGINAL DOCUMENT - ENGLISH VERSION ONLY

Important Safety Instructions - Before servicing or using this equipment, obey the following warnings:

This icon means a potentially hazardous situation which, if not avoided, could result in death or serious injury. Read and understand all Warnings on this machine.

- Read and understand the Part Replacement Procedure before working on the machine. Failure to obey the instructions and safety warnings could cause injury to the service technician or bystanders.
- Keep bystanders, children and pets away from the product being serviced at all times.
- Make sure that the repair is done in an appropriate work space away from foot traffic and exposure to bystanders.
- Disconnect all power and allow to sit for 5 minutes before you service this machine.
- Some components of the equipment can be heavy or awkward. Enlist the service of a second person when you do maintenance steps involving these components. Do not try to do heavy or awkward steps on your own.
- If replacement parts are necessary, use only genuine Nautilus replacement parts and hardware. Failure to use genuine replacement parts can cause a risk to users, keep the machine from operating correctly and will void the warranty.
- Be sure that all warning stickers and instructional placards applied to the product stay present and in good condition when doing maintenance or replacing components. If at any time the Warning labels become loose, unreadable or dislodged, replace the labels. If purchased in US/Canada, contact Customer Service for replacement labels. If purchased outside US/Canada, contact your local distributor for them.
- Do not try to change the design or functionality of the machine being serviced as this can adversely effect user safety and will void the warranty.
- Do not use the machine until all shrouds, instructions, warning labels and correct functionality have been verified and tested for correct performance.

• SAVE THESE INSTRUCTIONS.

Tools Required (not included)

#2 Phillips screwdriver

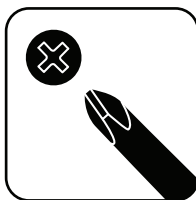

10mm wrench
16mm wrench

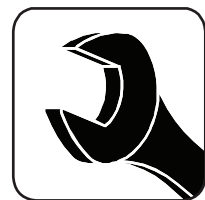

4mm hex wrench
5mm hex wrench
6mm hex wrench
8mm hex wrench



#2 Standard screwdriver



9/16" or 14mm Socket and Wrench



Crank Puller (non-handled,
JIS/ISO square taper
with M22x1.0 threads)

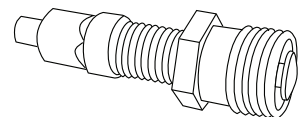

1. Unplug the AC Adapter from the wall outlet and machine.

2. Using a 5mm hex wrench, remove the indicated hardware from the Left Upper Handlebar and place it out of the work area.

Note: Be aware that the Upper Handlebar must be supported when removing the hardware.



2. Using a #2 Phillips screwdriver, remove the 4 screws (2 indicated on one side) from the Upper Shroud and remove it.



4. Remove the Right and Left Stabilizer Shrouds from the machine.

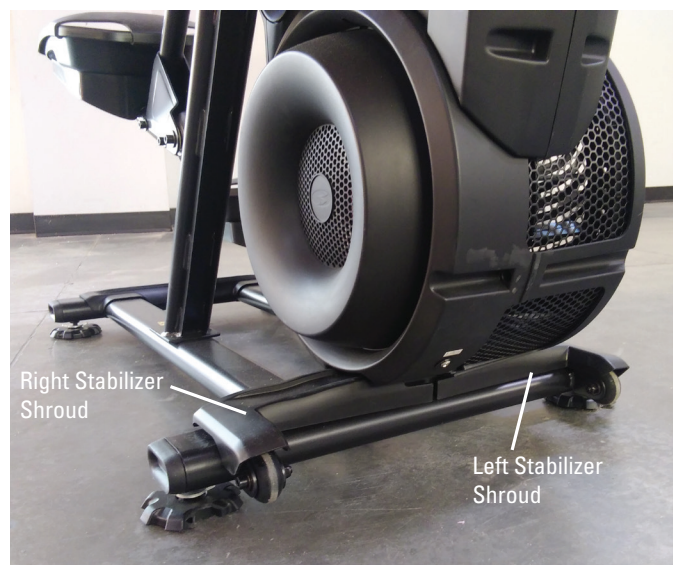

5. Using a #2 Phillips screwdriver, remove the indicated (by ovals) screws and only loosen the lowest indicated screw (arrow) from the Right Fan Cover.

6. The Right Fan Cover has a tab that needs to be pushed upward to clear the loosened screw. While pushing up on the tab, remove the Right Fan Cover from the assembly.

Note: the Power Cable is attached to the inside of the Right Fan Cover. Be sure not to crimp the cable by placing the Right Fan Cover close to the front of the machine.

To assist with assembly, note that the upper screw is a machine screw and not a self-tapping screw.

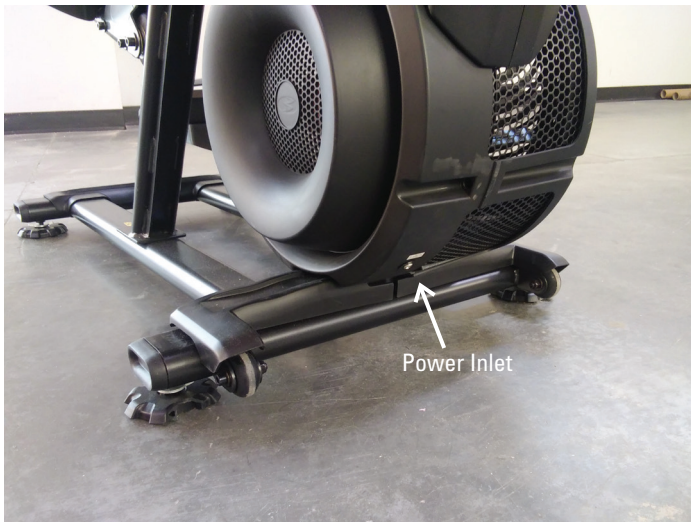
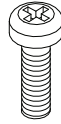

7. Remove the indicated Cap from the machine.

8. Using a 6mm hex wrench, remove the hardware exposed from below the Cap.

9. Slide the Left Leg Assembly off of the machine.



10. Using a #2 Phillips screwdriver, remove the indicated screw from the Rear Shroud.

11. Carefully remove the Rear Shroud from the machine. Place a standard screwdriver behind and near the middle of the Rear Shroud and gently pry until it releases. Then move the screwdriver to the bottom and gently pry until the Rear Shroud comes off.



12. Using a #2 Phillips screwdriver, remove the indicated (by oval) screw and only loosen the lowest indicated screw (arrow) from the Left Fan Cover.

13. The Left Fan Cover Assembly has a tab that needs to be pushed upward to clear the loosened screw. While pushing up on the tab, remove the Left Fan Cover Assembly.

14. Remove the Left Fan Cover Assembly from the machine. Be sure to note how the fan screens are set into the Left Fan Cover to assist with the replacement procedure.



15. Using a #2 Phillips screwdriver, remove the 2 indicated screws from the Left Crank Cover.

16. Remove the Left Crank Cover from the machine.

17. Place a rag or protective material below the Left Connector Arm to protect the Shroud from potential scratches from the Connector Arm.

18. Using a 6mm hex wrench, remove the hardware that connects the Left Connector Arm and the Pivot Arm.

Note: The Connector Arm will pivot downward if not lowered slowly onto the rag protecting the Shroud.

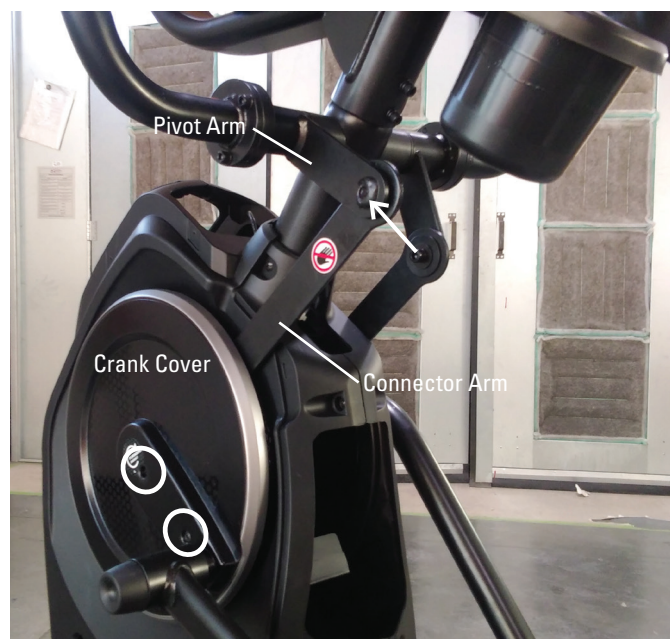

19. Using a 9/16" or 14mm socket and wrench, remove the nut from the Left Crank Assembly.



20. Adjust the Crank Puller until the end of the Bolt is inside the Nut (as shown).



21. Carefully thread the Crank Puller into the Left Crank Arm. Be sure the Crank Puller has at least three rounds of threads inserted.

22. Using a 16mm wrench, turn the inner portion (the Bolt) of the Crank Puller clockwise. The Left Crank Arm will slide off as it is tightened.

Note: Be aware that the Left Crank Arm will be loose and will need to be supported.

23. Remove the Crank Puller from the Left Crank Arm.



24. Using a #2 Phillips screwdriver, remove the screws from the Left Shroud. (9 screws on the Left Shroud) Remove the upper screws labeled ' * ' last.

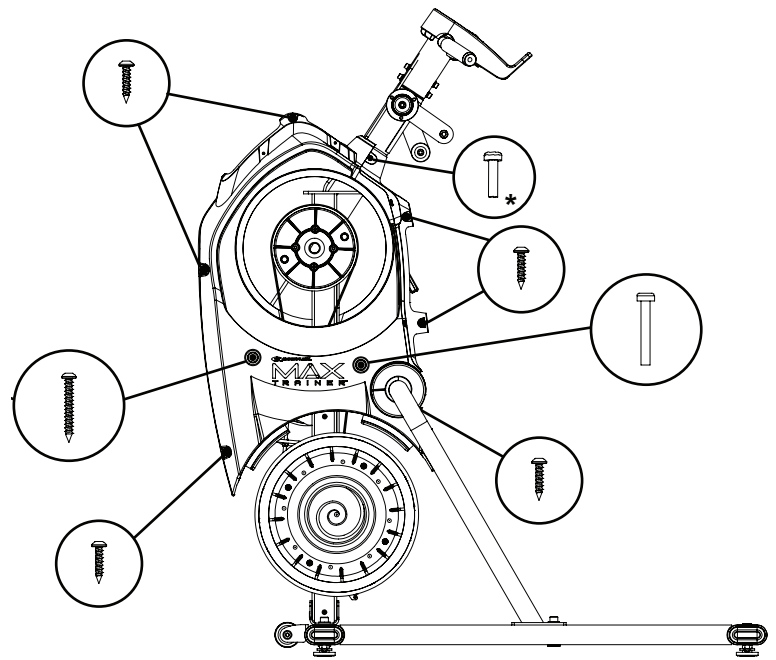

Left Side

25. Using a 4mm hex wrench, remove the screw indicated by "A" from the Drive Belt Tensioner Arm.

26. Using a 10mm wrench, remove the securing nuts (if present) from the back side of the Drive Pulley.

27. Using a 8mm hex wrench, loosen the screw indicated by "B" until the Drive Belt is free enough to be removed from the Drive Pulley. Remove the Drive Belt.

 **Keep fingers out of any pinch opportunities when removing the Fan Belt.**

28. Using a 5mm hex wrench, remove the four screws that attach the Drive Pulley. Be sure to support the weight of the Drive Pulley when removing hardware because it will fall.

29. Using a 5mm hex wrench, attach the new Drive Pulley to the Frame Assembly.

30. Replace the Drive Belt around the new Drive Pulley.

31. Replace and tighten the "A" screw on the Drive Belt Tensioner Arm, and then tighten the "B" screw.

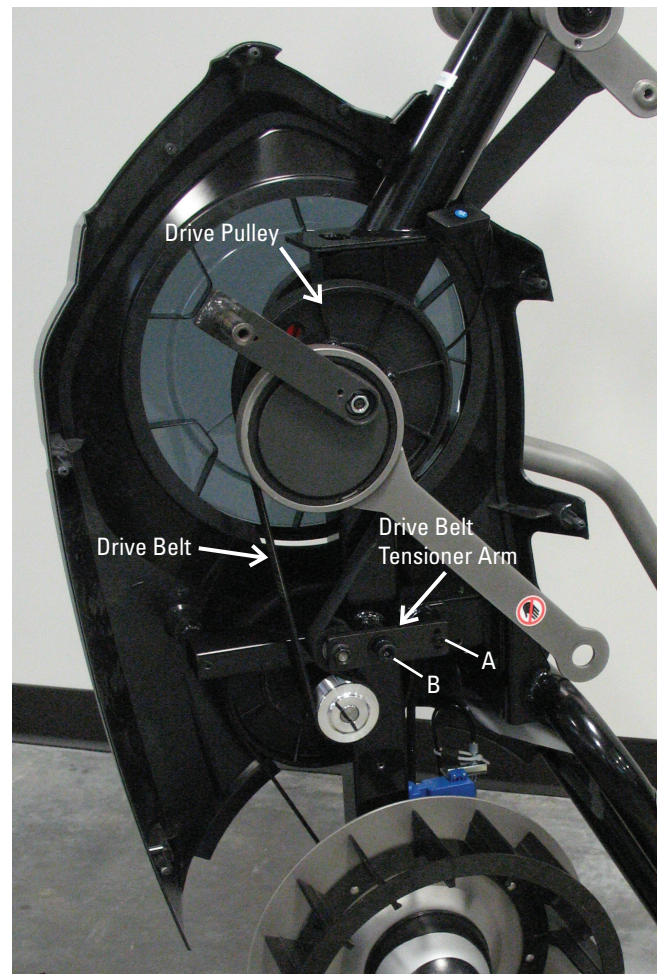

32. Installation is the reverse procedure excluding steps with the Crank Puller. The Crank Puller is not required for re-assembly.

Note: When replacing the Crank Arm be sure the Right and Left Crank Arms are oriented inline and opposite each other.

The Crank Nut should be tightened to a torque value of 29-32.5 ft lbs (or 350-390 in lbs).

33. Final Inspection

Inspect your machine to ensure that all hardware is tight and components are properly assembled.



Do not use until the machine has been fully assembled and inspected for correct performance in accordance with the Owner's Manual.

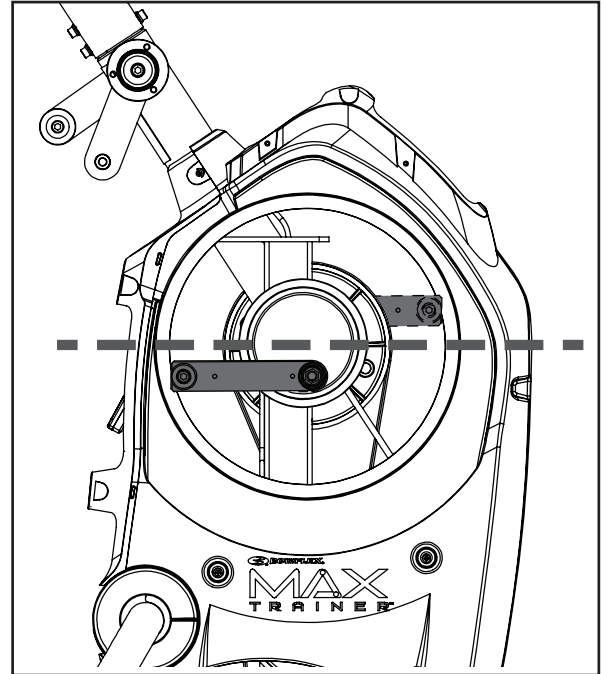

NOTICE: This document provides instructions for the replacement of the Hardware that attaches the Drive Pulley on the Bowflex™ Max Total™ machine / Max Total™ 16/40 / Max Trainer™ M9.

If you need assistance, please contact Customer Service (if purchased in US/Canada) or your local distributor (if purchased outside US/Canada). To find your local distributor, go to: www.nautilusinternational.com

This icon means a potentially hazardous situation which, if not avoided, could result in death or serious injury. Read and understand all Warnings on this machine.

Nautilus, Inc., www.NautilusInc.com, 5415 Centerpoint Parkway, Groveport, OH 43125 U.S.A. - Customer Service: North America (800) 605-3369, csnls@nautilus.com | outside U.S. www.nautilusinternational.com | Printed in China | © 2020 Nautilus, Inc. | Bowflex, the B logo, Max Total, and Max Trainer are trademarks owned or licensed by Nautilus, Inc., registered or otherwise protected by common law in the United States and other nations. | **ORIGINAL DOCUMENT - ENGLISH VERSION ONLY**

Important Safety Instructions - Before servicing or using this equipment, obey the following warnings:

This icon means a potentially hazardous situation which, if not avoided, could result in death or serious injury. Read and understand all Warnings on this machine.

- Read and understand the Part Replacement Procedure before working on the machine. Failure to obey the instructions and safety warnings could cause injury to the service technician or bystanders.
- Keep bystanders, children and pets away from the product being serviced at all times.
- Make sure that the repair is done in an appropriate work space away from foot traffic and exposure to bystanders.
- Disconnect all power and allow to sit for 5 minutes before you service this machine.
- Some components of the equipment can be heavy or awkward. Enlist the service of a second person when you do maintenance steps involving these components. Do not try to do heavy or awkward steps on your own.
- If replacement parts are necessary, use only genuine Nautilus replacement parts and hardware. Failure to use genuine replacement parts can cause a risk to users, keep the machine from operating correctly and will void the warranty.
- Be sure that all warning stickers and instructional placards applied to the product stay present and in good condition when doing maintenance or replacing components. If at any time the Warning labels become loose, unreadable or dislodged, replace the labels. If purchased in US/Canada, contact Customer Service for replacement labels. If purchased outside US/Canada, contact your local distributor for them.
- Do not try to change the design or functionality of the machine being serviced as this can adversely effect user safety and will void the warranty.
- Do not use the machine until all shrouds, instructions, warning labels and correct functionality have been verified and tested for correct performance.

• SAVE THESE INSTRUCTIONS.

Tools Required (not included)

#2 Phillips screwdriver



10mm wrench

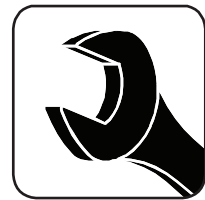

5mm hex wrench
6mm hex wrench



9/16" or 14mm Socket and Wrench



Crank Puller (non-handled,
JIS/ISO square taper
with M22x1.0 threads)

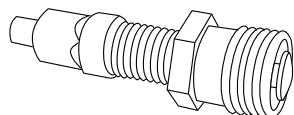

1. Unplug the AC Adapter from the wall outlet and machine.

2. Using a 5mm hex wrench, remove the indicated hardware from the Left Upper Handlebar and place it out of the work area.

Note: Be aware that the Upper Handlebar must be supported when removing the hardware.



3. Using a #2 Phillips screwdriver, remove the 4 screws (2 indicated on one side) from the Upper Shroud and remove it.



4. Remove the indicated Cap from the machine.

5. Using a 6mm hex wrench, remove the hardware exposed from below the Cap.

6. Slide the Left Leg Assembly off of the machine.



7. Using a #2 Phillips screwdriver, remove the 2 indicated screws (by ovals) from the Left Crank Cover.

8. Remove the Left Crank Cover from the machine.

9. Place a rag or protective material below the Left Connector Arm to protect the Shroud from potential scratches from the Connector Arm.

10. Using a 6mm hex wrench, remove the indicated hardware (with arrows) that connects the Left Connector Arm and the Pivot Arm.

Note: The Connector Arm will pivot downward if not lowered slowly onto the rag protecting the Shroud.

11. Using a 9/16" or 14mm socket and wrench, remove the nut from the Left Crank Assembly.

12. Adjust the Crank Puller until the end of the Bolt is flush with the Nut (as shown).

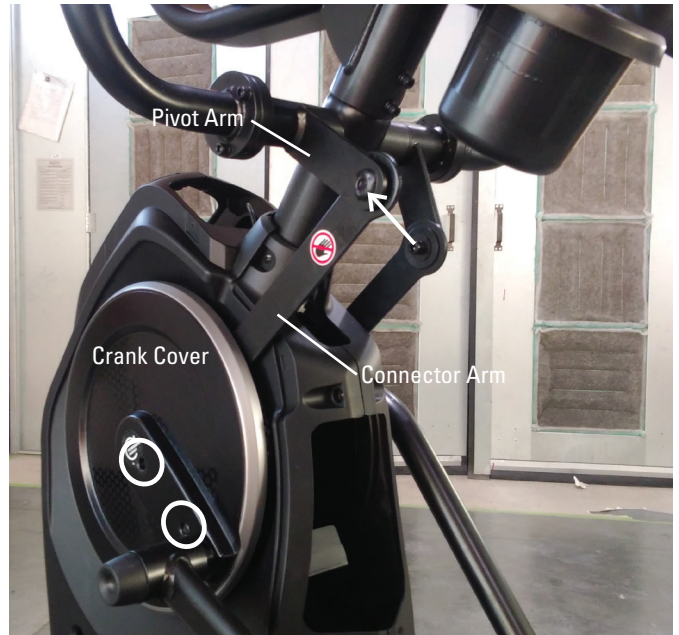

13. Carefully thread the Crank Puller into the Left Crank Arm. Be sure the Crank Puller has at least three rounds of threads inserted.

14. Using a 16mm wrench, turn the inner portion (the Bolt) of the Crank Puller clockwise. The Left Crank Arm will slide off as it is tightened.

Note: Be aware that the Left Crank Arm will be loose and will need to be supported.

15. Remove the Crank Puller from the Left Crank Arm.



16. Inspect the Drive Pulley and the screws that secure it.

* If the Drive Pulley is worn or damaged OR any of the screws have been sheared off, use the "Replace the Drive Pulley" Procedure for replacement instructions.

* If one or more screws are currently missing, skip to Step 21.

* If all four screws are present, use an appropriately sized hex wrench to remove one of the four screws that attach the Drive Pulley.

17. Using a 5mm hex wrench, attach one of the replacement screws and lock washers provided in the kit. Fully tighten the screw. Once fully tightened, secure the screw with one of the provided securing nuts using a 10mm wrench.

18. Rotate the Drive Pulley to replace each screw with the provided hardware (screw and securing nut) one at a time.

Note: The kit contains a replacement Drive Pulley. This part will not be used if this procedure is performed correctly.

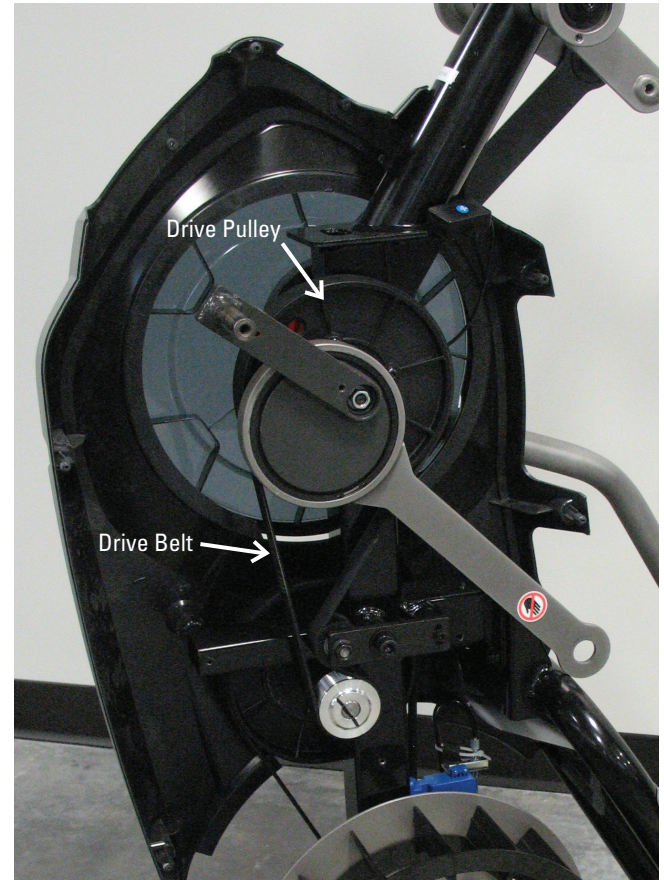

19. Installation is the reverse procedure excluding steps with the Crank Puller. The Crank Puller is not required for re-assembly.

Note: When replacing the Crank Arm be sure the Right and Left Crank Arms are oriented inline and opposite each other.
The Crank Nut should be tightened to a torque value of 29-32.5 ft lbs (or 350-390 in lbs).

20. Final Inspection

Inspect your machine to ensure that all hardware is tight and components are properly assembled.



Do not use until the machine has been fully assembled and inspected for correct performance in accordance with the Owner's Manual.

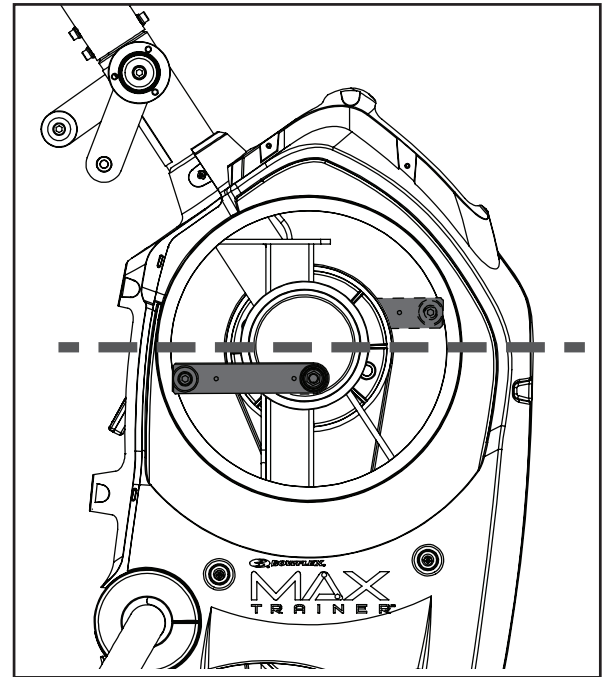

NOTICE: This document provides instructions for the replacement of the Fan Assembly on the Bowflex™ Max Total™ machine / Max Total™ 16/40 / Max Trainer™ M9.

If you need assistance, please contact Customer Service (if purchased in US/Canada) or your local distributor (if purchased outside US/Canada). To find your local distributor, go to: www.nautilusinternational.com

This icon means a potentially hazardous situation which, if not avoided, could result in death or serious injury. Read and understand all Warnings on this machine.

Nautilus, Inc., www.NautilusInc.com, 5415 Centerpoint Parkway, Groveport, OH 43125 U.S.A. - Customer Service: North America (800) 605-3369, csnls@nautilus.com | outside U.S. www.nautilusinternational.com | Printed in China | © 2020 Nautilus, Inc. | Bowflex, the B logo, Max Total, and Max Trainer are trademarks owned or licensed by Nautilus, Inc., registered or otherwise protected by common law in the United States and other nations. | **ORIGINAL DOCUMENT - ENGLISH VERSION ONLY**

Important Safety Instructions - Before servicing or using this equipment, obey the following warnings:

This icon means a potentially hazardous situation which, if not avoided, could result in death or serious injury. Read and understand all Warnings on this machine.

- Read and understand the Part Replacement Procedure before working on the machine. Failure to obey the instructions and safety warnings could cause injury to the service technician or bystanders.
- Keep bystanders, children and pets away from the product being serviced at all times.
- Make sure that the repair is done in an appropriate work space away from foot traffic and exposure to bystanders.
- Disconnect all power and allow to sit for 5 minutes before you service this machine.
- Some components of the equipment can be heavy or awkward. Enlist the service of a second person when you do maintenance steps involving these components. Do not try to do heavy or awkward steps on your own.
- If replacement parts are necessary, use only genuine Nautilus replacement parts and hardware. Failure to use genuine replacement parts can cause a risk to users, keep the machine from operating correctly and will void the warranty.
- Be sure that all warning stickers and instructional placards applied to the product stay present and in good condition when doing maintenance or replacing components. If at any time the Warning labels become loose, unreadable or dislodged, replace the labels. If purchased in US/Canada, contact Customer Service for replacement labels. If purchased outside US/Canada, contact your local distributor for them.
- Do not try to change the design or functionality of the machine being serviced as this can adversely effect user safety and will void the warranty.
- Do not use the machine until all shrouds, instructions, warning labels and correct functionality have been verified and tested for correct performance.

• SAVE THESE INSTRUCTIONS.

Tools Required (not included)

#2 Phillips screwdriver



5mm hex wrench



Standard Screwdriver



1. Unplug the AC Adapter from the wall outlet and machine.

2. Remove the Right and Left Stabilizer Shrouds from the machine.

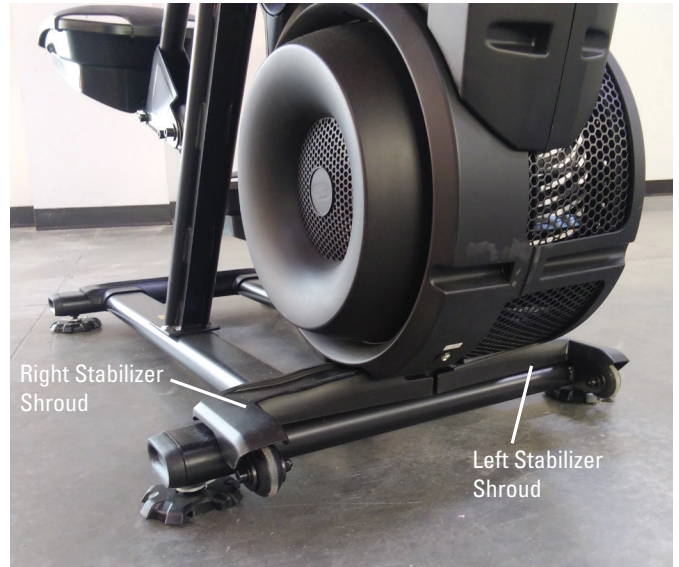

3. Using a #2 Phillips screwdriver, remove the indicated (by ovals) screws and only loosen the lowest indicated screw (arrow) from the Right Fan Cover.

4. The Right Fan Cover has a tab that needs to be pushed upward to clear the loosened screw. While pushing up on the tab, remove the Right Fan Cover from the assembly.

Note: the Power Cable is attached to the inside of the Right Fan Cover. Be sure not to crimp the cable by placing the Right Fan Cover close to the front of the machine.

To assist with assembly, note that the upper screw is a machine screw and not a self-tapping screw.

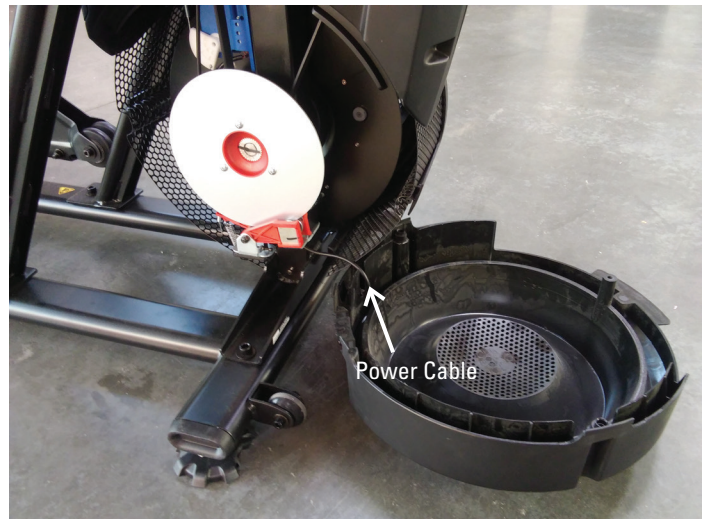
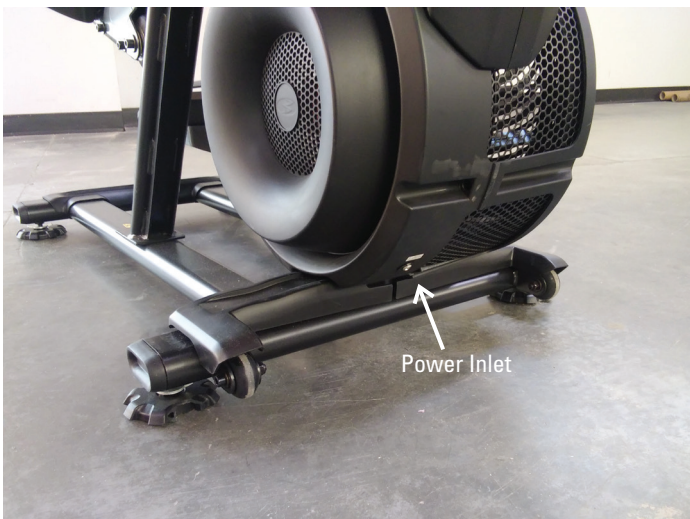
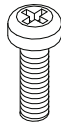

5. Using a #2 Phillips screwdriver, remove the indicated (by oval) screw and only loosen the lowest indicated screw (arrow) from the Left Fan Cover.

6. The Left Fan Cover Assembly has a tab that needs to be pushed upward to clear the loosened screw. While pushing up on the tab, remove the Left Fan Cover Assembly.

7. Remove the Left Fan Cover Assembly from the machine. Be sure to note how the fan screens are set into the Left Fan Cover to assist with the replacement procedure.



Note: Your machine may not match the images provided exactly.

8. Remove the Cone from the Fan Assembly. There are 4 clips that attach the Cone that can be accessed behind the Fan Assembly. Using a small standard screwdriver, gently release the clips.

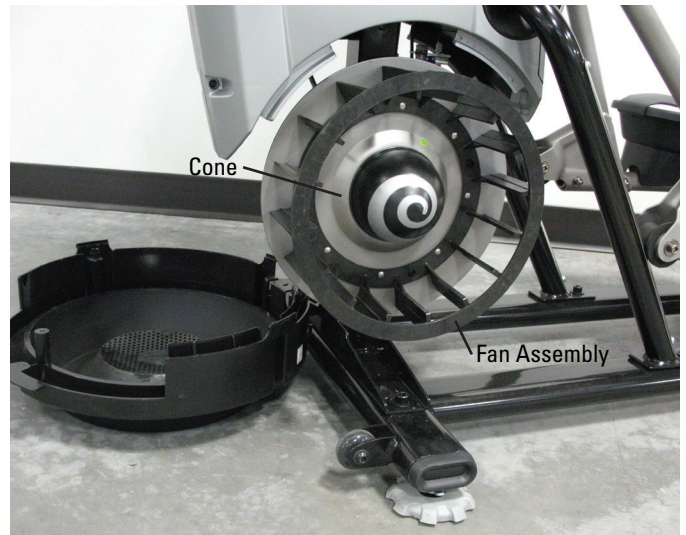

9. Using a 5mm hex wrench, remove the 4 screws from the Fan Assembly. Be sure to support the Fan Assembly when removing hardware.

10. Installation is the reverse procedure.

11. Final Inspection
Inspect your machine to ensure that all hardware is tight and components are properly assembled.

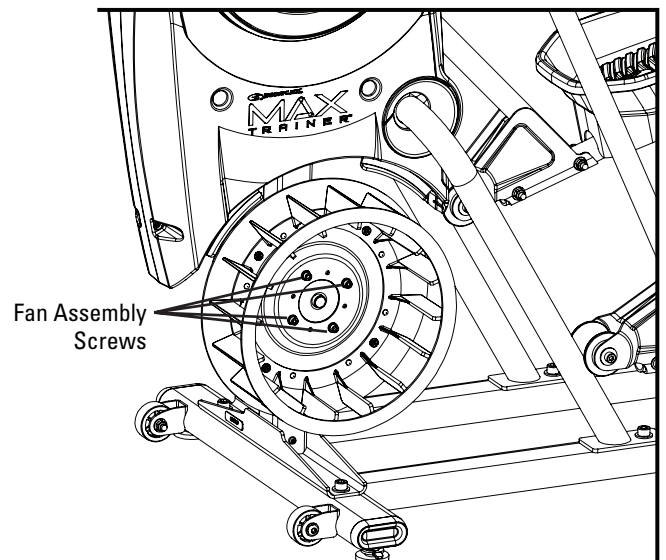

Do not use until the machine has been fully assembled and inspected for correct performance in accordance with the Owner's Manual.

NOTICE: This document provides instructions for the replacement of the Fan Belt on the Bowflex™ Max Total™ machine / Max Total™ 16/40 / Max Trainer™ M9.

If you need assistance, please contact Customer Service (if purchased in US/Canada) or your local distributor (if purchased outside US/Canada). To find your local distributor, go to: www.nautilusinternational.com

This icon means a potentially hazardous situation which, if not avoided, could result in death or serious injury. Read and understand all Warnings on this machine.

Nautilus, Inc., www.NautilusInc.com, 5415 Centerpoint Parkway, Groveport, OH 43125 U.S.A. - Customer Service: North America (800) 605-3369, csnls@nautilus.com | outside U.S. www.nautilusinternational.com | Printed in China | © 2019 Nautilus, Inc. | Bowflex, the B logo, Max Total, and Max Trainer are trademarks owned or licensed by Nautilus, Inc., registered or otherwise protected by common law in the United States and other nations. | **ORIGINAL DOCUMENT - ENGLISH VERSION ONLY**

Important Safety Instructions - Before servicing or using this equipment, obey the following warnings:

This icon means a potentially hazardous situation which, if not avoided, could result in death or serious injury. Read and understand all Warnings on this machine.

- Read and understand the Part Replacement Procedure before working on the machine. Failure to obey the instructions and safety warnings could cause injury to the service technician or bystanders.
- Keep bystanders, children and pets away from the product being serviced at all times.
- Make sure that the repair is done in an appropriate work space away from foot traffic and exposure to bystanders.
- Disconnect all power and allow to sit for 5 minutes before you service this machine.
- Some components of the equipment can be heavy or awkward. Enlist the service of a second person when you do maintenance steps involving these components. Do not try to do heavy or awkward steps on your own.
- If replacement parts are necessary, use only genuine Nautilus replacement parts and hardware. Failure to use genuine replacement parts can cause a risk to users, keep the machine from operating correctly and will void the warranty.
- Be sure that all warning stickers and instructional placards applied to the product stay present and in good condition when doing maintenance or replacing components. If at any time the Warning labels become loose, unreadable or dislodged, replace the labels. If purchased in US/Canada, contact Customer Service for replacement labels. If purchased outside US/Canada, contact your local distributor for them.
- Do not try to change the design or functionality of the machine being serviced as this can adversely effect user safety and will void the warranty.
- Do not use the machine until all shrouds, instructions, warning labels and correct functionality have been verified and tested for correct performance.

• SAVE THESE INSTRUCTIONS.

Tools Required (not included)

#2 Phillips screwdriver

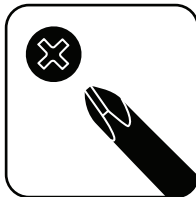

6mm hex wrench



#2 Standard screwdriver



Wire Cutter

Heavy Duty Zip-Tie



Note: Your machine may not match the images provided exactly.

1. Unplug the AC Adapter from the wall outlet and machine.

2. Using a 6mm hex wrench, remove the indicated hardware from the Right Upper Handlebar and place it out of the work area.

Note: Be aware that the Right Upper Handlebar must be supported when removing the hardware.



3. Using a #2 Phillips screwdriver, remove the 4 screws (2 indicated on one side) from the Upper Shroud and remove it.



4. Remove the Right and Left Stabilizer Shrouds from the machine (if equipped).

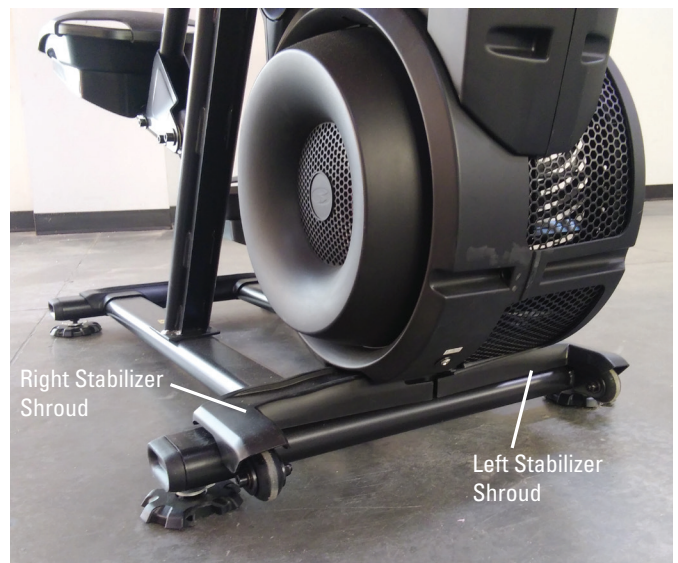

5. Using a #2 Phillips screwdriver, remove the indicated (by ovals) screws and only loosen the lowest indicated screw (arrow) from the Right Fan Cover.

6. The Right Fan Cover has a tab that needs to be pushed upward to clear the loosened screw. While pushing up on the tab, remove the Right Fan Cover from the assembly.

Note: The Power Cable is attached to the inside of the Right Fan Cover. Be sure not to crimp the cable by placing the Right Fan Cover close to the front of the machine.

To assist with assembly, note that the upper screw is a machine screw and not a self-tapping screw.

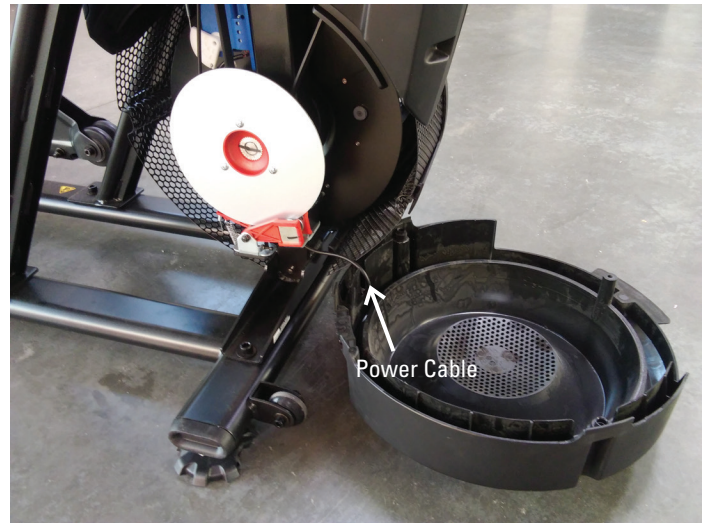
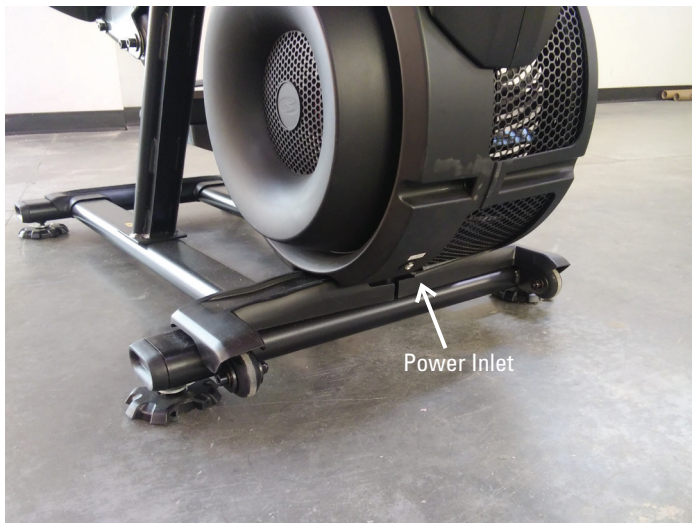
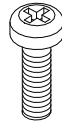

7. Remove the indicated Cap from the machine.

8. Using a 6mm hex wrench, remove the hardware exposed from below the Cap.

9. Slide the Right Leg Assembly off of the machine.



10. Using a #2 Phillips screwdriver, remove the indicated screw (by arrow) from the Rear Shroud.

11. Carefully remove the Rear Shroud from the machine. Place a standard screwdriver behind and near the middle of the Rear Shroud and gently pry until it releases. Then move the screwdriver to the bottom and gently pry until the Rear Shroud comes off.

12. Remove the indicated Caps from the machine.



13. Using a #2 Phillips screwdriver, remove the indicated (by oval) screw and only loosen the lowest indicated screw (arrow) from the Left Fan Cover.

14. The Left Fan Cover Assembly has a tab that needs to be pushed upward to clear the loosened screw. While pushing up on the tab, remove the Left Fan Cover Assembly.



15. Using a #2 Phillips screwdriver, remove the 2 indicated screws from the Right Crank Cover.

16. Remove the Right Crank Cover from the machine.

Note: The Right Crank Cover screws may have been over-tightened when installed. Try not to strip the screws when removing them.

17. Place a rag or protective material below the Right Connector Arm to protect the Shrouds from potential scratches from the Connector Arms.

18. Using a 6mm hex wrench, remove the hardware that connects the Right Connector Arm and the Pivot Arm.

Note: The Connector Arm will pivot downward if not lowered slowly onto the rag protecting the Shroud.

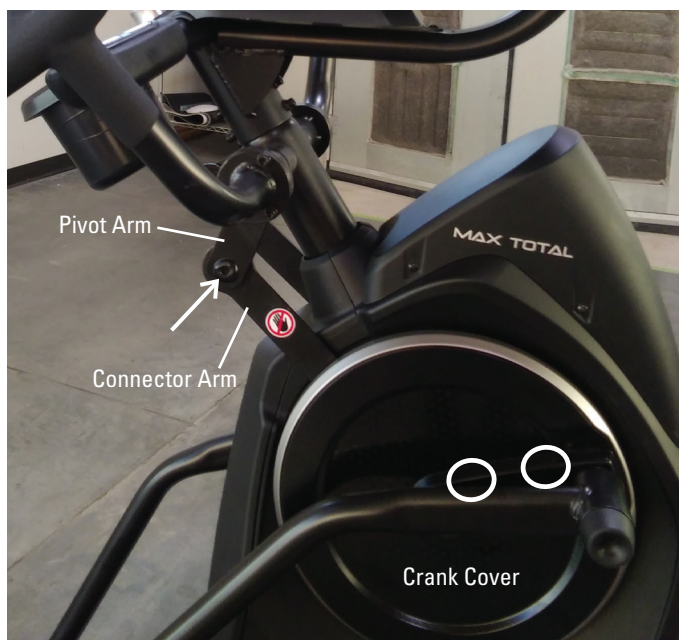

19. Using a #2 Phillips screwdriver, remove the screws from the Right Shroud (3 screws on the Right Shroud). Remove the upper screws labeled ' * ' last.

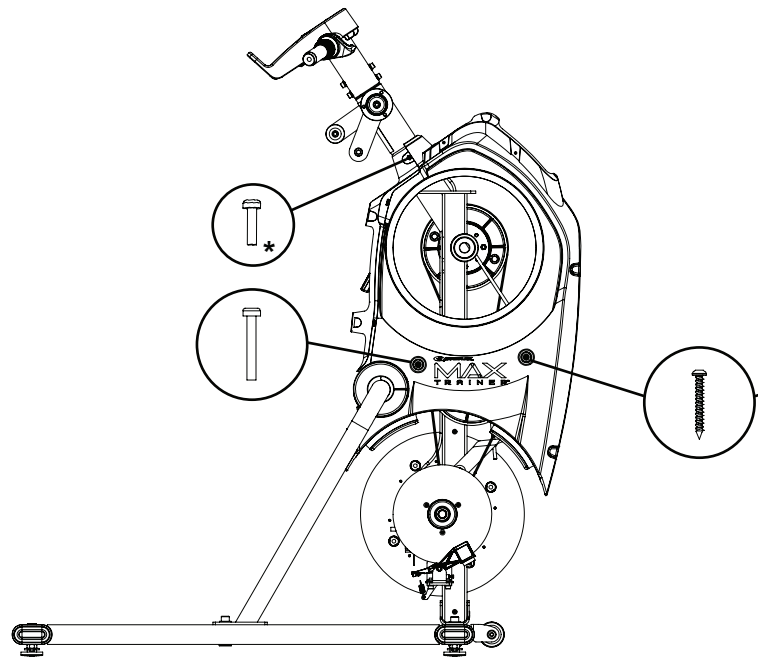

Right Side

20. Using a #2 Phillips screwdriver, remove the 3 screws (indicated by arrows) from the Brake Disc.

21. Carefully remove the Brake Disc from the machine exposing the lower Fan Belt.

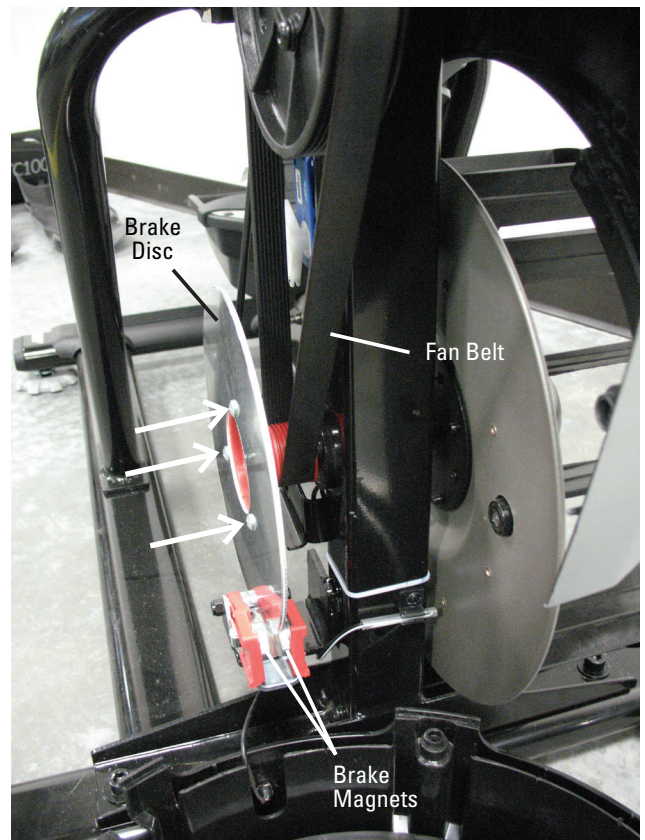

22. Turn the Fan Pulley while forcing the Fan Belt to the outside. Belt will come off of the Fan Pulley.

 **Keep fingers out of any pinch opportunities when removing the Fan Belt.**

23. Loop the new Fan Belt around the lower Pulley and start it on the face of the Fan Pulley.

24. Be sure the Fan Belt is centered on both pulleys.



25. Secure the Fan Belt to the Fan Pulley with a Heavy Duty Zip-Tie. Be sure to attach the Zip-Tie where the Fan Belt is fully in contact with the Fan Pulley.

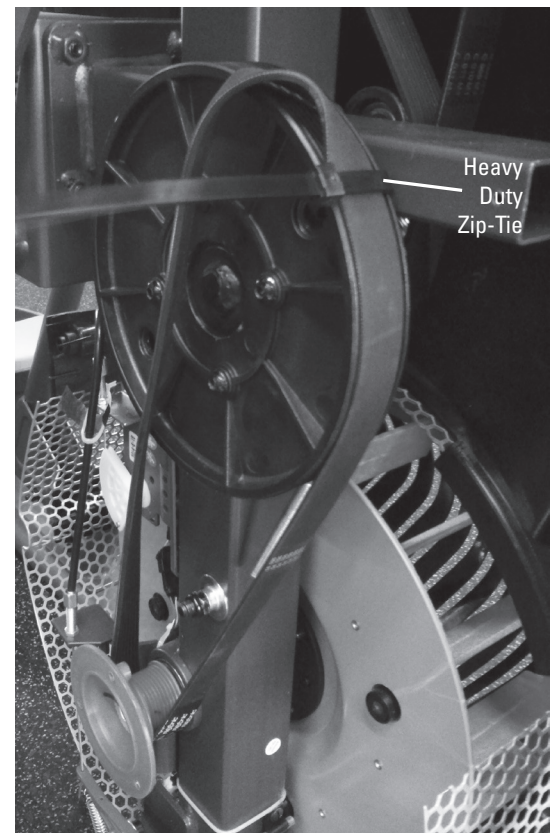

26. Grasp the Fan Pulley where the Fan Belt is engaged on it, and forcibly rotate the Fan Pulley until the Fan Belt is fully engaged.

 **Keep fingers out of any pinch opportunities when rotating the Fan Pulley.**



27. Cut the Zip-Tie without damaging the new Fan Belt or Fan Pulley.

28. Installation is the reverse procedure.

29. Final Inspection

Inspect your machine to ensure that all hardware is tight and components are properly assembled.

 **Do not use until the machine has been fully assembled and inspected for correct performance in accordance with the Owner's Manual.**

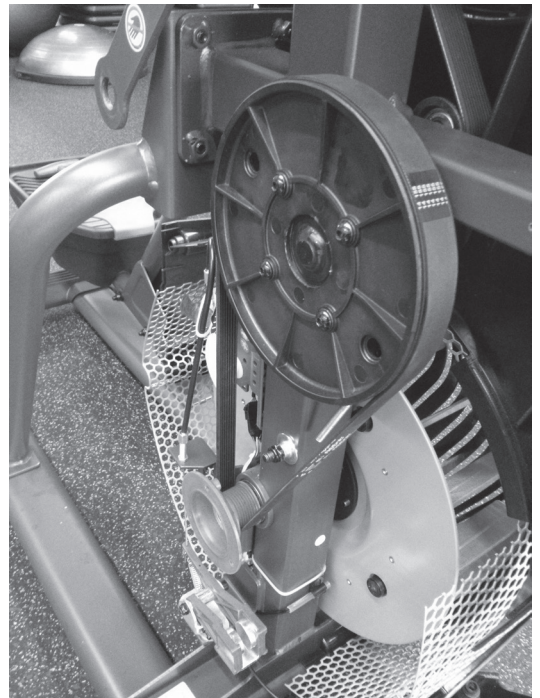

NOTICE: This document provides instructions for the replacement of the Fan Pulley on the Bowflex™ Max Total™ machine / Max Total™ 16/40 / Max Trainer™ M9.

If you need assistance, please contact Customer Service (if purchased in US/Canada) or your local distributor (if purchased outside US/Canada). To find your local distributor, go to: www.nautilusinternational.com

This icon means a potentially hazardous situation which, if not avoided, could result in death or serious injury. Read and understand all Warnings on this machine.

Nautilus, Inc., www.NautilusInc.com, 5415 Centerpoint Parkway, Groveport, OH 43125 U.S.A. - Customer Service: North America (800) 605-3369, csnls@nautilus.com | outside U.S. www.nautilusinternational.com | Printed in China | © 2020 Nautilus, Inc. | Bowflex, the B logo, Max Total, and Max Trainer are trademarks owned or licensed by Nautilus, Inc., registered or otherwise protected by common law in the United States and other nations. | ORIGINAL DOCUMENT - ENGLISH VERSION ONLY

Important Safety Instructions - Before servicing or using this equipment, obey the following warnings:

This icon means a potentially hazardous situation which, if not avoided, could result in death or serious injury. Read and understand all Warnings on this machine.

- Read and understand the Part Replacement Procedure before working on the machine. Failure to obey the instructions and safety warnings could cause injury to the service technician or bystanders.
- Keep bystanders, children and pets away from the product being serviced at all times.
- Make sure that the repair is done in an appropriate work space away from foot traffic and exposure to bystanders.
- Disconnect all power and allow to sit for 5 minutes before you service this machine.
- Some components of the equipment can be heavy or awkward. Enlist the service of a second person when you do maintenance steps involving these components. Do not try to do heavy or awkward steps on your own.
- If replacement parts are necessary, use only genuine Nautilus replacement parts and hardware. Failure to use genuine replacement parts can cause a risk to users, keep the machine from operating correctly and will void the warranty.
- Be sure that all warning stickers and instructional placards applied to the product stay present and in good condition when doing maintenance or replacing components. If at any time the Warning labels become loose, unreadable or dislodged, replace the labels. If purchased in US/Canada, contact Customer Service for replacement labels. If purchased outside US/Canada, contact your local distributor for them.
- Do not try to change the design or functionality of the machine being serviced as this can adversely effect user safety and will void the warranty.
- Do not use the machine until all shrouds, instructions, warning labels and correct functionality have been verified and tested for correct performance.

• SAVE THESE INSTRUCTIONS.

Tools Required (not included)

#2 Phillips screwdriver

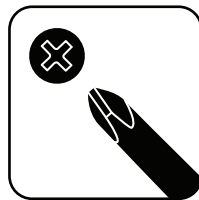

10mm wrench
16mm wrench

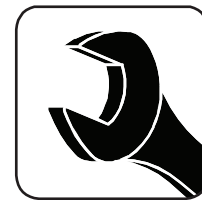

9/16" or 14mm Socket and Wrench



5mm hex wrench
6mm hex wrench

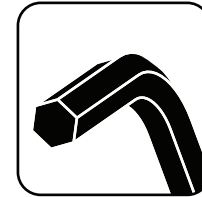

Crank Puller (non-handled,
JIS/ISO square taper
with M22x1.0 threads)

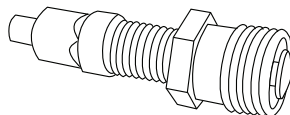

Wire Cutter

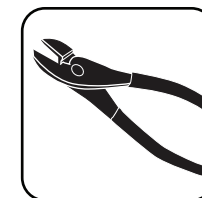

Heavy Duty Zip-Tie



1. Unplug the AC Adapter from the wall outlet and machine.

2. Using a 5mm hex wrench, remove the indicated hardware from the Left Upper Handlebar and place it out of the work area.

Note: Be aware that the Right Upper Handlebar must be supported when removing the hardware.



3. Using a #2 Phillips screwdriver, remove the 4 screws (2 indicated on one side) from the Upper Shroud.



4. Remove the Right and Left Stabilizer Shrouds from the machine.

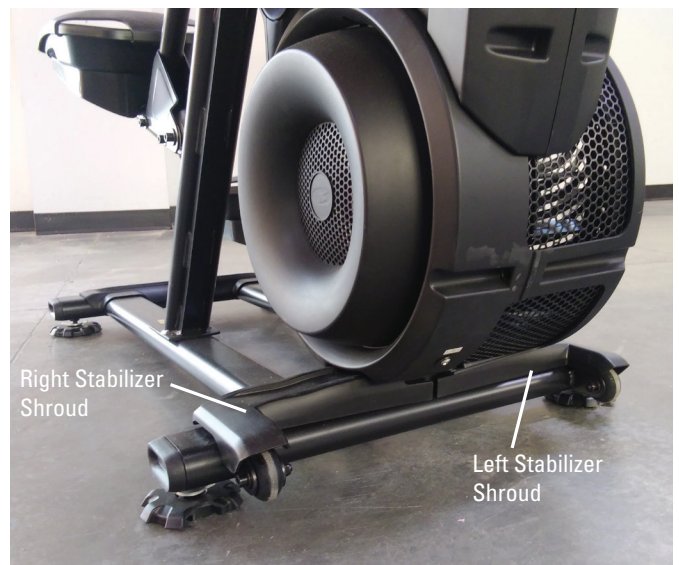

5. Using a #2 Phillips screwdriver, remove the indicated (by ovals) screws and only loosen the lowest indicated screw (arrow) from the Right Fan Cover.

6. The Right Fan Cover has a tab that needs to be pushed upward to clear the loosened screw. While pushing up on the tab, remove the Right Fan Cover from the assembly.

Note: the Power Cable is attached to the inside of the Right Fan Cover. Be sure not to crimp the cable by placing the Right Fan Cover close to the front of the machine.

To assist with assembly, note that the upper screw is a machine screw and not a self-tapping screw.

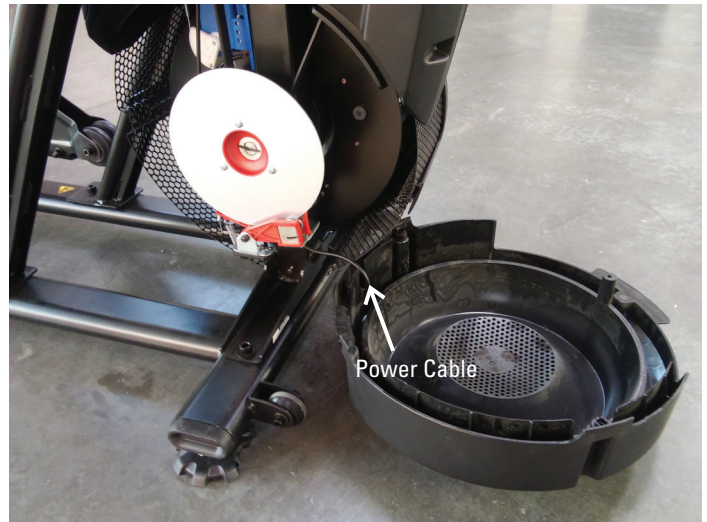
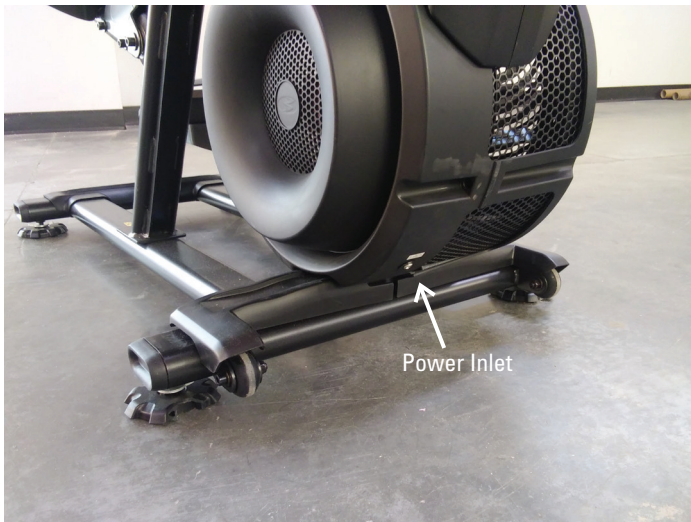
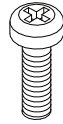

7. Remove the indicated Cap from the machine.

8. Using a 6mm hex wrench, remove the hardware exposed from below the Cap.

9. Slide the Right Leg Assembly off of the machine.



10. Using a #2 Phillips screwdriver, remove the indicated screw from the Rear Shroud.

11. Carefully remove the Rear Shroud from the machine. Place a standard screwdriver behind and near the middle of the Rear Shroud and gently pry until it releases. Then move the screwdriver to the bottom and gently pry until the Rear Shroud comes off.

12. Remove the indicated Caps from the machine.



13. Using a #2 Phillips screwdriver, remove the indicated (by oval) screw and only loosen the lowest indicated screw (arrow) from the Left Fan Cover.

14. The Left Fan Cover Assembly has a tab that needs to be pushed upward to clear the loosened screw. While pushing up on the tab, remove the Left Fan Cover Assembly.



15. Using a #2 Phillips screwdriver, remove the 2 indicated screws from the Right Crank Cover.

16. Remove the Right Crank Cover from the machine.

17. Place a rag or protective material below the Right Connector Arm to protect the Shrouds from potential scratches from the Connector Arms.

18. Using a 6mm hex wrench, remove the hardware that connects the Right Connector Arm and the Pivot Arm.

Note: The Connector Arm will pivot downward if not lowered slowly onto the rag protecting the Shroud.

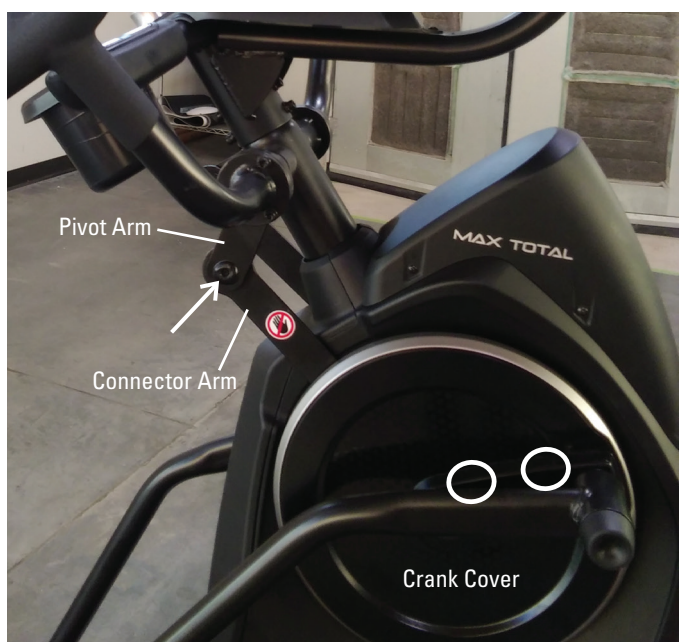

19. Using a 9/16" or 14mm socket and wrench, remove the nut from the Right Crank Assembly.



20. Adjust the Crank Puller until the end of the Bolt is inside the Nut (as shown).



21. Carefully thread the Crank Puller into the Right Crank Arm. Be sure the Crank Puller has at least three rounds of threads inserted.

22. Using a 16mm wrench, turn the inner portion (the Bolt) of the Crank Puller clockwise. The Right Crank Arm will slide off as it is tightened.

Note: Be aware that the Right Crank Arm will be loose and will need to be supported.

23. Remove the Crank Puller from the Right Crank Arm.



24. Using a #2 Phillips screwdriver, remove the screws from the Right Shroud (3 screws on the Right Shroud). Remove the upper screws labeled ' * ' last.

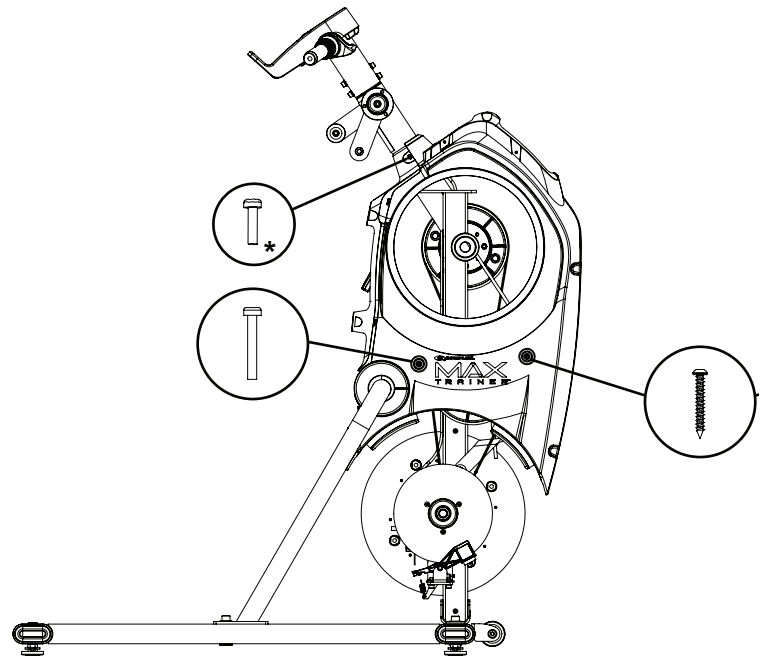

Right Side

25. Using a #2 Phillips screwdriver, remove the 3 indicated screws from the Brake Disc.

26. Carefully remove the Brake Disc from the machine exposing the lower Fan Belt.

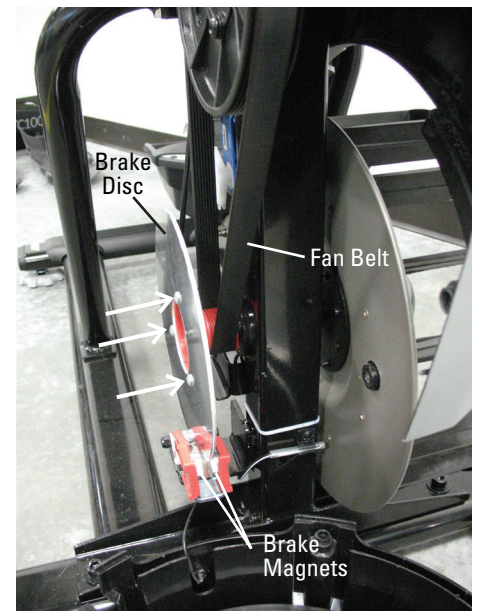

27. Turn the Fan Pulley while forcing the Fan Belt to the outside. Belt will come off of the Fan Pulley.

 **Keep fingers out of any pinch opportunities when removing the Fan Belt.**

28. Using a 10mm wrench, remove the securing nuts (if present) from the back side of the Drive Pulley.

29. Using a 5mm hex wrench, remove the four screws that attach the Fan Pulley. Be sure to support the weight of the Fan Pulley when removing hardware because it will fall.

30. Using a 5mm hex wrench, attach the new Fan Pulley to the Frame Assembly.

31. Loop the new Fan Belt around the lower Pulley and start it on the face of the Fan Pulley.

32. Be sure the Fan Belt is centered on both pulleys.

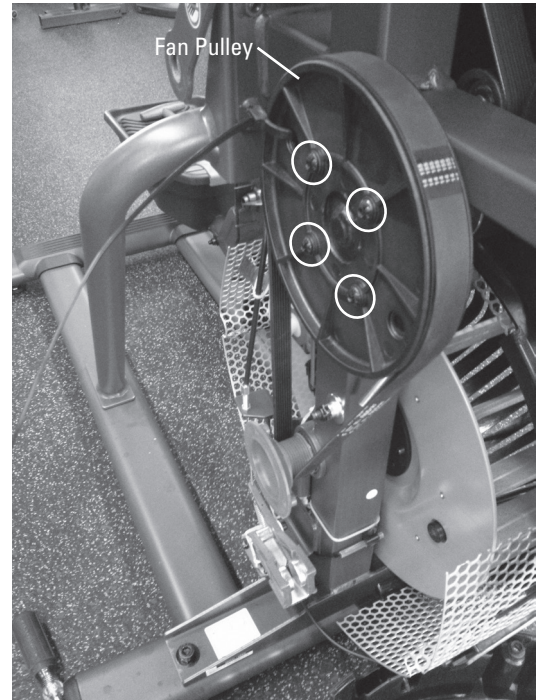

33. Secure the Fan Belt to the Fan Pulley with a Heavy Duty Zip-Tie. Be sure to attach the Zip-Tie where the Fan Belt is fully in contact with the Fan Pulley.

34. Grasp the Fan Pulley where the Fan Belt is engaged on it, and forcibly rotate the Fan Pulley until the Fan Belt is fully engaged.

 **Keep fingers out of any pinch opportunities when rotating the Fan Pulley.**

35. Cut the Zip-Tie without damaging the new Fan Belt or Fan Pulley.

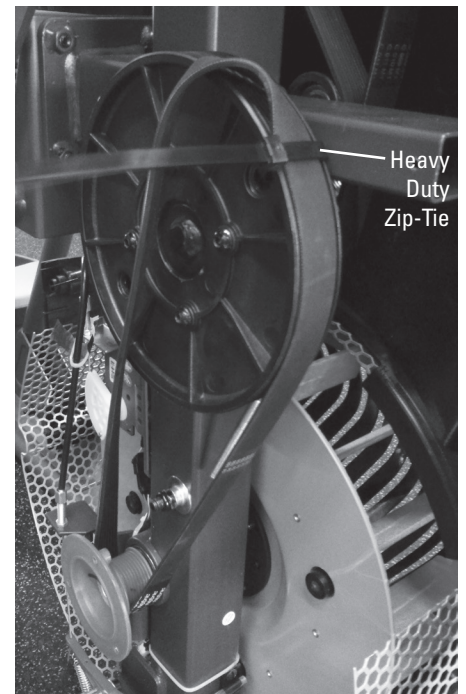

36. Installation is the reverse procedure excluding steps with the Crank Puller. The Crank Puller is not required for re-assembly.

Note: When replacing the Crank Arms, be sure the Right and Left Crank Arms are oriented inline and opposite each other.

The Crank Nuts should be tightened to a torque value of 29-32.5 ft lbs (or 350-390 in lbs).

37. Final Inspection

Inspect your machine to ensure that all hardware is tight and components are properly assembled.

 **Do not use until the machine has been fully assembled and inspected for correct performance in accordance with the Owner's Manual.**

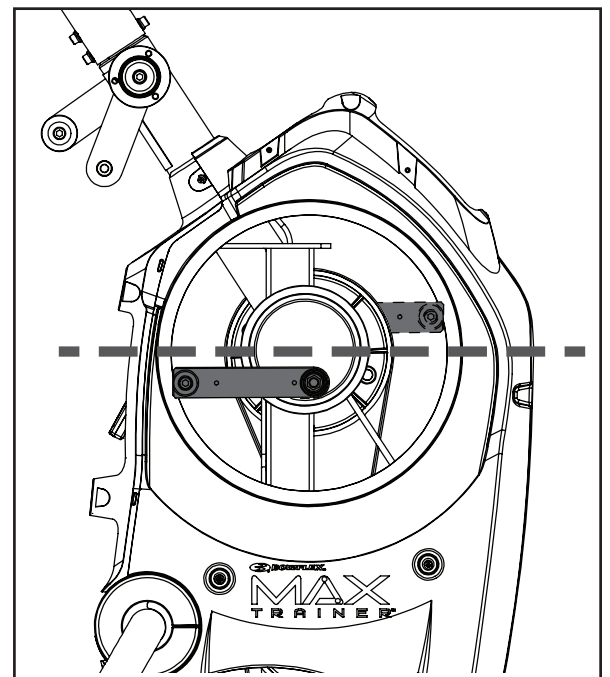

NOTICE: This document provides instructions for the replacement of the Frame Assembly on the Bowflex™ Max Total™ machine / Max Total™ 16/40 / Max Trainer™ M9.

If you need assistance, please contact Customer Service (if purchased in US/Canada) or your local distributor (if purchased outside US/Canada). To find your local distributor, go to: www.nautilusinternational.com

! This icon means a potentially hazardous situation which, if not avoided, could result in death or serious injury. Read and understand all Warnings on this machine.

Nautilus, Inc., www.NautilusInc.com, 5415 Centerpoint Parkway, Groveport, OH 43125 U.S.A. - Customer Service: North America (800) 605-3369, csnls@nautilus.com | outside U.S. www.nautilusinternational.com | Printed in China | © 2020 Nautilus, Inc. | Bowflex, the B logo, Max Total, and Max Trainer are trademarks owned or licensed by Nautilus, Inc., registered or otherwise protected by common law in the United States and other nations. | **ORIGINAL DOCUMENT - ENGLISH VERSION ONLY**

Important Safety Instructions - Before servicing or using this equipment, obey the following warnings:

! This icon means a potentially hazardous situation which, if not avoided, could result in death or serious injury. Read and understand all Warnings on this machine.

- Read and understand the Part Replacement Procedure before working on the machine. Failure to obey the instructions and safety warnings could cause injury to the service technician or bystanders.
- Keep bystanders, children and pets away from the product being serviced at all times.
- Make sure that the repair is done in an appropriate work space away from foot traffic and exposure to bystanders.
- Disconnect all power and allow to sit for 5 minutes before you service this machine.
- Some components of the equipment can be heavy or awkward. Enlist the service of a second person when you do maintenance steps involving these components. Do not try to do heavy or awkward steps on your own.
- If replacement parts are necessary, use only genuine Nautilus replacement parts and hardware. Failure to use genuine replacement parts can cause a risk to users, keep the machine from operating correctly and will void the warranty.
- Be sure that all warning stickers and instructional placards applied to the product stay present and in good condition when doing maintenance or replacing components. If at any time the Warning labels become loose, unreadable or dislodged, replace the labels. If purchased in US/Canada, contact Customer Service for replacement labels. If purchased outside US/Canada, contact your local distributor for them.
- Do not try to change the design or functionality of the machine being serviced as this can adversely effect user safety and will void the warranty.
- Do not use the machine until all shrouds, instructions, warning labels and correct functionality have been verified and tested for correct performance.

• SAVE THESE INSTRUCTIONS.

Tools Required (included)

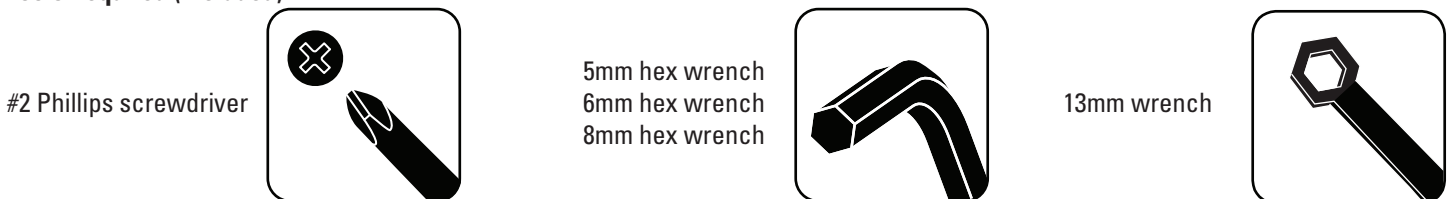

Hardware

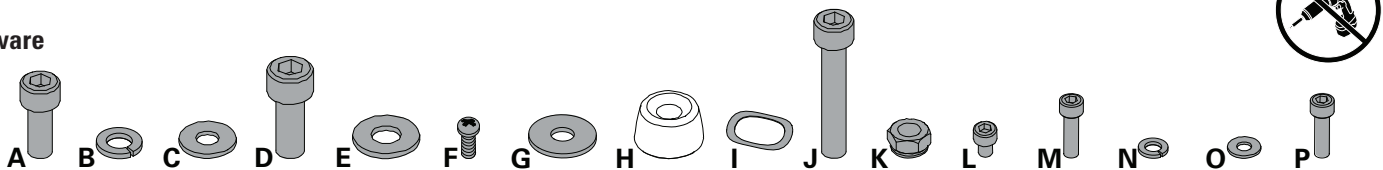

Item	Qty	Description	Item	Qty	Description
A	6	Socket Head Hex Screw, M8x1.25x20 Black	I	2	Wave Washer, 17.2x22 Black
B	6	Lock Washer, M8x14.8 Black	J	4	Socket Head Hex Screw, M8x1.0x55 Black
C	12	Washer, Flat M8x18 Black	K	4	Lock Nut, M8 Black
D	4	Socket Head Hex Screw, M10x1.5x25 Black	L	8	Socket Head Hex Screw, M6x1.0x8 Black
E	4	Washer, Flat M10x23 Black	M	4	Socket Head Hex Screw, M6x1.0x20 CL10.9 Black
F	1	Pan Phillips Screw, M5x0.8x20 Black	N	10	Lock Washer, M6x14.8 Black
G	2	Washer, Flat M8x24 Black	O	4	Washer, Flat M6x13 Black
H	2	Cap	P	6	Socket Head Hex Screw, M6x1.0x20 CL12.9 Black

Note: Replace any damaged hardware with the new hardware provided with this kit for re-assembly.

1. Unplug the AC Adapter from the wall outlet and machine.
2. Remove the Right and Left Stabilizer Shrouds from the machine.

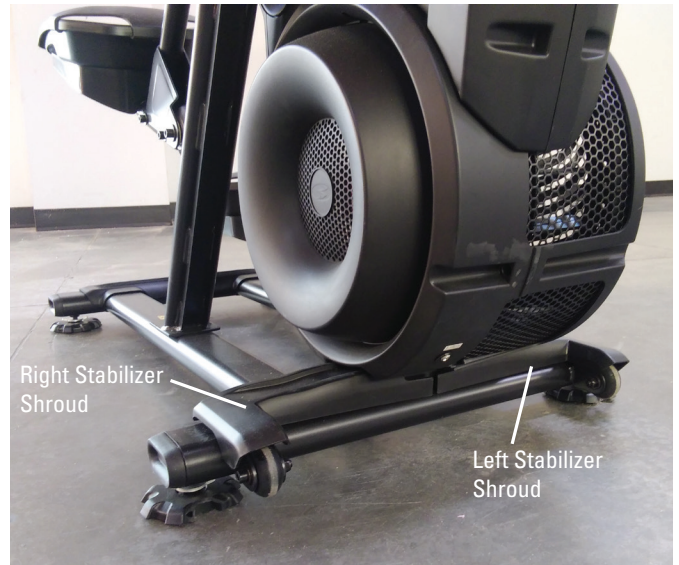

3. Using a 5mm hex wrench, remove the indicated hardware from the Right and Left Upper Handlebar and place them out of the work area.

Note: Be aware that the Right and Left Upper Handlebar must be supported when removing the hardware.

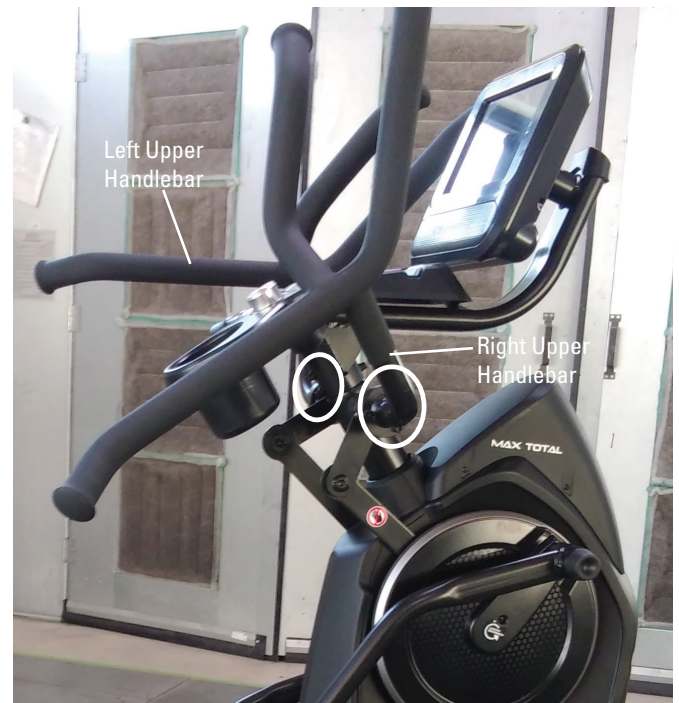

4. Using a #2 Phillips screwdriver, remove the indicated screw from the Rear Shroud.

5. Carefully remove the Rear Shroud from the machine. Place a standard screwdriver behind and near the middle of the Rear Shroud and gently pry until it releases. Then move the screwdriver to the bottom and gently pry until the Rear Shroud comes off.

6. Remove the Caps from the machine.

7. Using a 6mm hex wrench, remove the hardware exposed from below the Cap from both sides of the machine.

8. Slide the Leg Assemblies off of the machine.

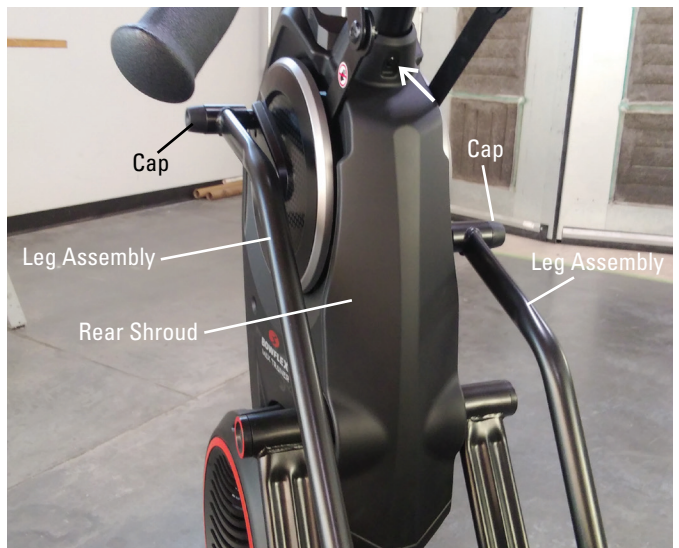

9. Using a 5mm hex wrench, remove the screws (indicated by ovals) from the Static Handlebar Assembly.



10. Carefully lift the Static Handlebar Assembly and expose the Cable Connections.

Note: Do not crimp any of the Console Cables. This step may require two people.

11. Carefully disconnect the Cables while not allowing them to fall into the Console Mast.

Note: Do not crimp any of the Console Cables.

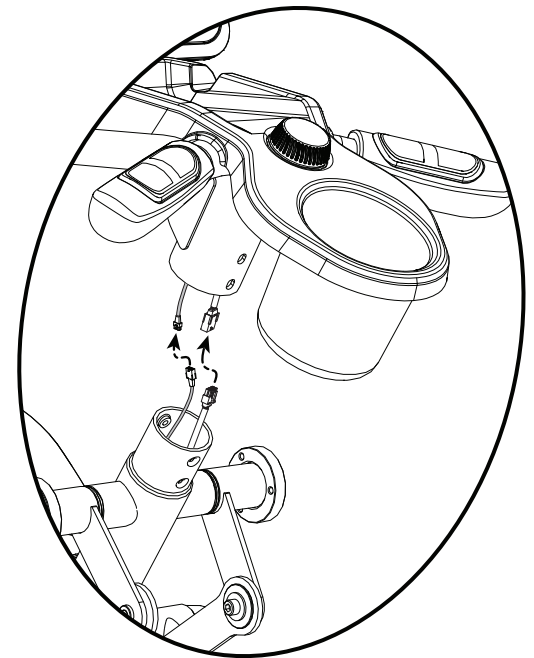
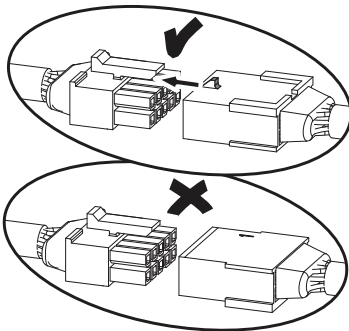

12. Using an 8mm hex wrench, remove the indicated hardware from the Rail Assembly.



13. Using a 6mm hex wrench, remove the indicated hardware from the Rail Assembly. Be prepared to support the weight of the Rail Assembly.

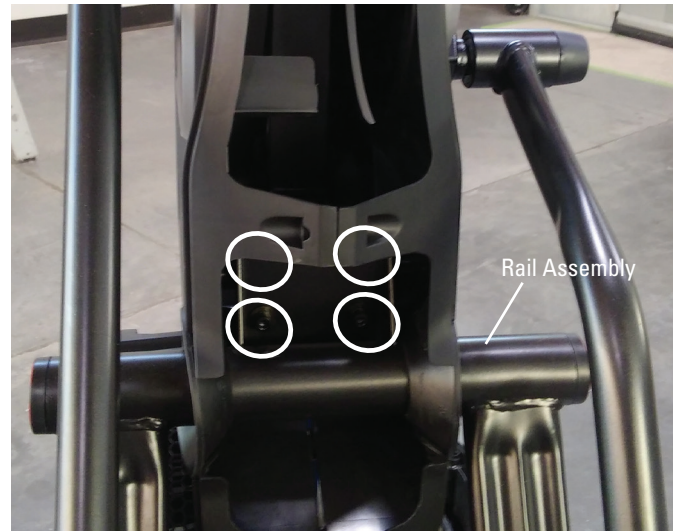

14. Using new Hardware Items C, B, and A, attach the Rail Assembly to the new Frame Assembly.

⚠ Some components of the machine can be heavy or awkward. Use a second person when doing the assembly steps involving these parts. Do not do steps that involve heavy lifting or awkward movements on your own.

NOTICE: Hand tighten hardware.

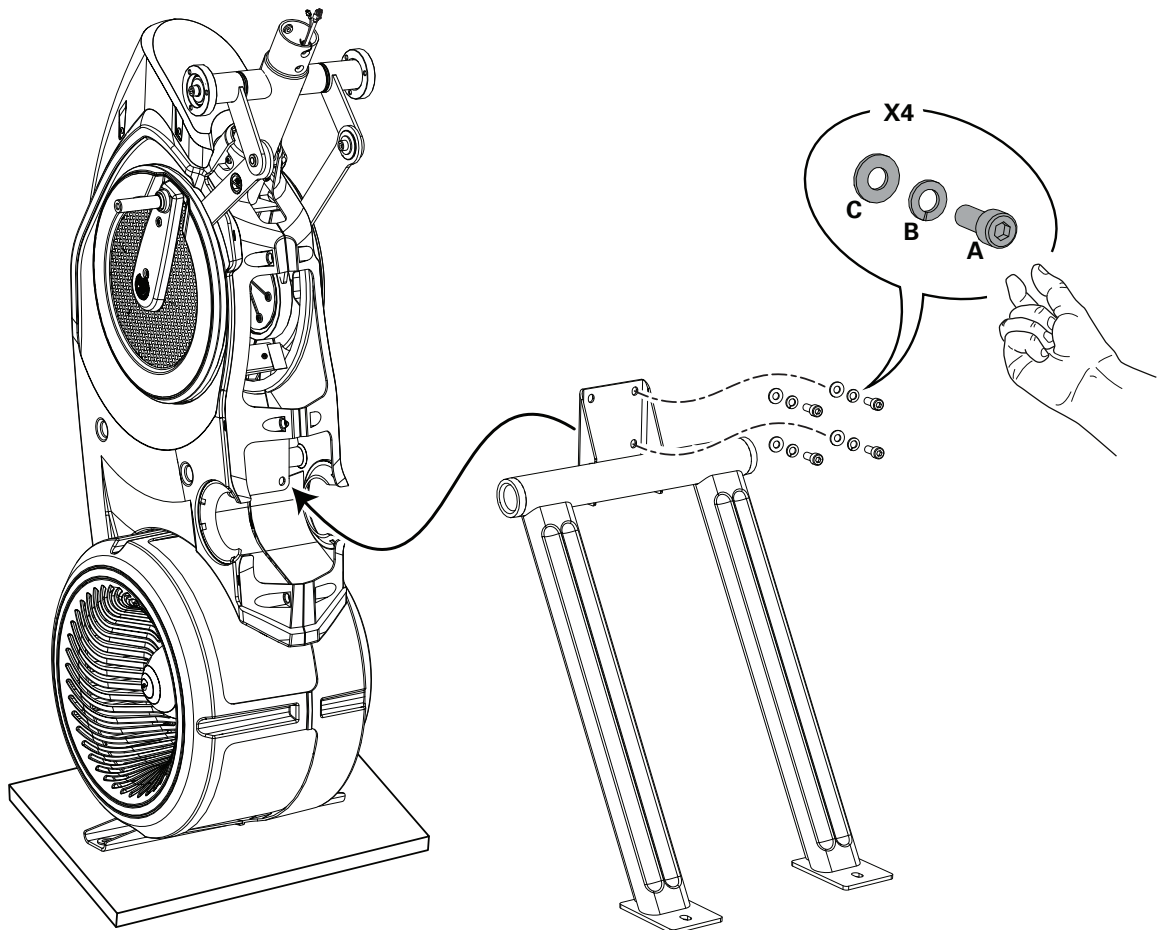

! A second person is recommended to stabilize the Frame Assembly.

15. Using an 8mm hex wrench, remove the indicated hardware from the old Frame Assembly. Be prepared to support the Frame Assembly before removing the hardware.

! The Frame Assembly may be awkward when released from the Stabilizer Assembly. Some components of the machine can be heavy or awkward. Use a second person to hold the Frame Assembly stable and upright. Do not do steps that involve heavy lifting or awkward movements on your own.

16. With the assistance of a second person, carefully lift the old Frame Assembly from the Stabilizer Assembly and place outside the assembly area. To protect your flooring, carefully place it onto its side on some cardboard or a blanket.

17. Using a 13mm wrench, remove the hardware that secures the new Frame Assembly to the shipping plate.

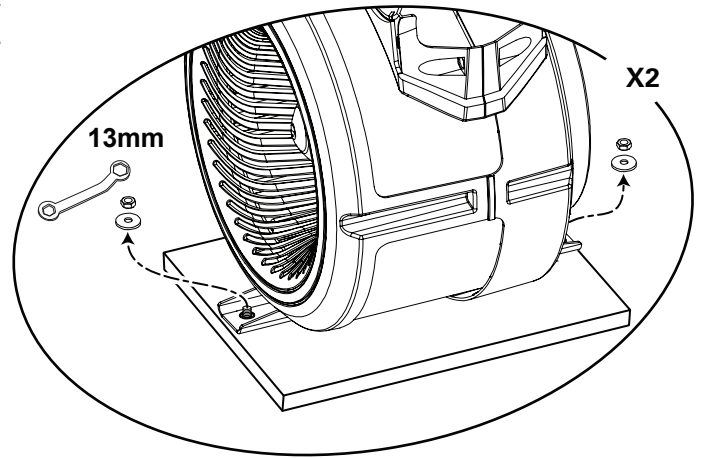

18. Carefully Lift the new Frame Assembly and Attach It to the Stabilizer Assembly

! Some components of the machine can be heavy or awkward. Use a second person when doing the assembly steps involving these parts. Do not do steps that involve heavy lifting or awkward movements on your own. Lift the Frame Assembly from the exterior of the pivot assembly as indicated below.

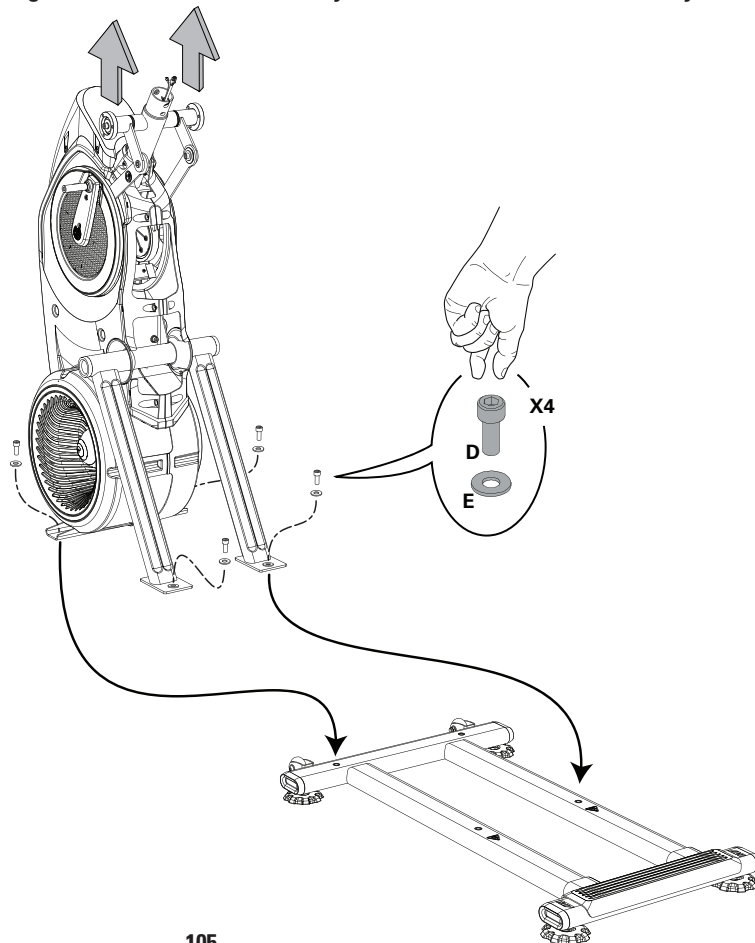

19. Fully tighten the hardware that attaches the Rail Assembly to the new Frame Assembly (from Step 13), and then the hardware just installed to the Stabilizer Assembly.

20. Using a #2 Phillips screwdriver, attach the Upper Shroud to the Frame Assembly.

21. Attach the Rear Shroud and Caps to the Frame Assembly

NOTICE: Place the inside hook of the Rear Shroud on the Frame Assembly and then pivot it up into place.

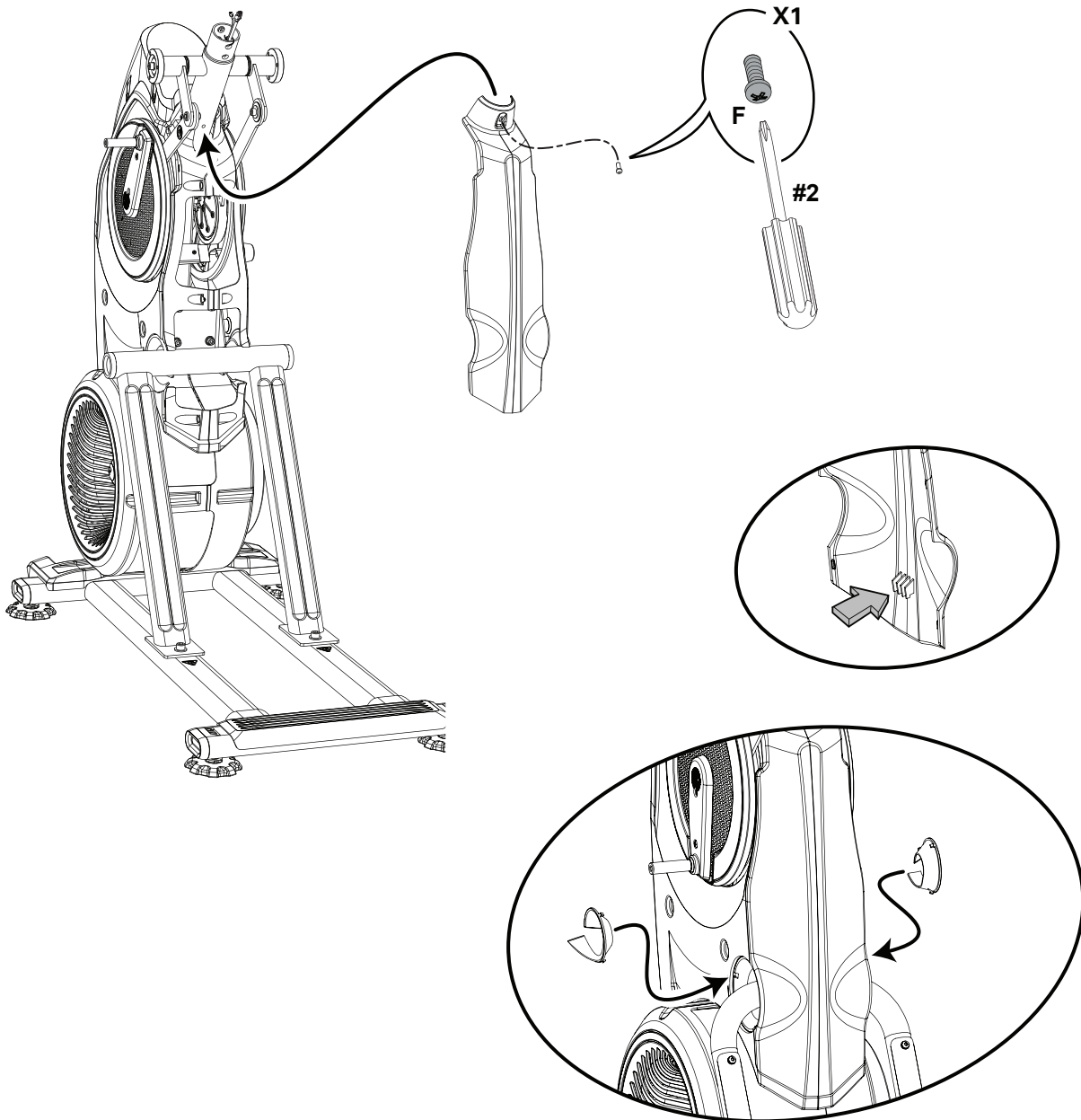

22. Attach Leg Assemblies to Frame Assembly

 Be aware that the Legs are connected and when either of these parts move the other does as well.

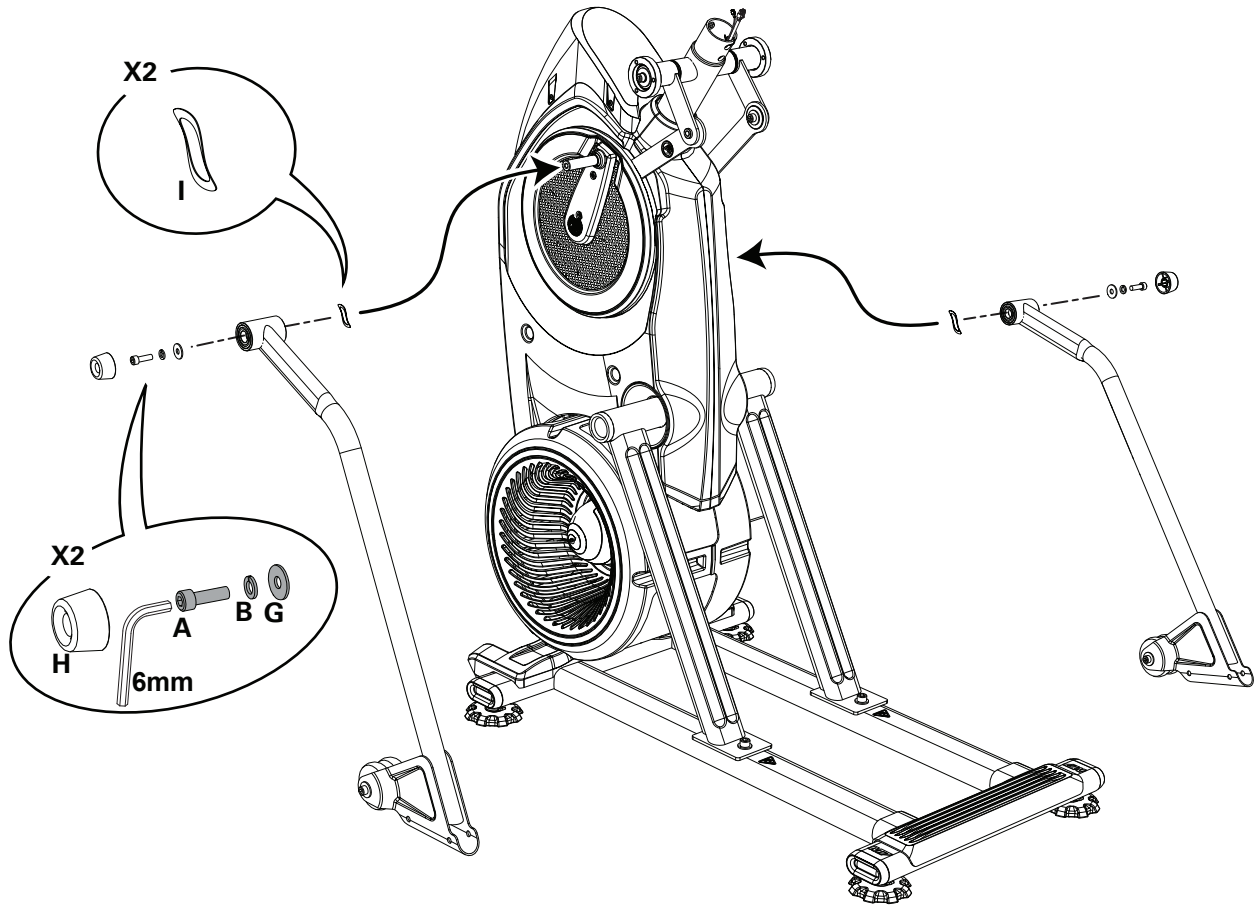

23. Connect the Static Handlebar Assembly to the Frame Assembly

Note: When attaching the Static Handlebar Assembly, do not fully tighten the hardware until all hardware has been hand tightened. Do not crimp any of the Console Cables.

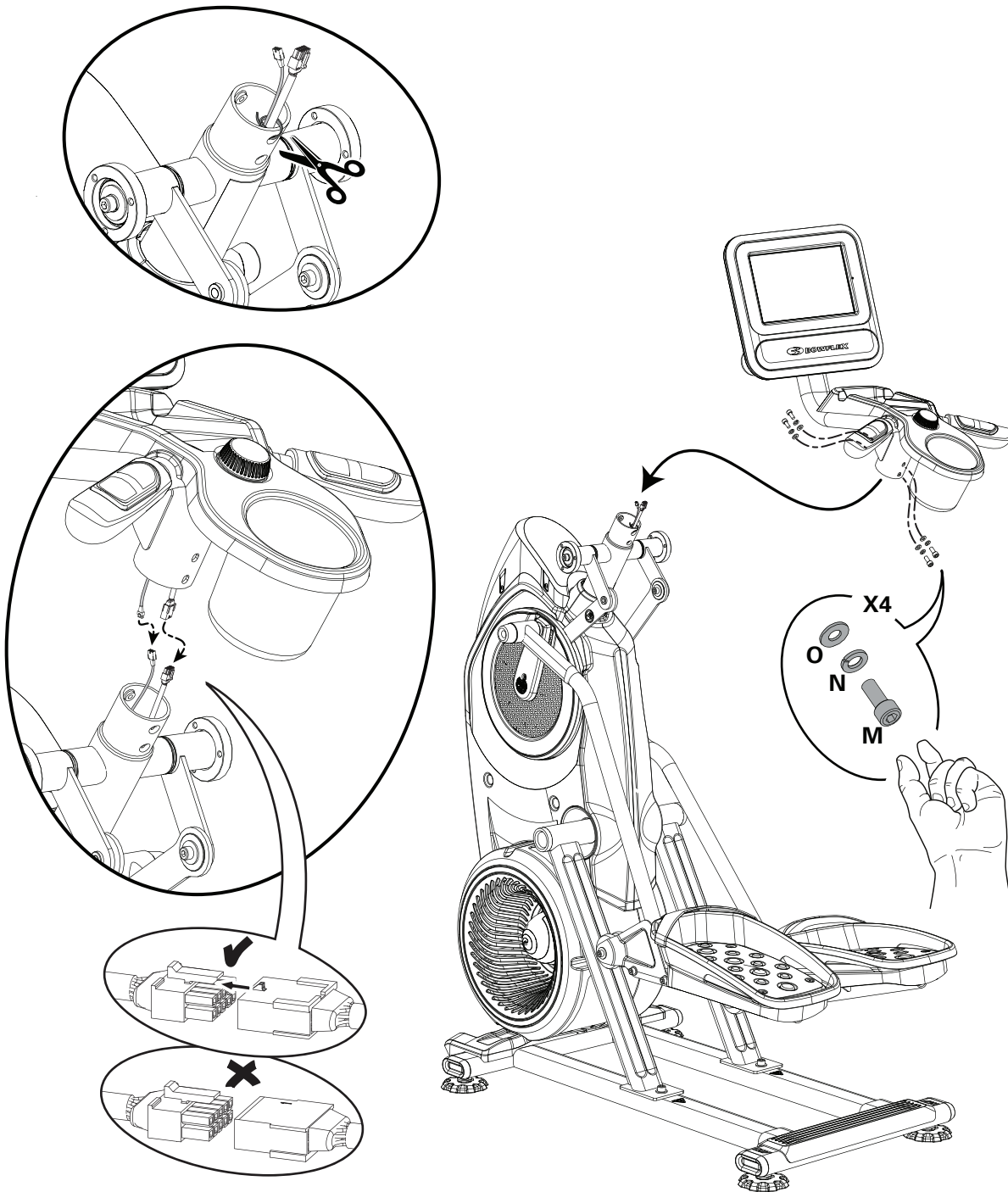

24. Attach the Upper Handlebars to Frame Assembly

! Be aware that the Pedals and the Upper Handlebars are connected and when either of these parts move the other does as well. Some components of the machine can be heavy or awkward. Use a second person when doing the assembly steps involving these parts. Do not do steps that involve heavy lifting or awkward movements on your own.

NOTICE: Be sure to attach the Upper Handlebars so they can be correctly grasped by a User when on the machine.

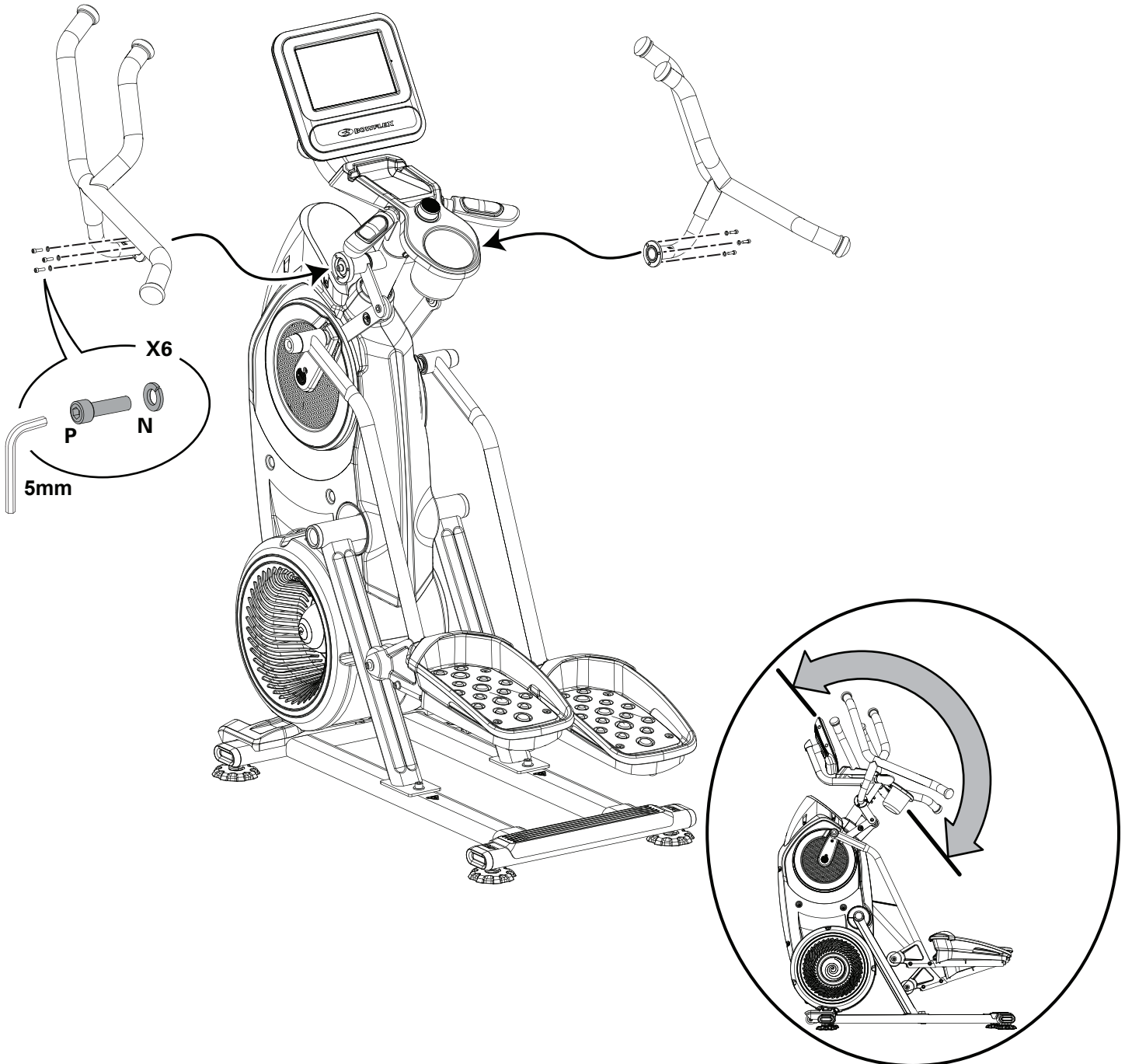

25. Final Inspection

Inspect your machine to ensure that all hardware is tight and components are properly assembled.

! Do not use until the machine has been fully assembled and inspected for correct performance in accordance with the Owner's Manual.

NOTICE: This document provides instructions for the replacement of the Handlebar Pivot Assembly on the Bowflex™ Max Total™ machine / Max Total™ 16/40 / Max Trainer™ M9.

If you need assistance, please contact Customer Service (if purchased in US/Canada) or your local distributor (if purchased outside US/Canada). To find your local distributor, go to: www.nautilusinternational.com



This icon means a potentially hazardous situation which, if not avoided, could result in death or serious injury. Read and understand all Warnings on this machine.

Nautilus, Inc., www.NautilusInc.com, 5415 Centerpoint Parkway, Groveport, OH 43125 U.S.A. - Customer Service: North America (800) 605-3369, csnls@nautilus.com | outside U.S. www.nautilusinternational.com | Printed in China | © 2020 Nautilus, Inc. | Bowflex, the B logo, Max Total, and Max Trainer are trademarks owned or licensed by Nautilus, Inc., registered or otherwise protected by common law in the United States and other nations. |

ORIGINAL DOCUMENT - ENGLISH VERSION ONLY

Important Safety Instructions - Before servicing or using this equipment, obey the following warnings:



This icon means a potentially hazardous situation which, if not avoided, could result in death or serious injury. Read and understand all Warnings on this machine.

- Read and understand the Part Replacement Procedure before working on the machine. Failure to obey the instructions and safety warnings could cause injury to the service technician or bystanders.
- Keep bystanders, children and pets away from the product being serviced at all times.
- Make sure that the repair is done in an appropriate work space away from foot traffic and exposure to bystanders.
- Disconnect all power and allow to sit for 5 minutes before you service this machine.
- Some components of the equipment can be heavy or awkward. Enlist the service of a second person when you do maintenance steps involving these components. Do not try to do heavy or awkward steps on your own.
- If replacement parts are necessary, use only genuine Nautilus replacement parts and hardware. Failure to use genuine replacement parts can cause a risk to users, keep the machine from operating correctly and will void the warranty.
- Be sure that all warning stickers and instructional placards applied to the product stay present and in good condition when doing maintenance or replacing components. If at any time the Warning labels become loose, unreadable or dislodged, replace the labels. If purchased in US/Canada, contact Customer Service for replacement labels. If purchased outside US/Canada, contact your local distributor for them.
- Do not try to change the design or functionality of the machine being serviced as this can adversely effect user safety and will void the warranty.
- Do not use the machine until all shrouds, instructions, warning labels and correct functionality have been verified and tested for correct performance.

• SAVE THESE INSTRUCTIONS.

Tools Required (not included)

5mm hex wrench
6mm hex wrench



1. Unplug the AC Adapter from the wall outlet and machine.

2. Using a 5mm hex wrench, remove the indicated hardware from the Left Upper Handlebar and place it out of the work area.

Note: Be aware that the Upper Handlebar must be supported when removing the hardware.



3. Place a rag or protective material below the Connector Arm to protect the Shroud from potential scratches from the Connector Arm.

4. Using a 6mm hex wrench, remove the indicated hardware (by oval) that connects the Connector Arm and the Handlebar Pivot Assembly.

Note: The Connector Arm will pivot downward if not lowered slowly onto the rag protecting the Shroud.

5. Using a 6mm hex wrench, remove the indicated hardware (by arrow) that connects the Handlebar Pivot Assembly to the Console Mast.

6. Slide the Handlebar Pivot Assembly off of the Console Mast and replace with the new assembly.

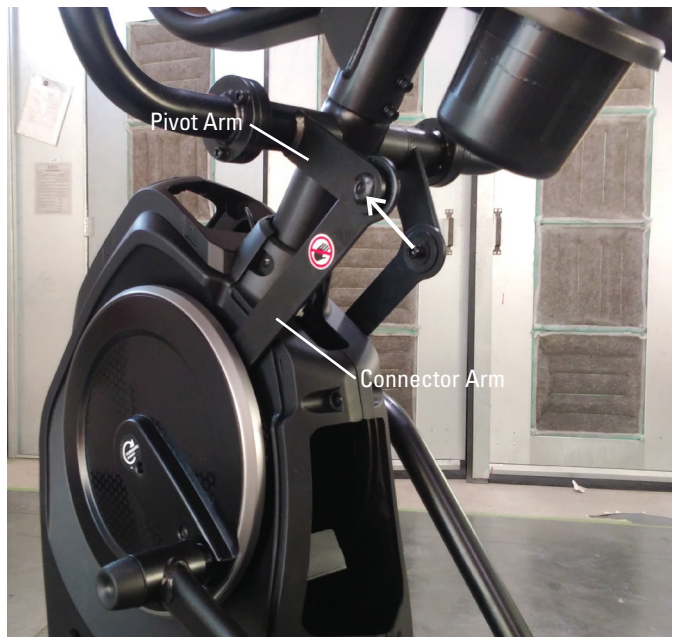

7. Installation is the reverse procedure.

8. Repeat Steps 2 - 7 on the right side of the machine.

9. Final Inspection

Inspect your machine to ensure that all hardware is tight and components are properly assembled.



Do not use until the machine has been fully assembled and inspected for correct performance in accordance with the Owner's Manual.

NOTICE: This document provides instructions for the replacement of the Cables that are the Mid Mast Cables on the Bowflex™ Max Total™ machine / Max Total™ 16/40 / Max Trainer™ M9.

If you need assistance, please contact Customer Service (if purchased in US/Canada) or your local distributor (if purchased outside US/Canada). To find your local distributor, go to: www.nautilusinternational.com



This icon means a potentially hazardous situation which, if not avoided, could result in death or serious injury. Read and understand all Warnings on this machine.

Nautilus, Inc., www.NautilusInc.com, 5415 Centerpoint Parkway, Groveport, OH 43125 U.S.A. - Customer Service: North America (800) 605-3369, csnls@nautilus.com | outside U.S. www.nautilusinternational.com | Printed in China | © 2019 Nautilus, Inc. | Bowflex, the B logo, Max Total, and Max Trainer are trademarks owned or licensed by Nautilus, Inc., registered or otherwise protected by common law in the United States and other nations. | **ORIGINAL DOCUMENT - ENGLISH VERSION ONLY**

Important Safety Instructions - Before servicing or using this equipment, obey the following warnings:



This icon means a potentially hazardous situation which, if not avoided, could result in death or serious injury. Read and understand all Warnings on this machine.

- Read and understand the Part Replacement Procedure before working on the machine. Failure to obey the instructions and safety warnings could cause injury to the service technician or bystanders.
- Keep bystanders, children and pets away from the product being serviced at all times.
- Make sure that the repair is done in an appropriate work space away from foot traffic and exposure to bystanders.
- Disconnect all power and allow to sit for 5 minutes before you service this machine.
- Some components of the equipment can be heavy or awkward. Enlist the service of a second person when you do maintenance steps involving these components. Do not try to do heavy or awkward steps on your own.
- If replacement parts are necessary, use only genuine Nautilus replacement parts and hardware. Failure to use genuine replacement parts can cause a risk to users, keep the machine from operating correctly and will void the warranty.
- Be sure that all warning stickers and instructional placards applied to the product stay present and in good condition when doing maintenance or replacing components. If at any time the Warning labels become loose, unreadable or dislodged, replace the labels. If purchased in US/Canada, contact Customer Service for replacement labels. If purchased outside US/Canada, contact your local distributor for them.
- Do not try to change the design or functionality of the machine being serviced as this can adversely effect user safety and will void the warranty.
- Do not use the machine until all shrouds, instructions, warning labels and correct functionality have been verified and tested for correct performance.

• SAVE THESE INSTRUCTIONS.

Tools Required (not included)

#2 Phillips screwdriver

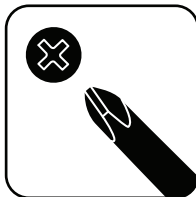

5mm hex wrench



Piece of wire or string (around 6" in length)



Note: Your machine may not match the images provided exactly.

1. Unplug the AC Adapter from the wall outlet and machine.

2. Remove the Rear Console Cover from the Console Assembly.

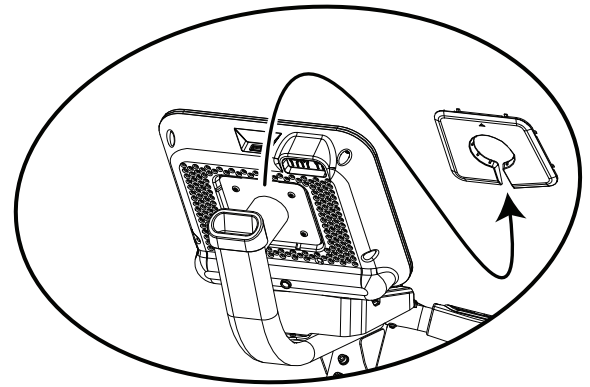

3. Using a #2 Phillips screwdriver, remove the screws (indicated by ovals) from the Console Assembly.

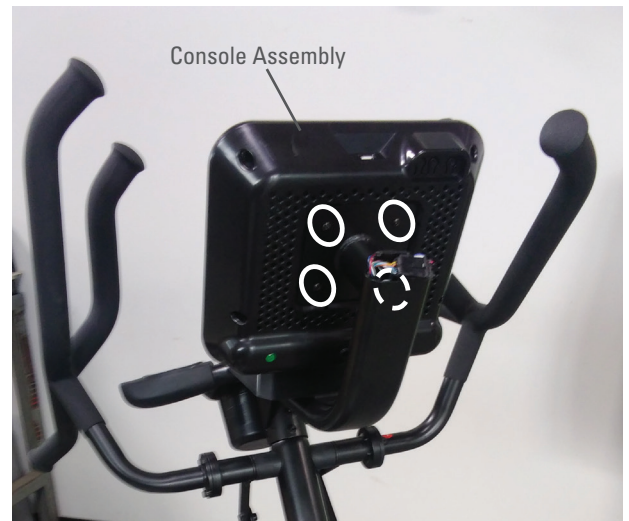

4. Carefully tilt the Console Assembly off of the Static Handlebar and expose the Cable Connections.

Note: Do not crimp any of the Console Cables. This step may require two people.

5. Carefully disconnect the Cables.

Note: Do not crimp any of the Console Cables.

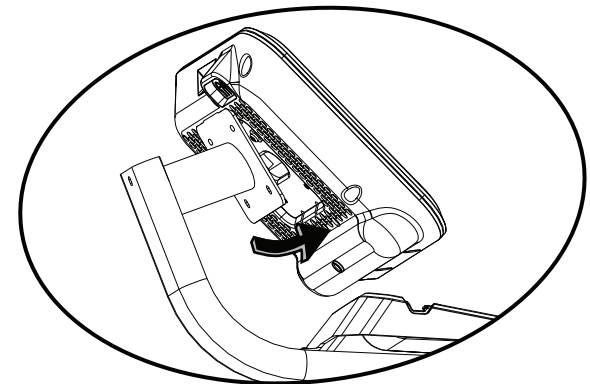

6. Using a 5mm hex wrench, remove the four screws (indicated by oval) from the Static Handlebar Assembly.



7. Carefully lift the Static Handlebar Assembly and expose the Cable Connections.

Note: Do not crimp any of the Console Cables. This step may require two people.

8. Carefully disconnect the Cables while not allowing them to fall into the Console Mast.

Note: Do not crimp any of the Console Cables.

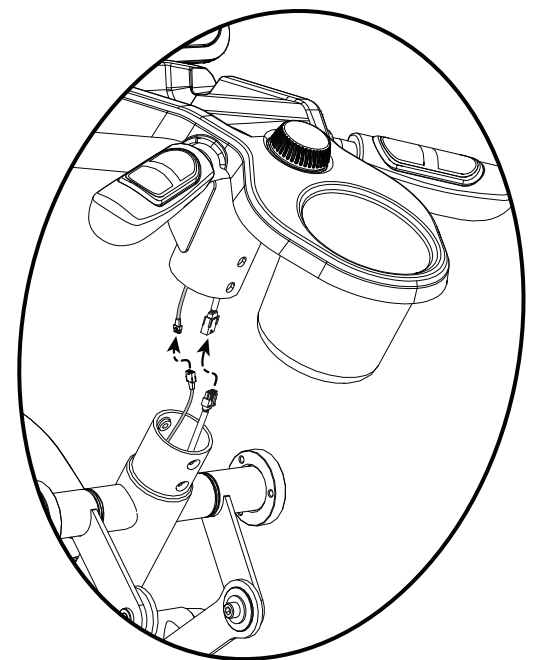

9. To protect the paint and finishes from scratches, gently place all parts on a towel or piece of cardboard before attempting to replace any Cable(s).

10. From the top of the Static Handlebar Assembly, there are 4 Cables:

Upper Body Sensor Cable (3-pin, flat connector)

To replace, go to the next Step.

Input/Output (I/O) Cable (14-pin, two-row connector)

To replace, go to the next Step.

Resistance Knob Cable (5-pin, flat connector)

To replace, go to Step 14.

Contact Heart Rate Cable (4-pin, flat connector)

The Contact Heart Rate Cable is not available for replacement.

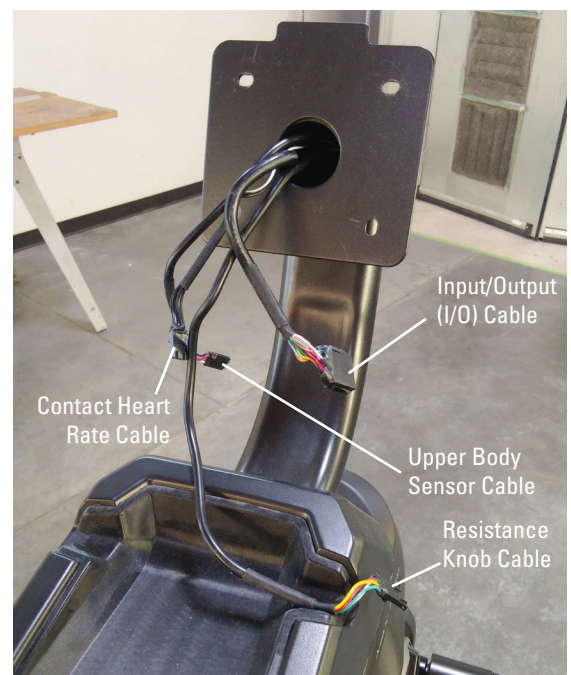

11. To replace the Upper Body Sensor or the Input/Output (I/O) Cables, attach the ends of the new Cable to the old Cable using a piece of wire or string.

Note: Only replace one Cable at a time because of the limited space.

12. Gently pull the old Cable out of the top of the Static Handlebar Assembly, routing the new Cable into place.

Note: Do not crimp any of the Console Cables.

13. Remove the piece of wire or string, and discard the old Cable.

If not replacing the Resistance Cable, go to Step 21.

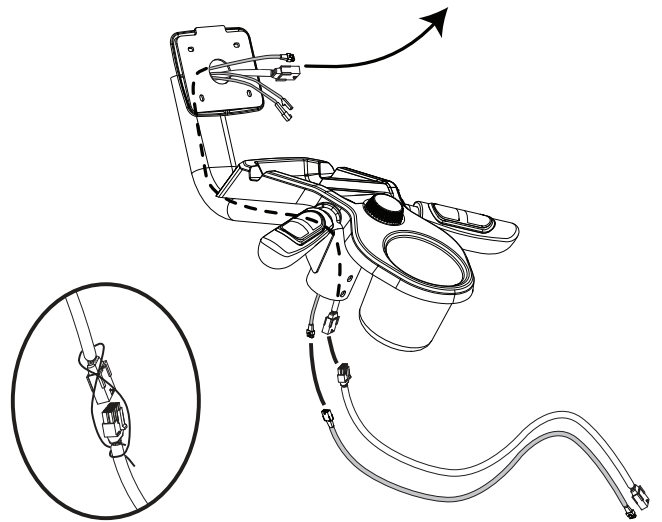

14. To replace the Resistance Cable that connects to the Resistance Knob, remove the hardware (indicated by an arrow) from the Static Handlebar Assembly using a #2 Phillips screwdriver.

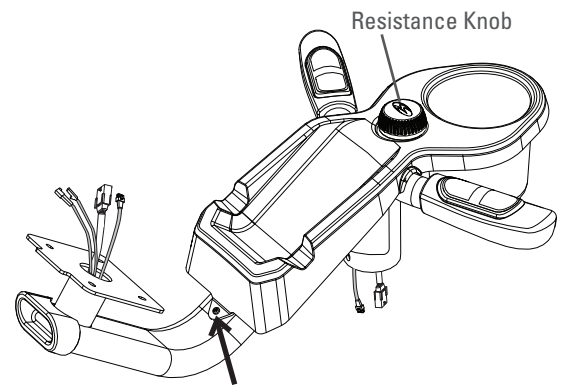

15. Gently flip over the Static Handlebar Assembly onto a towel or piece of cardboard.

16. Using a #2 Phillips screwdriver, remove the hardware (indicated by arrows) from the Static Handlebar Assembly.

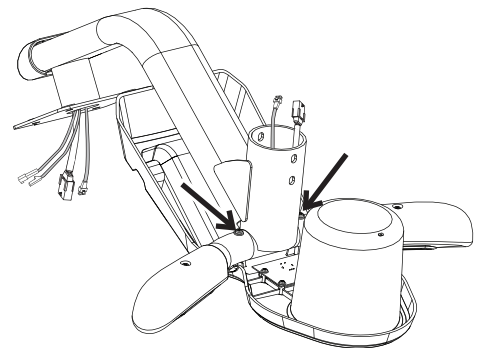

17. Slightly lift the Static Handlebars from the Tray, and disconnect the Resistance Cable.

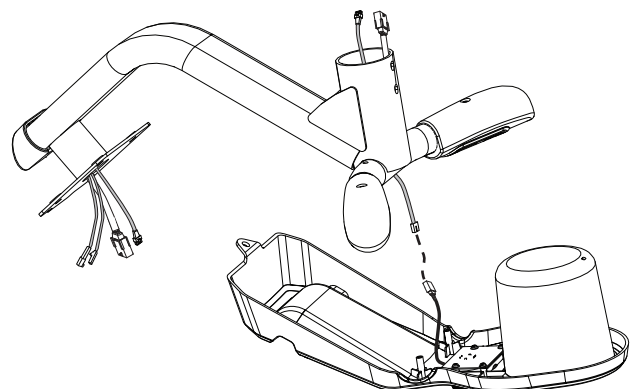

18. Using a piece of wire or string, attach the new Resistance Cable to the end of old Resistance Cable where it connected to the Resistance Knob. Be sure to connect the Cables so that when the new Resistance Cable is routed the connectors will match the old Resistance Cable connectors

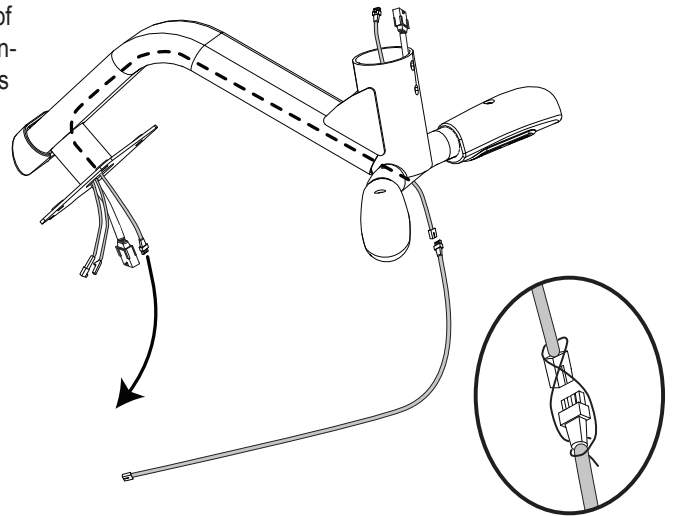

19. Gently pull the old Resistance Cable out of the top of the Static Handlebar, routing the new Resistance Cable into place.

Note: Do not crimp any of the Console Cables.

20. Remove the piece of wire or string, and discard the old Resistance Cable.

21. Re-assemble the machine in the reverse order of when the parts were removed.

Note: Do not cut or crimp the Cables. Each Cable connector (3-pin, 4-pin, 5-pin and 14-pin) has a corresponding end connector with that many openings. Be sure to fully connect the cable connectors. When attaching the Console Assembly, do not fully tighten the hardware until all hardware has been hand tightened.

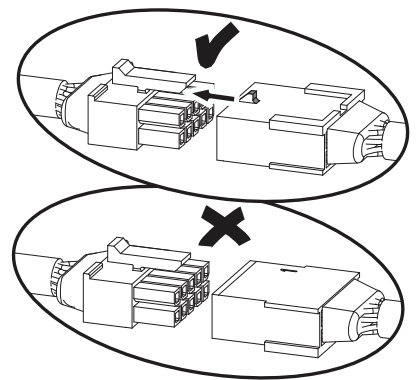

22. Final Inspection

Inspect your machine to ensure that all hardware is tight and components are properly assembled.



Do not use until the machine has been fully assembled and inspected for correct performance in accordance with the Owner's Manual.

NOTICE: This document provides instructions for the replacement of the Power Inlet on the Bowflex™ Max Total™ machine / Max Total™ 16/40 / Max Trainer™ M9.

If you need assistance, please contact Customer Service (if purchased in US/Canada) or your local distributor (if purchased outside US/Canada). To find your local distributor, go to: www.nautilusinternational.com



This icon means a potentially hazardous situation which, if not avoided, could result in death or serious injury. Read and understand all Warnings on this machine.

Nautilus, Inc., www.NautilusInc.com, 5415 Centerpoint Parkway, Groveport, OH 43125 U.S.A. - Customer Service: North America (800) 605-3369, csnls@nautilus.com | outside U.S. www.nautilusinternational.com | Printed in China | © 2020 Nautilus, Inc. | Bowflex, the B logo, Max Total, and Max Trainer are trademarks owned or licensed by Nautilus, Inc., registered or otherwise protected by common law in the United States and other nations. | ORIGINAL DOCUMENT - ENGLISH VERSION ONLY

Important Safety Instructions - Before servicing or using this equipment, obey the following warnings:



This icon means a potentially hazardous situation which, if not avoided, could result in death or serious injury. Read and understand all Warnings on this machine.

- Read and understand the Part Replacement Procedure before working on the machine. Failure to obey the instructions and safety warnings could cause injury to the service technician or bystanders.
- Keep bystanders, children and pets away from the product being serviced at all times.
- Make sure that the repair is done in an appropriate work space away from foot traffic and exposure to bystanders.
- Disconnect all power and allow to sit for 5 minutes before you service this machine.
- Some components of the equipment can be heavy or awkward. Enlist the service of a second person when you do maintenance steps involving these components. Do not try to do heavy or awkward steps on your own.
- If replacement parts are necessary, use only genuine Nautilus replacement parts and hardware. Failure to use genuine replacement parts can cause a risk to users, keep the machine from operating correctly and will void the warranty.
- Be sure that all warning stickers and instructional placards applied to the product stay present and in good condition when doing maintenance or replacing components. If at any time the Warning labels become loose, unreadable or dislodged, replace the labels. If purchased in US/Canada, contact Customer Service for replacement labels. If purchased outside US/Canada, contact your local distributor for them.
- Do not try to change the design or functionality of the machine being serviced as this can adversely effect user safety and will void the warranty.
- Do not use the machine until all shrouds, instructions, warning labels and correct functionality have been verified and tested for correct performance.

• SAVE THESE INSTRUCTIONS.

Tools Required (not included)

#2 Phillips screwdriver

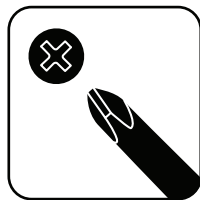

15mm wrench

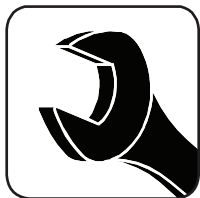

1. Unplug the AC Adapter from the wall outlet and machine.

2. Remove the Right Stabilizer Shroud from the machine.



3. Using a #2 Phillips screwdriver, remove the indicated (by ovals) screws and only loosen the lowest indicated screw (arrow) from the Right Fan Cover.

Note: Loosen the lowest screw by at least 3 full rotations.

4. The Right Fan Cover has a tab that needs to be pushed upward to clear the loosened screw. While pushing up on the tab, remove the Right Fan Cover from the assembly.

Note: the Power Cable is attached to the inside of the Right Fan Cover. Be sure not to crimp the cable by placing the Right Fan Cover close to the front of the machine.

To assist with assembly, note that the upper screw is a machine screw and not a self-tapping screw.

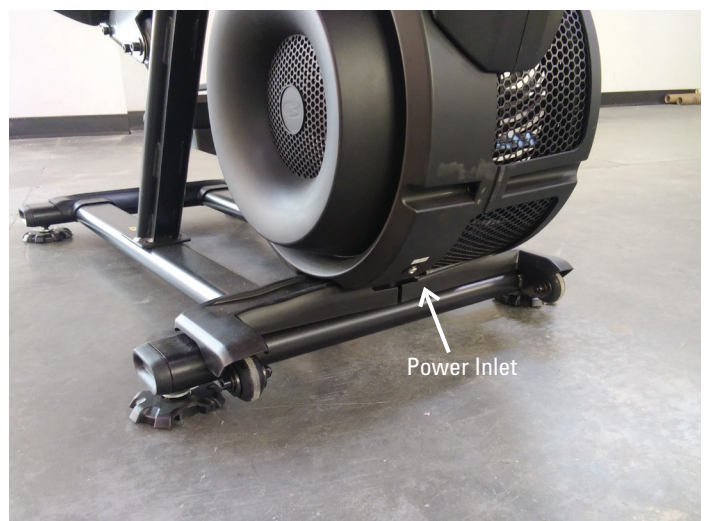
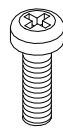

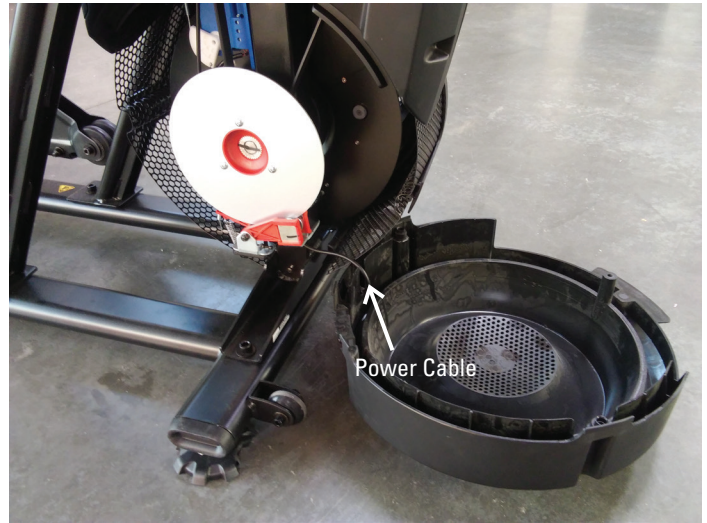

5. Disconnect the Power Inlet from the Power Connector behind the Brake Disc.

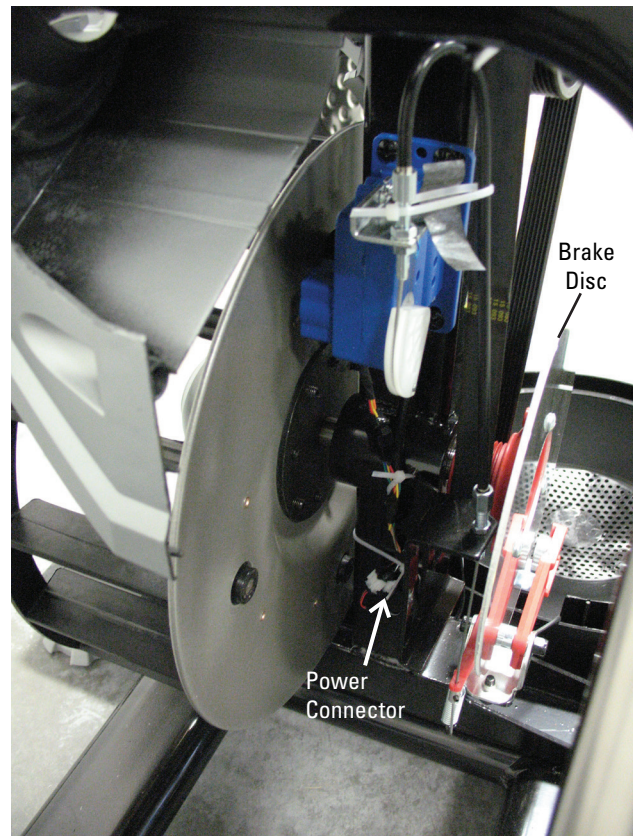

6. Using a 15mm open end wrench, remove the Securing Ring from the outside of the Right Fan Cover.

7. Remove the Power Inlet from the inside of the Right Fan Cover.

8. Installation is the reverse procedure.

9. Final Inspection

Inspect your machine to ensure that all hardware is tight and components are properly assembled.

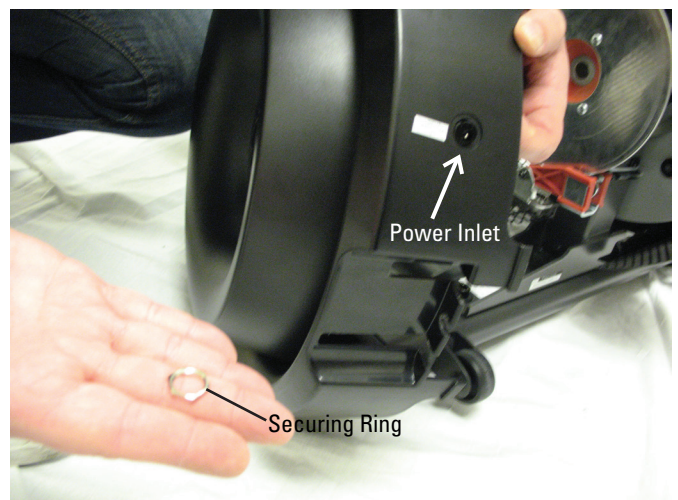

Do not use until the machine has been fully assembled and inspected for correct performance in accordance with the Owner's Manual.

NOTICE: This document provides instructions for the replacement of the Roller Wheel Assembly on the Bowflex™ Max Total™ machine / Max Total™ 16/40 / Max Trainer™ M9.

If you need assistance, please contact Customer Service (if purchased in US/Canada) or your local distributor (if purchased outside US/Canada). To find your local distributor, go to: www.nautilusinternational.com



This icon means a potentially hazardous situation which, if not avoided, could result in death or serious injury. Read and understand all Warnings on this machine.

Nautilus, Inc., www.NautilusInc.com, 5415 Centerpoint Parkway, Groveport, OH 43125 U.S.A. - Customer Service: North America (800) 605-3369, csnls@nautilus.com | outside U.S. www.nautilusinternational.com | Printed in China | © 2020 Nautilus, Inc. | Bowflex, the B logo, Max Total, and Max Trainer are trademarks owned or licensed by Nautilus, Inc., registered or otherwise protected by common law in the United States and other nations. | **ORIGINAL DOCUMENT - ENGLISH VERSION ONLY**

Important Safety Instructions - Before servicing or using this equipment, obey the following warnings:



This icon means a potentially hazardous situation which, if not avoided, could result in death or serious injury. Read and understand all Warnings on this machine.

- Read and understand the Part Replacement Procedure before working on the machine. Failure to obey the instructions and safety warnings could cause injury to the service technician or bystanders.
- Keep bystanders, children and pets away from the product being serviced at all times.
- Make sure that the repair is done in an appropriate work space away from foot traffic and exposure to bystanders.
- Disconnect all power and allow to sit for 5 minutes before you service this machine.
- Some components of the equipment can be heavy or awkward. Enlist the service of a second person when you do maintenance steps involving these components. Do not try to do heavy or awkward steps on your own.
- If replacement parts are necessary, use only genuine Nautilus replacement parts and hardware. Failure to use genuine replacement parts can cause a risk to users, keep the machine from operating correctly and will void the warranty.
- Be sure that all warning stickers and instructional placards applied to the product stay present and in good condition when doing maintenance or replacing components. If at any time the Warning labels become loose, unreadable or dislodged, replace the labels. If purchased in US/Canada, contact Customer Service for replacement labels. If purchased outside US/Canada, contact your local distributor for them.
- Do not try to change the design or functionality of the machine being serviced as this can adversely effect user safety and will void the warranty.
- Do not use the machine until all shrouds, instructions, warning labels and correct functionality have been verified and tested for correct performance.

• SAVE THESE INSTRUCTIONS.

Tools (not included)

(2) 6mm hex wrenches



1. Unplug the AC Power Adapter from the machine.

2. Using two 6mm hex wrenches, remove the hardware (indicated by arrows) from the Roller Wheel Assembly.

⚠ In order to avoid possible serious injury when removing the Roller Wheel Assembly, be careful to avoid fingers or hands being caught or pinched.

⚠ Be aware that the Pedal Arms and the Upper Handlebars are connected and when either of these parts move the other does as well.

3. Remove and dispose of the old Roller Wheels, Axle, Screws, and any Washers that were installed.

Note: Some Washers may stick to the Wheel Bracket on the Pedal Arm. Be sure to remove them before re-assembly.

4. Attach the new Roller Wheel Assembly with the provided hardware. The new Roller Wheel Assembly includes two Small Metal Washers and two Large Felt Washers. Make sure the Small Metal Washers are installed on the *outside* of the Wheel Brackets, while the Large Felt Washers are on the *inside* of the Wheel Bracket to the outside of the Roller Wheels.

Note: The Wheel Bracket is sized so the Axle can only be inserted in one direction.

5. Final Inspection

Inspect your machine to ensure that all hardware is tight and components are properly assembled.

⚠ Do not use until the machine has been fully assembled and inspected for correct performance in accordance with the Owner's Manual.

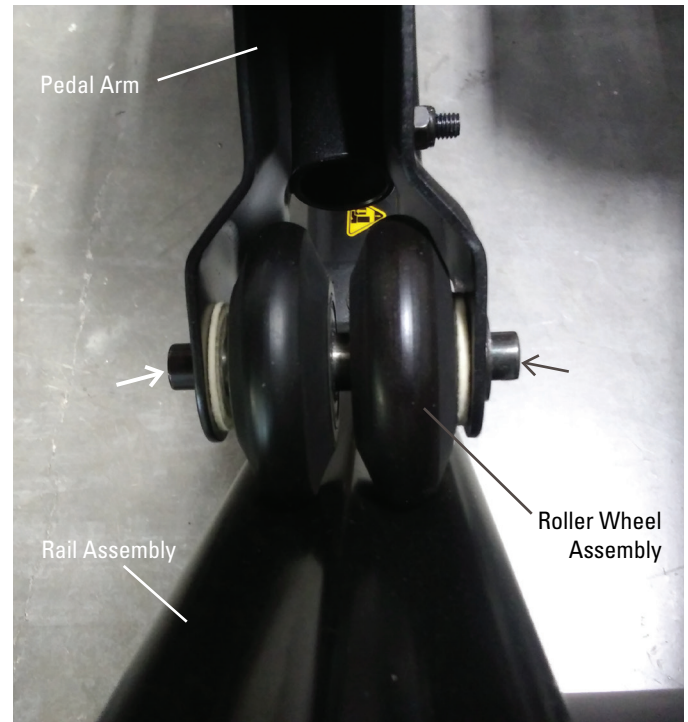

NOTICE: This document provides instructions for the replacement of the Servo Motor on the Bowflex™ Max Total™ machine / Max Total™ 16/40 / Max Trainer™ M9.

If you need assistance, please contact Customer Service (if purchased in US/Canada) or your local distributor (if purchased outside US/Canada). To find your local distributor, go to: www.nautilusinternational.com

This icon means a potentially hazardous situation which, if not avoided, could result in death or serious injury. Read and understand all Warnings on this machine.

Nautilus, Inc., www.NautilusInc.com, 5415 Centerpoint Parkway, Groveport, OH 43125 U.S.A. - Customer Service: North America (800) 605-3369, csnls@nautilus.com | outside U.S. www.nautilusinternational.com | Printed in China | © 2019 Nautilus, Inc. | Bowflex, the B logo, Max Total, and Max Trainer are trademarks owned or licensed by Nautilus, Inc., registered or otherwise protected by common law in the United States and other nations. | **ORIGINAL DOCUMENT - ENGLISH VERSION ONLY**

Important Safety Instructions - Before servicing or using this equipment, obey the following warnings:

This icon means a potentially hazardous situation which, if not avoided, could result in death or serious injury. Read and understand all Warnings on this machine.

- Read and understand the Part Replacement Procedure before working on the machine. Failure to obey the instructions and safety warnings could cause injury to the service technician or bystanders.
- Keep bystanders, children and pets away from the product being serviced at all times.
- Make sure that the repair is done in an appropriate work space away from foot traffic and exposure to bystanders.
- Disconnect all power and allow to sit for 5 minutes before you service this machine.
- Some components of the equipment can be heavy or awkward. Enlist the service of a second person when you do maintenance steps involving these components. Do not try to do heavy or awkward steps on your own.
- If replacement parts are necessary, use only genuine Nautilus replacement parts and hardware. Failure to use genuine replacement parts can cause a risk to users, keep the machine from operating correctly and will void the warranty.
- Be sure that all warning stickers and instructional placards applied to the product stay present and in good condition when doing maintenance or replacing components. If at any time the Warning labels become loose, unreadable or dislodged, replace the labels. If purchased in US/Canada, contact Customer Service for replacement labels. If purchased outside US/Canada, contact your local distributor for them.
- Do not try to change the design or functionality of the machine being serviced as this can adversely effect user safety and will void the warranty.
- Do not use the machine until all shrouds, instructions, warning labels and correct functionality have been verified and tested for correct performance.

• SAVE THESE INSTRUCTIONS.

Tools Required (not included)

#2 Phillips screwdriver

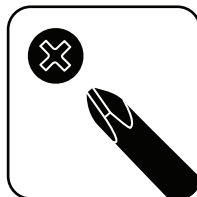

8mm wrench
10mm wrench



Note: Your machine may not match the images provided exactly.

1. With power supplied to the machine, adjust the resistance to the maximum setting.
2. Unplug the AC Adapter from the wall outlet and machine.
3. Remove the Right Stabilizer Shroud from the machine (if equipped).



4. Using a #2 Phillips screwdriver, remove the indicated (by ovals) screws and only loosen the lowest indicated screw (arrow) from the Right Fan Cover.

Note: Loosen the lowest screw by at least 3 full rotations.

5. The Right Fan Cover has a tab that needs to be pushed upward to clear the loosened screw. While pushing up on the tab, remove the Right Fan Cover from the assembly.

Note: The Power Cable is attached to the inside of the Right Fan Cover. Be sure not to crimp the cable by placing the Right Fan Cover close to the front of the machine.

To assist with assembly, note that the upper screw is a machine screw and not a self-tapping screw.

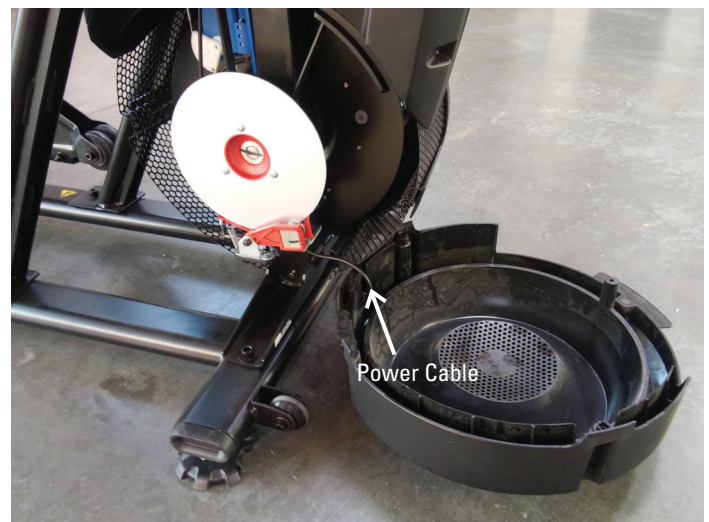
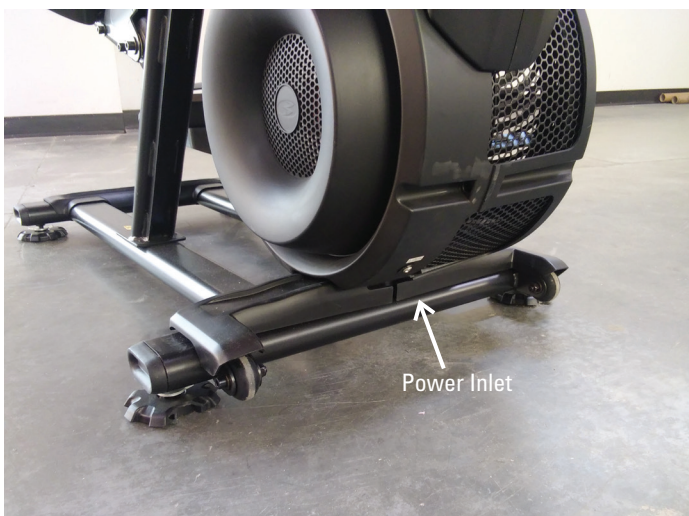
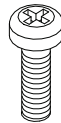

6. Using a #2 Phillips screwdriver, remove the 3 indicated screws from the Brake Disc.

7. Carefully remove the Brake Disc from the machine.

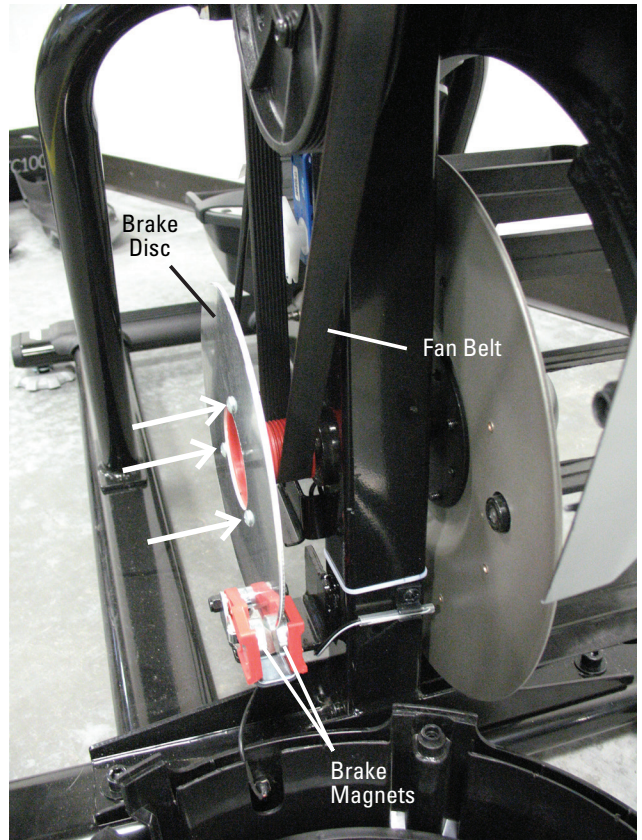

8. Using an 8mm open ended wrench, loosen the Brake Cable Securing Nut until the Brake Cable can be released from the Servo Motor Arm.

9. Remove the Brake Spring from the Brake Arm.

10. Disconnect the Cables from the Servo Motor.

11. Using a #2 Phillips screwdriver, remove the 4 screws that attach the Servo Motor to the Frame.

12. Attach the new Servo Motor to the Frame and reconnect the Cables.

13. Carefully replace the Brake Disc.

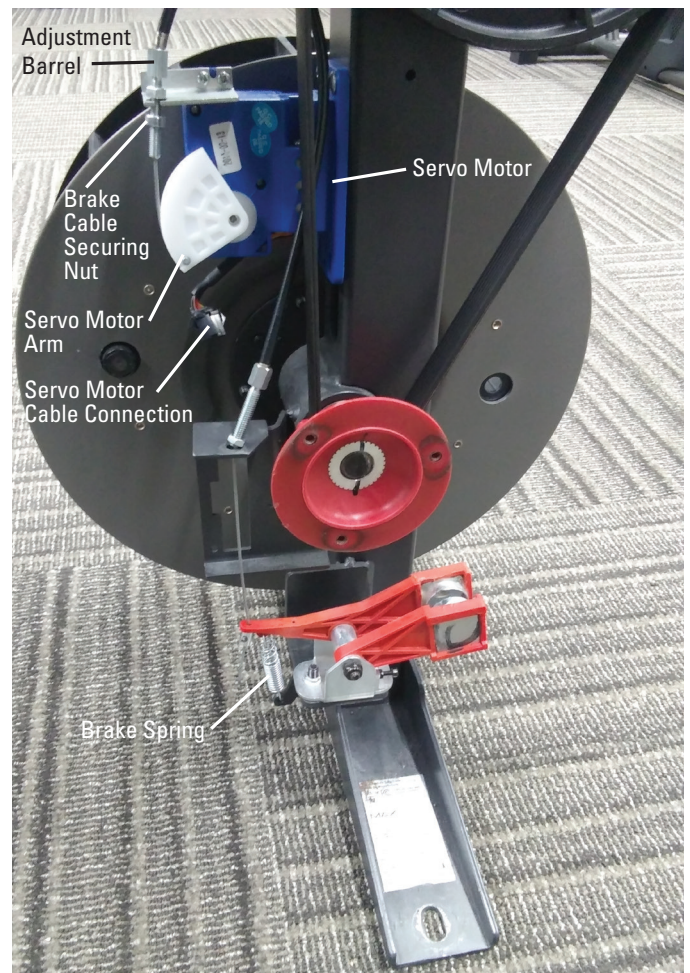

14. At the maximum resistance setting, the outer edge of the Brake Magnet should line up with the outer edge of the Brake Disc.

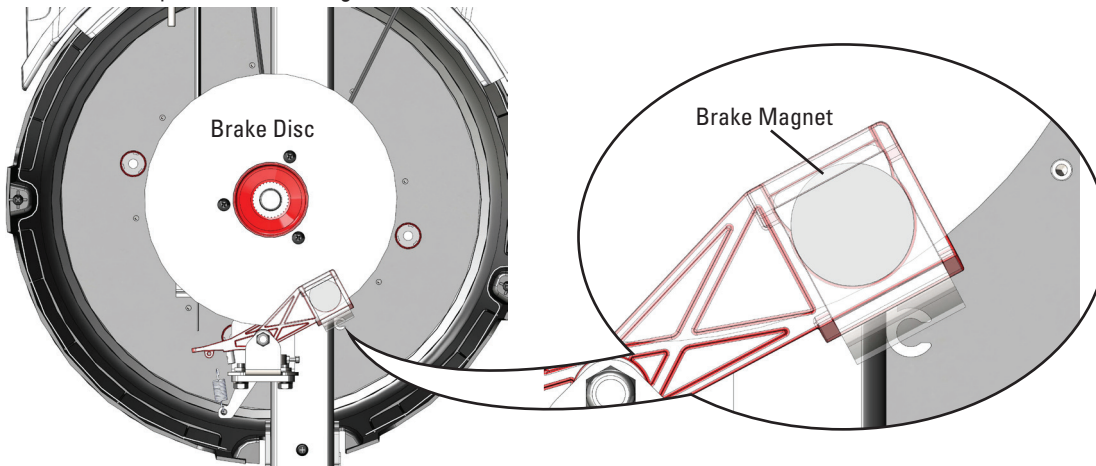

15. If the Brake Assembly needs to be adjusted, use a 8mm open ended wrench to loosen the Brake Cable Securing Nut. Turn the Adjustment Barrel by hand until the magnet is placed correctly.

16. Carefully rotate the Brake Disc. If the Brake Disc does not rub against the Brake Magnet, skip to step 19.

! Keep fingers out of any pinch opportunities when rotating the Brake Disc.

Note: The Brake Disc may appear to have a slight “wobble”. This is normal and will not affect machine function.

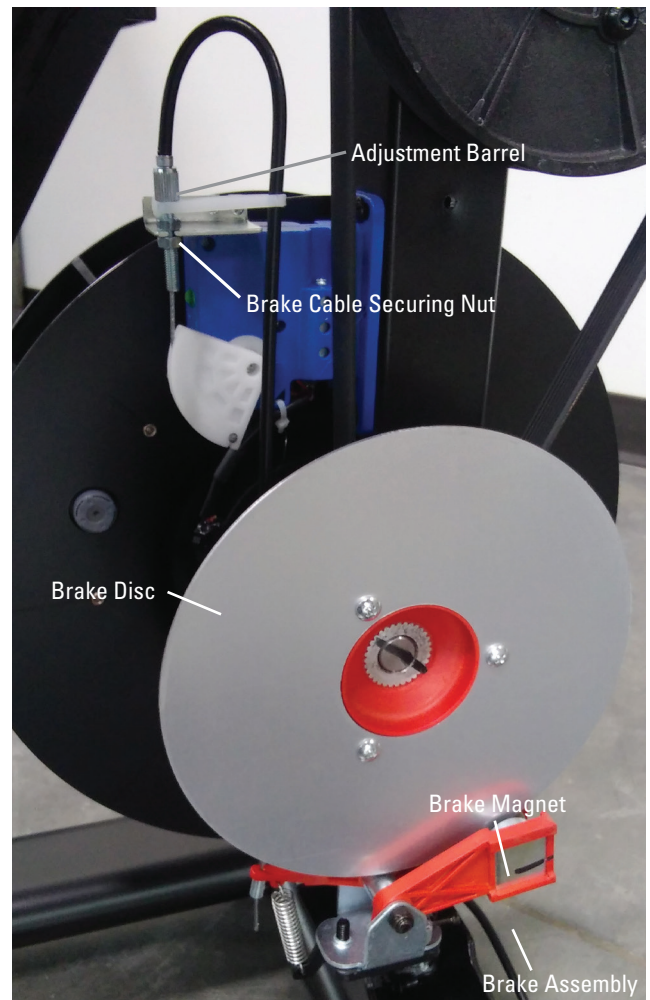

17. The Brake Magnets should be aligned with the Brake Disc and centered around the Brake Disc. If they are not aligned and centered, then the Magnets are adding drag.

18. If the Brake Assembly only needs to be slightly adjusted, loosen the front screw (indicated by double-tailed arrow) that secures the Brake Assembly using a 10mm hex wrench. Rotate the Brake Assembly until the Magnets are aligned and of equal distance from the Brake Disc.

If the Brake Assembly must be fully shifted, loosen the 2 screws (indicated by arrows) that secure the assembly and shift it until centered and aligned with the Brake Disc. Fully tighten the hardware.

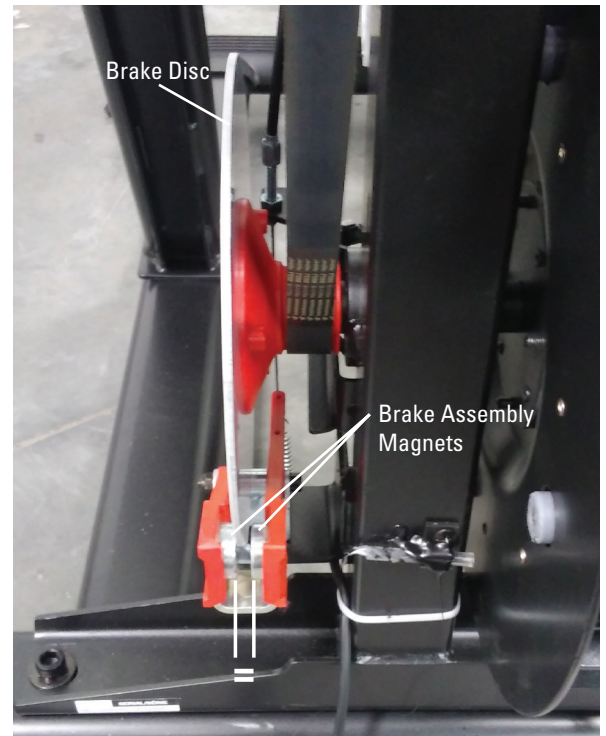
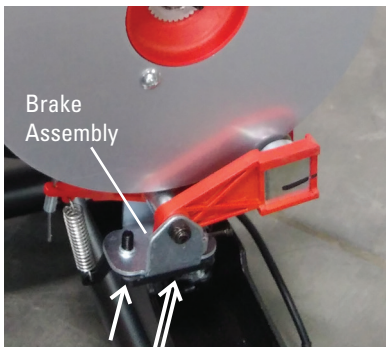

19. Installation is the reverse procedure.

20. Final Inspection

Inspect your machine to ensure that all hardware is tight and components are properly assembled.



Do not use until the machine has been fully assembled and inspected for correct performance in accordance with the Owner's Manual.

NOTICE: This document provides instructions for the replacement of the Shrouds on the Bowflex™ Max Total™ machine / Max Total™ 16/40 / Max Trainer™ M9.

If you need assistance, please contact Customer Service (if purchased in US/Canada) or your local distributor (if purchased outside US/Canada). To find your local distributor, go to: www.nautilusinternational.com

 **This icon means a potentially hazardous situation which, if not avoided, could result in death or serious injury. Read and understand all Warnings on this machine.**

Nautilus, Inc., www.NautilusInc.com, 5415 Centerpoint Parkway, Groveport, OH 43125 U.S.A. - Customer Service: North America (800) 605-3369, csnls@nautilus.com | outside U.S. www.nautilusinternational.com | Printed in China | © 2019 Nautilus, Inc. | Bowflex, the B logo, Max Total, and Max Trainer are trademarks owned or licensed by Nautilus, Inc., registered or otherwise protected by common law in the United States and other nations. | **ORIGINAL DOCUMENT - ENGLISH VERSION ONLY**

Important Safety Instructions - Before servicing or using this equipment, obey the following warnings:

 **This icon means a potentially hazardous situation which, if not avoided, could result in death or serious injury. Read and understand all Warnings on this machine.**

- Read and understand the Part Replacement Procedure before working on the machine. Failure to obey the instructions and safety warnings could cause injury to the service technician or bystanders.
- Keep bystanders, children and pets away from the product being serviced at all times.
- Make sure that the repair is done in an appropriate work space away from foot traffic and exposure to bystanders.
- Disconnect all power and allow to sit for 5 minutes before you service this machine.
- Some components of the equipment can be heavy or awkward. Enlist the service of a second person when you do maintenance steps involving these components. Do not try to do heavy or awkward steps on your own.
- If replacement parts are necessary, use only genuine Nautilus replacement parts and hardware. Failure to use genuine replacement parts can cause a risk to users, keep the machine from operating correctly and will void the warranty.
- Be sure that all warning stickers and instructional placards applied to the product stay present and in good condition when doing maintenance or replacing components. If at any time the Warning labels become loose, unreadable or dislodged, replace the labels. If purchased in US/Canada, contact Customer Service for replacement labels. If purchased outside US/Canada, contact your local distributor for them.
- Do not try to change the design or functionality of the machine being serviced as this can adversely effect user safety and will void the warranty.
- Do not use the machine until all shrouds, instructions, warning labels and correct functionality have been verified and tested for correct performance.

• SAVE THESE INSTRUCTIONS.

Tools Required (not included)

#2 Phillips screwdriver



5mm hex wrench
6mm hex wrench



(if replacing Right Fan Cover)
14mm wrench

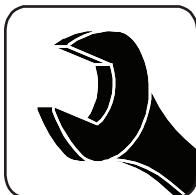

Note: Your machine may not match the images provided exactly.

1. Unplug the AC Adapter from the wall outlet and machine.

2. Using a 6mm hex wrench, remove the indicated hardware from the Right and Left Upper Handlebar and place them out of the work area.

Note: Be aware that the Right and Left Upper Handlebar must be supported when removing the hardware.

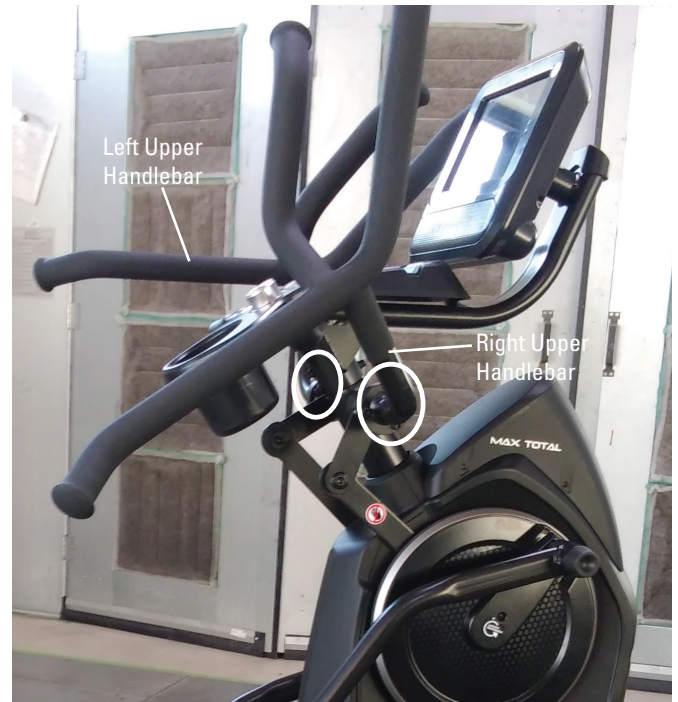

3. Using a #2 Phillips screwdriver, remove the 4 screws (2 indicated on one side) from the Upper Shroud and remove it.



4. Remove the Right and Left Stabilizer Shrouds from the machine.

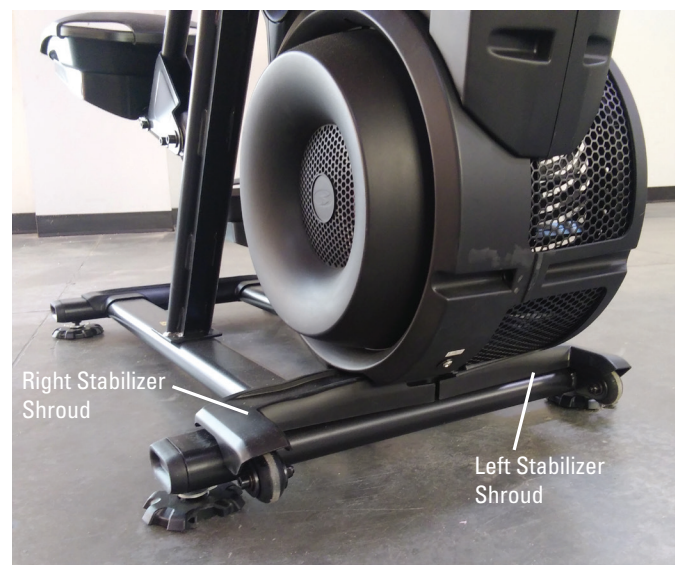

5. Using a #2 Phillips screwdriver, remove the indicated (by ovals) screws and only loosen the lowest indicated screw (arrow) from the Right Fan Cover.

Note: Loosen the lowest screw by at least 3 full rotations.

6. The Right Fan Cover has a tab that needs to be pushed upward to clear the loosened screw. While pushing up on the tab, remove the Right Fan Cover from the assembly.

Note: The Power Cable is attached to the inside of the Right Fan Cover. Be sure not to crimp the cable by placing the Right Fan Cover close to the front of the machine.

To assist with assembly, note that the upper screw is a machine screw and not a self-tapping screw.

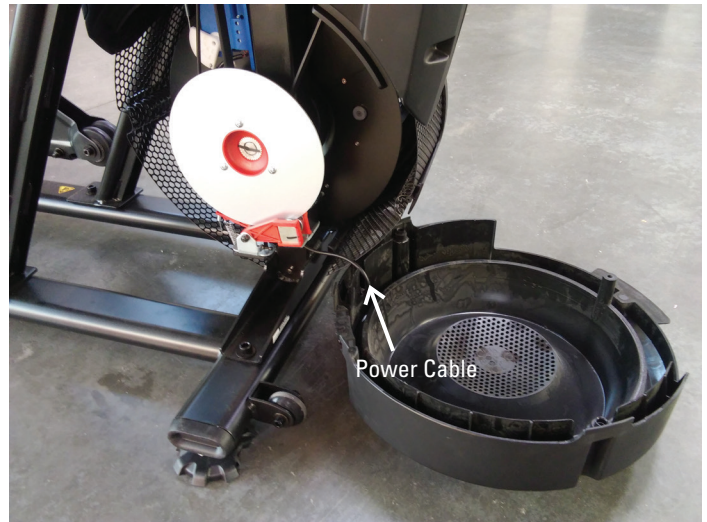
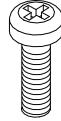

7. Remove the indicated Cap from both sides of the machine.

8. Using a 6mm hex wrench, remove the hardware exposed below the Cap from both sides of the machine.

9. Slide the Leg Assemblies off of the machine.



10. Using a #2 Phillips screwdriver, remove the indicated screw (by arrow) from the Rear Shroud.

11. Carefully remove the Rear Shroud from the machine. Place a standard screwdriver behind and near the middle of the Rear Shroud and gently pry until it releases. Then move the screwdriver to the bottom and gently pry until the Rear Shroud comes off.



12. Using a #2 Phillips screwdriver, remove the indicated (by oval) screw and only loosen the lowest indicated screw (arrow) from the Left Fan Cover.

13. The Left Fan Cover Assembly has a tab that needs to be pushed upward to clear the loosened screw. While pushing up on the tab, remove the Left Fan Cover Assembly.

14. Remove the Left Fan Cover Assembly from the machine. Be sure to note how the fan screens are set into the Left Fan Cover to assist with the replacement procedure.



15. Using a #2 Phillips screwdriver, remove the 2 indicated screws from the each of the Crank Covers.

Note: The Crank Cover screws may have been over-tightened when installed. Try not to strip the screws when removing them.

16. Remove the Crank Covers from the machine.

17. Place a rag or protective material below each of the Connector Arms to protect the Shrouds from potential scratches from the Connector Arms.

18. Using a 6mm hex wrench, remove the hardware that connects each of the Connector Arms to the Pivot Arms.

Note: The Connector Arm will pivot downward if not lowered slowly onto the rag protecting the Shroud.

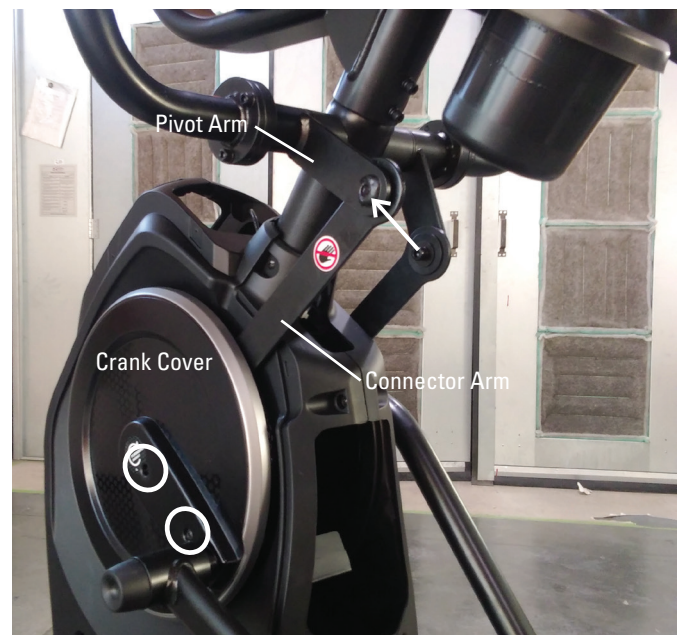

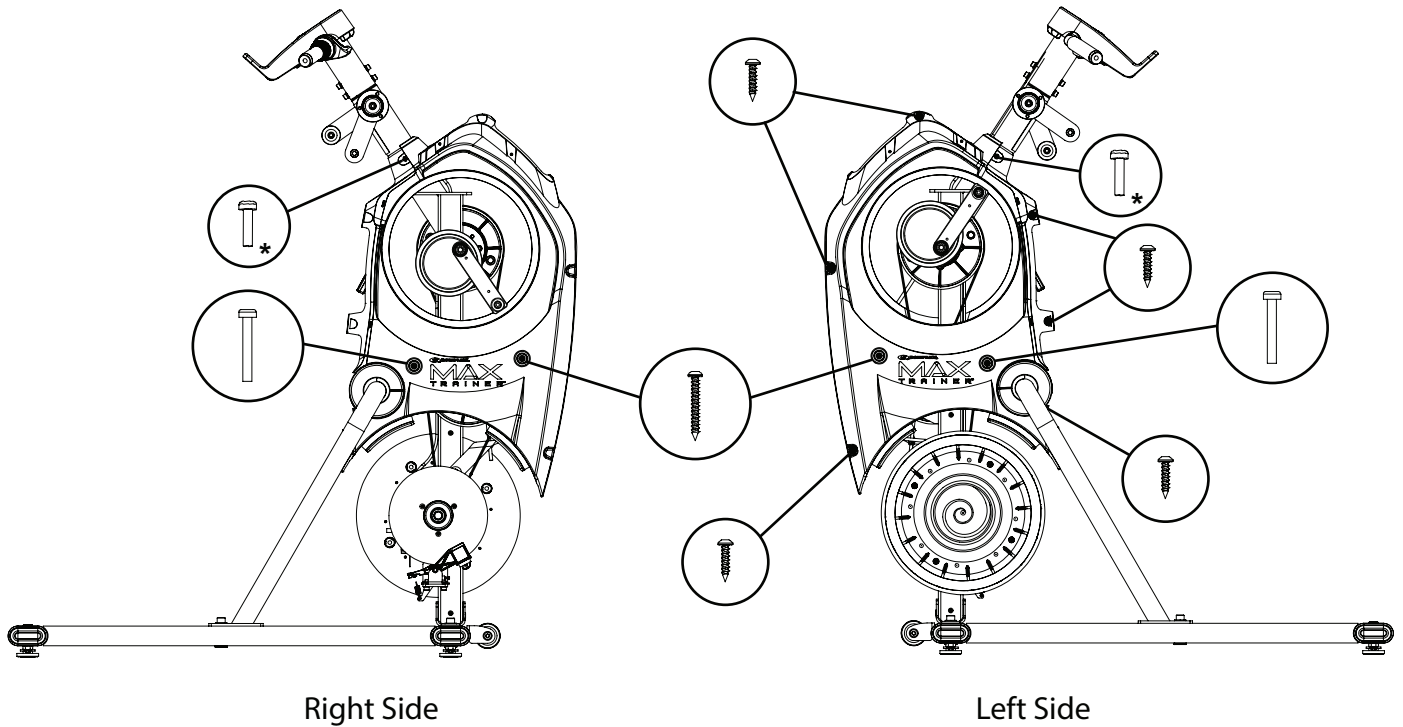

19. Using a #2 Phillips screwdriver, remove the screws from the Right and Left Shrouds. (3 screws on the Right Shroud, 9 on the Left Shroud) Remove the upper screws labeled ' * ' last.

20. Carefully remove the Shrouds from the machine.

If replacing the Right Fan Cover:

A. Using a 14mm open face wrench, remove the Securing Ring from the outside of the Right Fan Cover.

B. Remove the Power Inlet from the inside of the Right Fan Cover.

21. Installation is the reverse procedure.

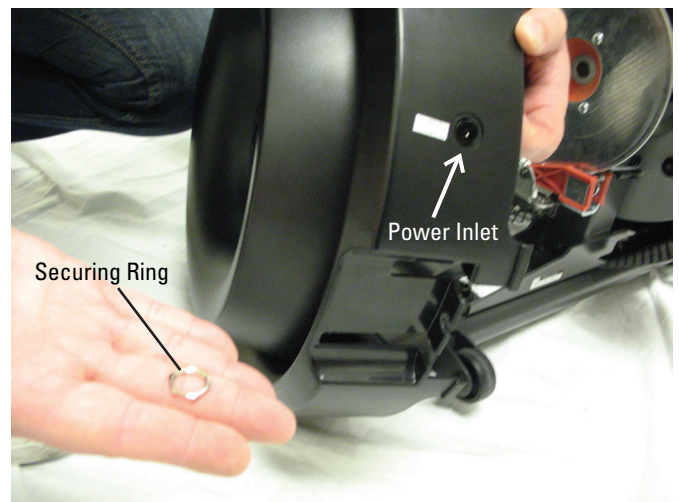

22. Final Inspection

Inspect your machine to ensure that all hardware is tight and components are properly assembled.



Do not use until the machine has been fully assembled and inspected for correct performance in accordance with the Owner's Manual.

NOTICE: This document provides instructions for the replacement of the Speed Sensor on the Bowflex™ Max Total™ machine / Max Total™ 16/40 / Max Trainer™ M9.

If you need assistance, please contact Customer Service (if purchased in US/Canada) or your local distributor (if purchased outside US/Canada). To find your local distributor, go to: www.nautilusinternational.com

 This icon means a potentially hazardous situation which, if not avoided, could result in death or serious injury. Read and understand all Warnings on this machine.

Nautilus, Inc., www.NautilusInc.com, 5415 Centerpoint Parkway, Groveport, OH 43125 U.S.A. - Customer Service: North America (800) 605-3369, csnls@nautilus.com | outside U.S. www.nautilusinternational.com | Printed in China | © 2020 Nautilus, Inc. | Bowflex, the B logo, Max Total, and Max Trainer are trademarks owned or licensed by Nautilus, Inc., registered or otherwise protected by common law in the United States and other nations. | **ORIGINAL DOCUMENT - ENGLISH VERSION ONLY**

Important Safety Instructions - Before servicing or using this equipment, obey the following warnings:

 This icon means a potentially hazardous situation which, if not avoided, could result in death or serious injury. Read and understand all Warnings on this machine.

- Read and understand the Part Replacement Procedure before working on the machine. Failure to obey the instructions and safety warnings could cause injury to the service technician or bystanders.
- Keep bystanders, children and pets away from the product being serviced at all times.
- Make sure that the repair is done in an appropriate work space away from foot traffic and exposure to bystanders.
- Disconnect all power and allow to sit for 5 minutes before you service this machine.
- Some components of the equipment can be heavy or awkward. Enlist the service of a second person when you do maintenance steps involving these components. Do not try to do heavy or awkward steps on your own.
- If replacement parts are necessary, use only genuine Nautilus replacement parts and hardware. Failure to use genuine replacement parts can cause a risk to users, keep the machine from operating correctly and will void the warranty.
- Be sure that all warning stickers and instructional placards applied to the product stay present and in good condition when doing maintenance or replacing components. If at any time the Warning labels become loose, unreadable or dislodged, replace the labels. If purchased in US/Canada, contact Customer Service for replacement labels. If purchased outside US/Canada, contact your local distributor for them.
- Do not try to change the design or functionality of the machine being serviced as this can adversely effect user safety and will void the warranty.
- Do not use the machine until all shrouds, instructions, warning labels and correct functionality have been verified and tested for correct performance.

• SAVE THESE INSTRUCTIONS.

Tools Required (not included)

#2 Phillips screwdriver



1. Unplug the AC Adapter from the wall outlet and machine.
2. Remove the Right Stabilizer Shroud from the machine.



3. Using a #2 Phillips screwdriver, remove the indicated (by ovals) screws and only loosen the lowest indicated screw (arrow) from the Right Fan Cover.

Note: Loosen the lowest screw by at least 3 full rotations.

4. The Right Fan Cover has a tab that needs to be pushed upward to clear the loosened screw. While pushing up on the tab, remove the Right Fan Cover from the assembly.

Note: the Power Cable is attached to the inside of the Right Fan Cover. Be sure not to crimp the cable by placing the Right Fan Cover close to the front of the machine.

To assist with assembly, note that the upper screw is a machine screw and not a self-tapping screw.

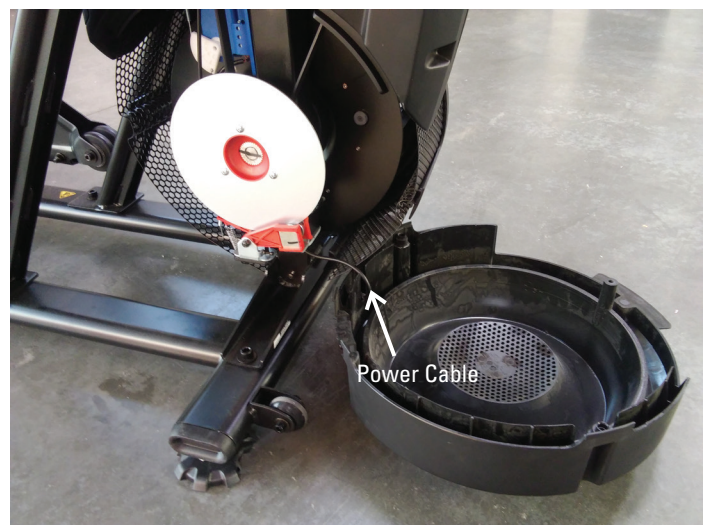
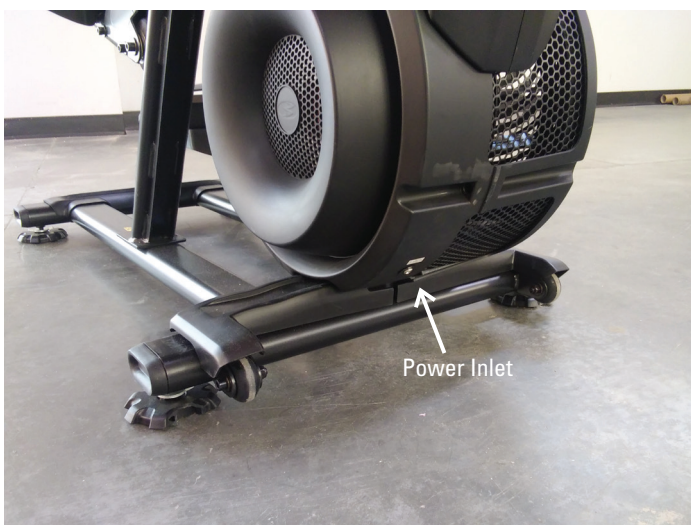
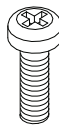

Note: Left Fan Cover is hidden for image clarity.

5. Using a #2 Phillips screwdriver, remove the screw that attaches the Speed Sensor.

Note: To assist with re-assembly, note that the new Speed Sensor must be 3mm (1/8") from the Speed Sensor Magnet on the Fan Disc.

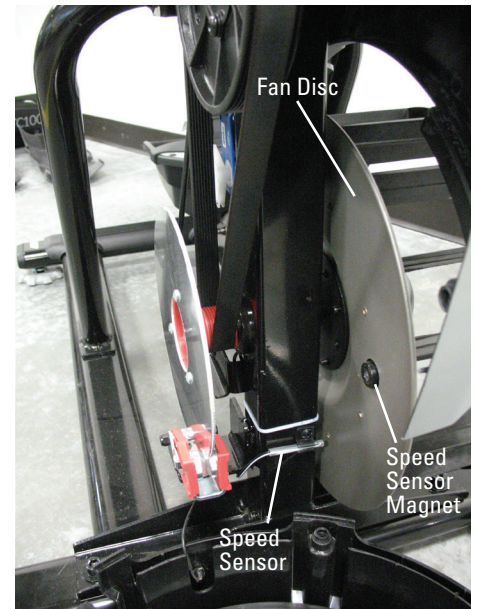

6. Disconnect the Speed Sensor Cable noting how it was routed for re-assembly.

Note: Do not crimp the Cables.

7. Using a #2 Phillips screwdriver, attach the new Speed Sensor. Be sure to place it 3mm (1/8") from the Speed Sensor Magnet on the Fan Disc.

8. Route the new Speed Sensor Cable under the bracket and connect the cable.

9. Installation is the reverse procedure.

10. Final Inspection

Inspect your machine to ensure that all hardware is tight and components are properly assembled.

 **Do not use until the machine has been fully assembled and inspected for correct performance in accordance with the Owner's Manual.**

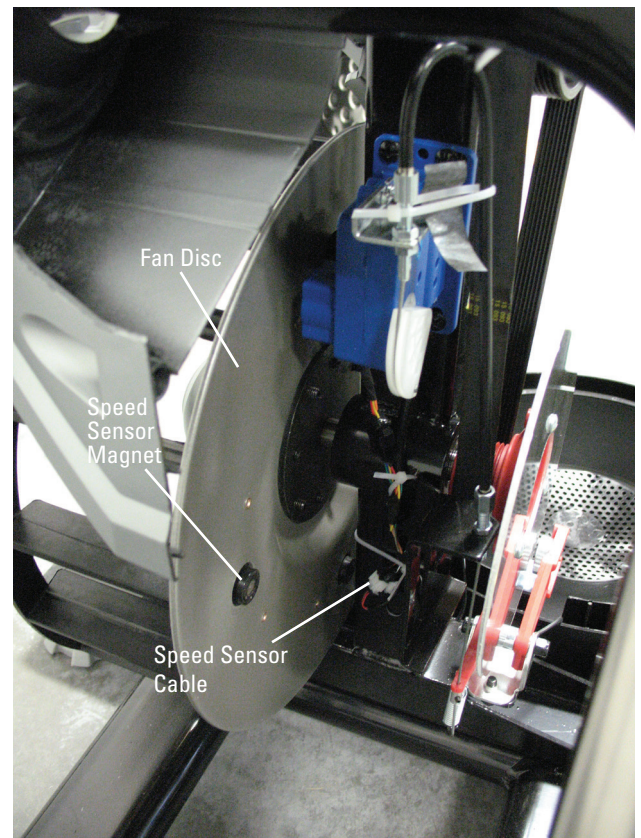

NOTICE: This document provides instructions for the replacement of the Static Handlebar Assembly on the Bowflex™ Max Total™ machine / Max Total™ 16/40 / Max Trainer™ M9.

If you need assistance, please contact Customer Service (if purchased in US/Canada) or your local distributor (if purchased outside US/Canada). To find your local distributor, go to: www.nautilusinternational.com

 **This icon means a potentially hazardous situation which, if not avoided, could result in death or serious injury. Read and understand all Warnings on this machine.**

Nautilus, Inc., www.NautilusInc.com, 5415 Centerpoint Parkway, Groveport, OH 43125 U.S.A. - Customer Service: North America (800) 605-3369, csnls@nautilus.com | outside U.S. www.nautilusinternational.com | Printed in China | © 2019 Nautilus, Inc. | Bowflex, the B logo, Max Total, and Max Trainer are trademarks owned or licensed by Nautilus, Inc., registered or otherwise protected by common law in the United States and other nations. | **ORIGINAL DOCUMENT - ENGLISH VERSION ONLY**

Important Safety Instructions - Before servicing or using this equipment, obey the following warnings:

 **This icon means a potentially hazardous situation which, if not avoided, could result in death or serious injury. Read and understand all Warnings on this machine.**

- Read and understand the Part Replacement Procedure before working on the machine. Failure to obey the instructions and safety warnings could cause injury to the service technician or bystanders.
- Keep bystanders, children and pets away from the product being serviced at all times.
- Make sure that the repair is done in an appropriate work space away from foot traffic and exposure to bystanders.
- Disconnect all power and allow to sit for 5 minutes before you service this machine.
- Some components of the equipment can be heavy or awkward. Enlist the service of a second person when you do maintenance steps involving these components. Do not try to do heavy or awkward steps on your own.
- If replacement parts are necessary, use only genuine Nautilus replacement parts and hardware. Failure to use genuine replacement parts can cause a risk to users, keep the machine from operating correctly and will void the warranty.
- Be sure that all warning stickers and instructional placards applied to the product stay present and in good condition when doing maintenance or replacing components. If at any time the Warning labels become loose, unreadable or dislodged, replace the labels. If purchased in US/Canada, contact Customer Service for replacement labels. If purchased outside US/Canada, contact your local distributor for them.
- Do not try to change the design or functionality of the machine being serviced as this can adversely effect user safety and will void the warranty.
- Do not use the machine until all shrouds, instructions, warning labels and correct functionality have been verified and tested for correct performance.

• SAVE THESE INSTRUCTIONS.

Tools Required (not included)

5mm hex wrench



#2 Phillips screwdriver

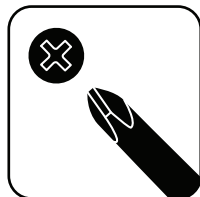

Note: Your machine may not match the images provided exactly.

1. Unplug the AC Adapter from the wall outlet and machine.

2. Remove the Rear Console Cover from the Console Assembly.

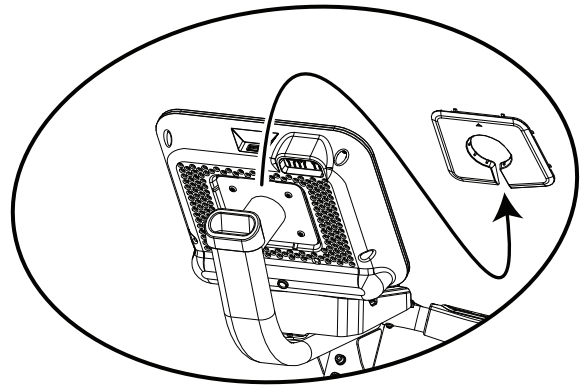

3. Using a #2 Phillips screwdriver, remove the screws (indicated by ovals) from the Console Assembly.



4. Carefully tilt the Console Assembly off of the Static Handlebar and expose the Cable Connections.

Note: Do not crimp any of the Console Cables. This step may require two people.

5. Carefully disconnect the Cables.

Note: Do not crimp any of the Console Cables.

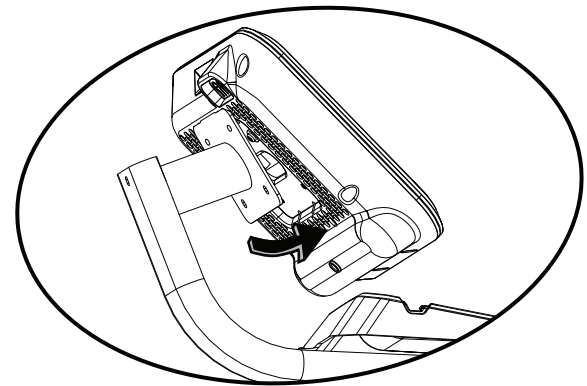

6. Using a 5mm hex wrench, remove the four screws (indicated by oval) from the Static Handlebar Assembly.



7. Carefully lift the Static Handlebar Assembly and expose the Cable Connections.

Note: Do not crimp any of the Console Cables. This step may require two people.

8. Carefully disconnect the Cables while not allowing them to fall into the Console Mast.

Note: Do not crimp any of the Console Cables.

9. Replace the old Static Handlebar Assembly for the new one.

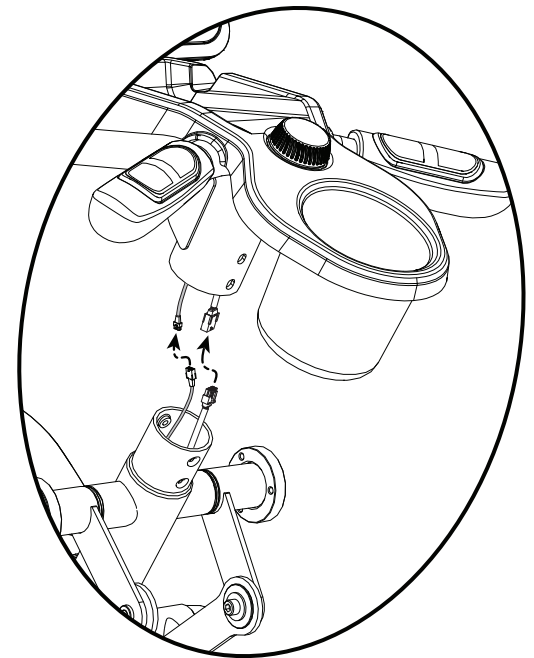

10. Installation is the reverse procedure.

Note: Do not cut or crimp the Cables. Each Cable connector (3-pin, 4-pin, 5-pin and 12-pin) has a corresponding end connector with that many openings. Be sure to fully connect the cable connectors.

11. Final Inspection

Inspect your machine to ensure that all hardware is tight and components are properly assembled.

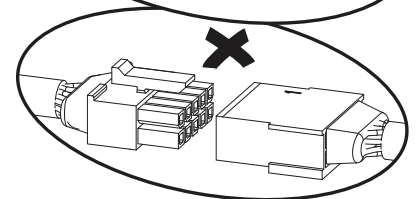
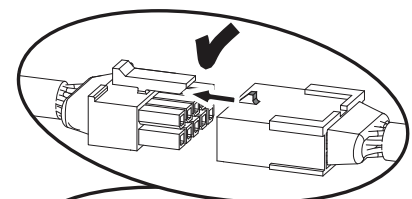

Do not use until the machine has been fully assembled and inspected for correct performance in accordance with the Owner's Manual.

NOTICE: This document provides instructions for the replacement of the Upper Body Sensor Assembly on the Bowflex™ Max Total™ machine / Max Total™ 16/40.

If you need assistance, please contact Customer Service (if purchased in US/Canada) or your local distributor (if purchased outside US/Canada). To find your local distributor, go to: www.nautilusinternational.com



This icon means a potentially hazardous situation which, if not avoided, could result in death or serious injury. Read and understand all Warnings on this machine.

Nautilus, Inc., www.NautilusInc.com, 5415 Centerpoint Parkway, Groveport, OH 43125 U.S.A. - Customer Service: North America (800) 605-3369, csnls@nautilus.com | outside U.S. www.nautilusinternational.com | Printed in China | © 2020 Nautilus, Inc. | Bowflex, the B logo, and Max Total are trademarks owned or licensed by Nautilus, Inc., registered or otherwise protected by common law in the United States and other nations. | **ORIGINAL DOCUMENT - ENGLISH VERSION ONLY**

Important Safety Instructions - Before servicing or using this equipment, obey the following warnings:



This icon means a potentially hazardous situation which, if not avoided, could result in death or serious injury. Read and understand all Warnings on this machine.

- Read and understand the Part Replacement Procedure before working on the machine. Failure to obey the instructions and safety warnings could cause injury to the service technician or bystanders.
- Keep bystanders, children and pets away from the product being serviced at all times.
- Make sure that the repair is done in an appropriate work space away from foot traffic and exposure to bystanders.
- Disconnect all power and allow to sit for 5 minutes before you service this machine.
- Some components of the equipment can be heavy or awkward. Enlist the service of a second person when you do maintenance steps involving these components. Do not try to do heavy or awkward steps on your own.
- If replacement parts are necessary, use only genuine Nautilus replacement parts and hardware. Failure to use genuine replacement parts can cause a risk to users, keep the machine from operating correctly and will void the warranty.
- Be sure that all warning stickers and instructional placards applied to the product stay present and in good condition when doing maintenance or replacing components. If at any time the Warning labels become loose, unreadable or dislodged, replace the labels. If purchased in US/Canada, contact Customer Service for replacement labels. If purchased outside US/Canada, contact your local distributor for them.
- Do not try to change the design or functionality of the machine being serviced as this can adversely effect user safety and will void the warranty.
- Do not use the machine until all shrouds, instructions, warning labels and correct functionality have been verified and tested for correct performance.

• SAVE THESE INSTRUCTIONS.

Tools Required (not included)

#2 Phillips screwdriver

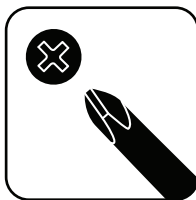

2mm hex wrench
5mm hex wrench
6mm hex wrench



(if replacing Right Fan Cover)
14mm wrench



Note: Your machine may not match the images provided exactly.

1. Unplug the AC Adapter from the wall outlet and machine.

2. Using a 6mm hex wrench, remove the indicated hardware from the Right and Left Upper Handlebar.

Note: Be aware that the Right and Left Upper Handlebar must be supported when removing the hardware.

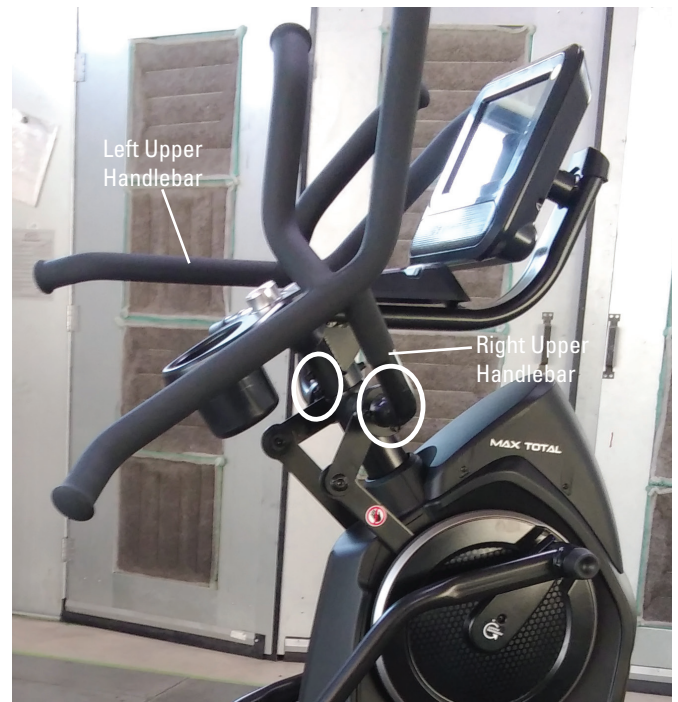

3. Using a #2 Phillips screwdriver, remove the 4 screws (2 indicated on one side) from the Upper Shroud.



4. Remove the Right Stabilizer Shroud from the machine.



5. Using a #2 Phillips screwdriver, remove the indicated (by ovals) screws and only loosen the lowest indicated screw (arrow) from the Right Fan Cover.

Note: Loosen the lowest screw by at least 3 full rotations.

6. The Right Fan Cover has a tab that needs to be pushed upward to clear the loosened screw. While pushing up on the tab, remove the Right Fan Cover from the assembly.

Note: The Power Cable is attached to the inside of the Right Fan Cover. Be sure not to crimp the cable by placing the Right Fan Cover close to the front of the machine.

To assist with assembly, note that the upper screw is a machine screw and not a self-tapping screw.

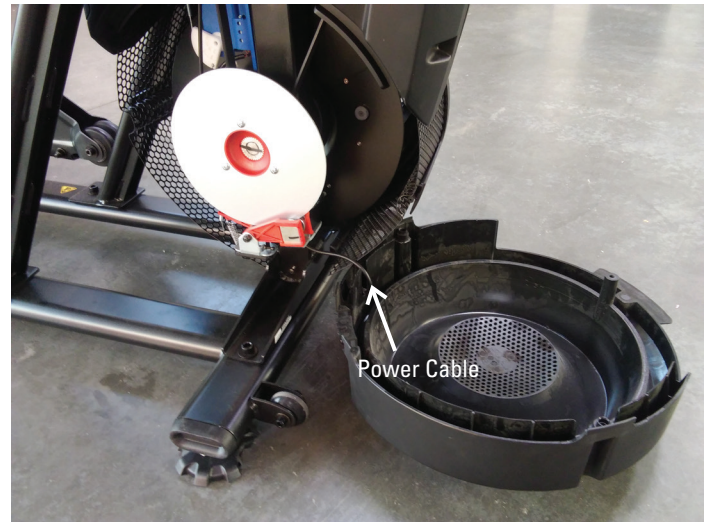
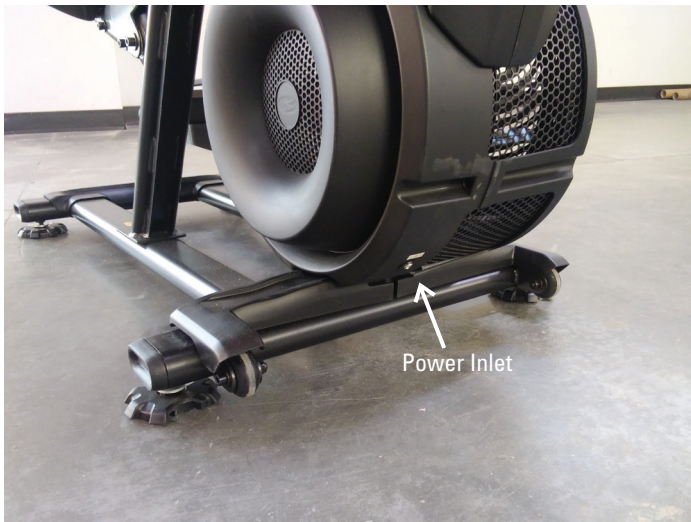
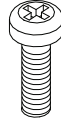

7. Remove the indicated Cap from the machine.

8. Using a 6mm hex wrench, remove the hardware exposed below the Cap from the machine.

9. Slide the Right Leg Assembly off of the machine.



10. Using a #2 Phillips screwdriver, remove the indicated screw (by arrow) from the Rear Shroud.

11. Carefully remove the Rear Shroud from the machine. Place a standard screwdriver behind and near the middle of the Rear Shroud and gently pry until it releases. Then move the screwdriver to the bottom and gently pry until the Rear Shroud comes off.



12. Using a 5mm hex wrench, remove the hardware (indicated by ovals) from the Right Upper Handlebar.

Note: Be aware that the Upper Handlebar must be supported when removing the hardware.

13. Place a rag or protective material below the Right Connector Arm to protect the Shrouds from potential scratches from the Right Connector Arm.

14. Using a 6mm hex wrench, remove the hardware that connects the Right Connector Arm to the Right Pivot Arm (indicated by arrow).

Note: The Connector Arm will pivot downward if not lowered slowly onto the rag protecting the Shroud.

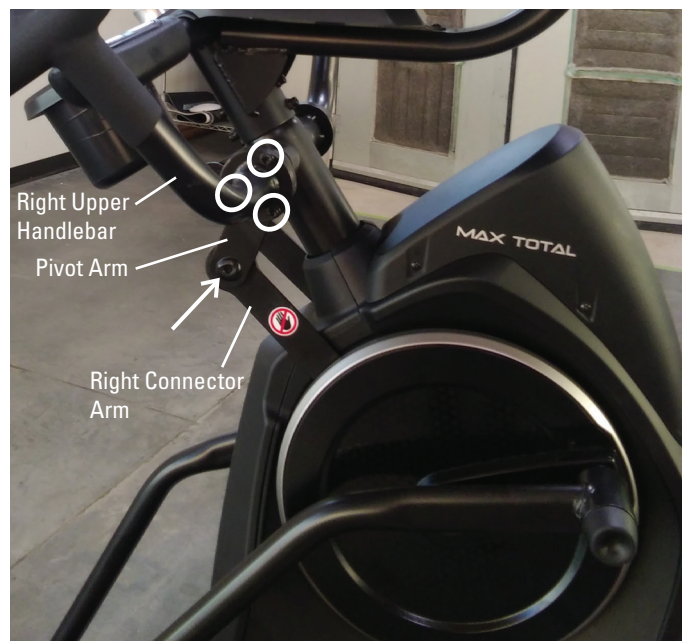

15. Using a #2 Phillips screwdriver, remove the 2 indicated screws from the Right Crank Cover.

Note: The Crank Cover screws may have been over-tightened when installed. Try not to strip the screws when removing them.

16. Remove the Right Crank Cover from the machine.

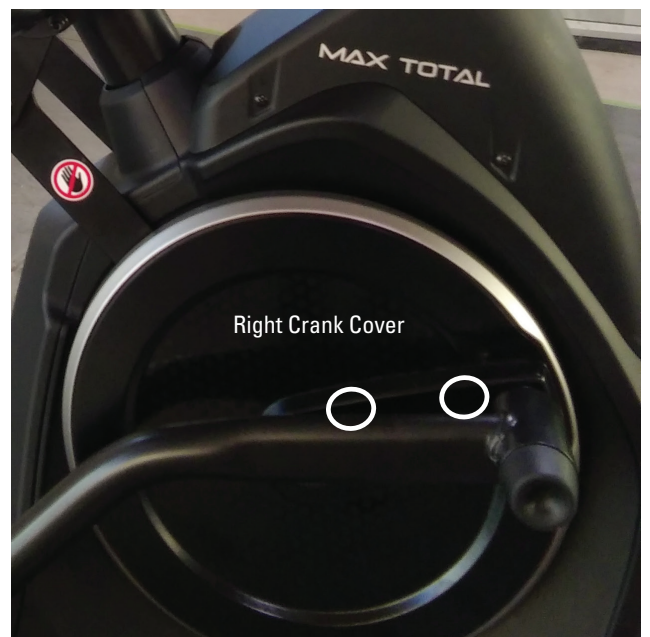

17. Using a #2 Phillips screwdriver, remove the indicated screws from the Right shroud (3 screws on the Right Shroud). Remove the upper screws labeled ' * ' last.

18. Carefully remove the Right Shroud from the machine.

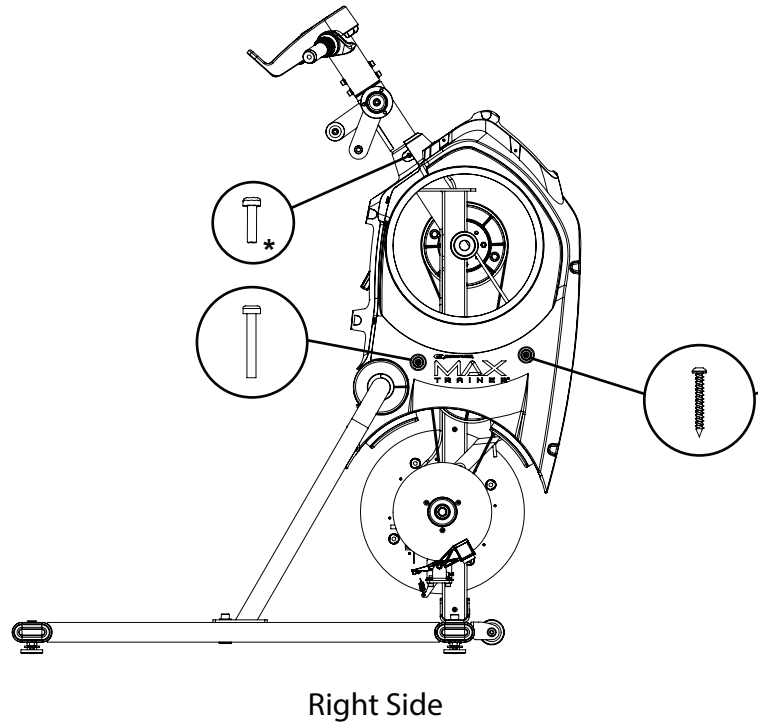

19. Using a #2 Phillips screwdriver, remove the screws (indicated by arrows) that secure the Upper Body Sensor. Allow the Upper Body Sensor to hang on the Cable, away from the Right Crank Arm.

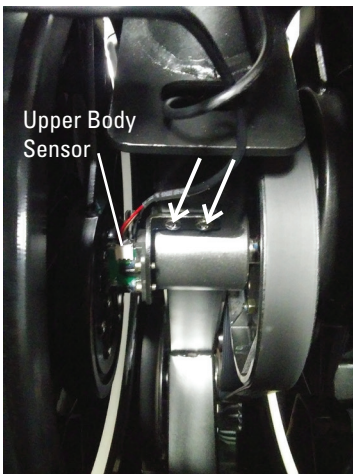

Note: View into Shrouds from above.

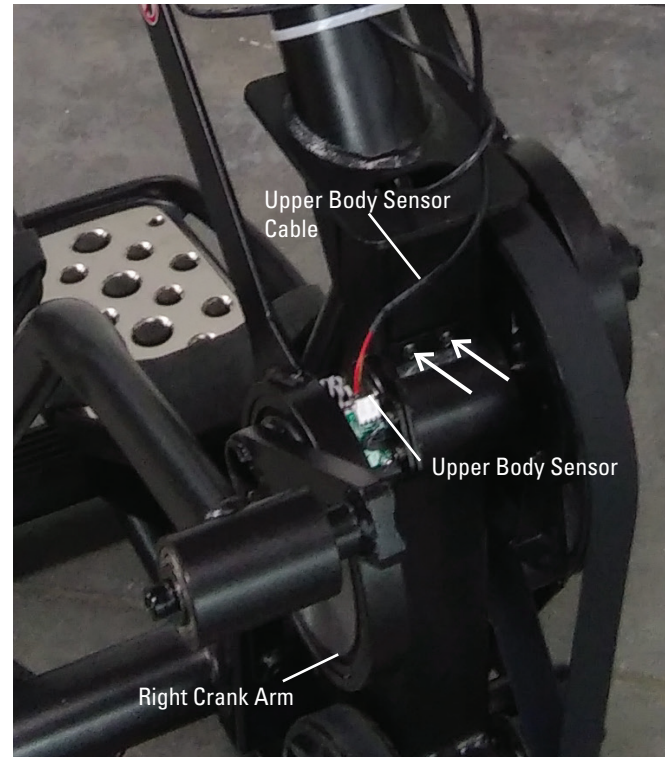

Note: Shrouds are removed for clarity.

20. Using a 9/16" or 14mm socket and wrench, remove the indicated nut from the Crank Assembly.



21. Adjust the Crank Puller until the end of the Bolt is inside the Nut (as shown).



22. Carefully thread the Crank Puller into the Crank Arm. Be sure the Crank Puller has at least three rounds of threads inserted.

23. Using an adjustable wrench, turn the inner portion (the Bolt) of the Crank Puller clockwise. The Crank Arm Assembly will slide off as it is tightened.

Note: Be aware that the Crank Arm Assembly will be loose and will need to be supported.

24. Remove the Crank Puller from the Crank Arm.



25. Using a 2mm hex wrench, loosen the two screws (indicated by arrows) that secure the Inner Codewheel Assembly.

26. After noting the orientation of the Inner Codewheel Assembly on the axle, remove the old Inner Codewheel Assembly. Replace with the new Inner Codewheel Assembly so it is in the same orientation.

27. Using the 2mm hex wrench, tighten the two screws that secure the Inner Codewheel Assembly.

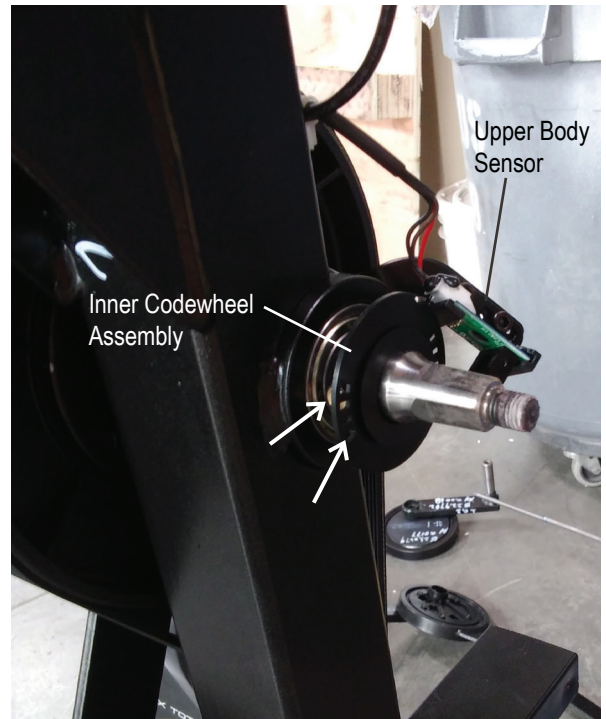

28. Slide the Right Crank Arm Assembly onto the machine.

Note: Be sure not to damage or break the Outer Codewheel on the Right Crank Arm or the one still remaining on the machine.

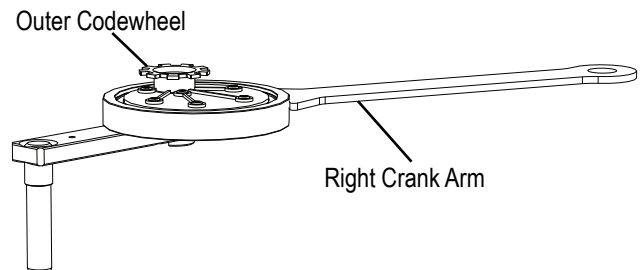

29. Re-attach the Upper Body Sensor so that it is centered on the Outer and Inner Codewheels.

30. With the Upper Body Sensor centered on the Codewheels, confirm that the Upper Body Sensor does not rub anything by using the machine briefly. Adjust the Upper Body Sensor as necessary.

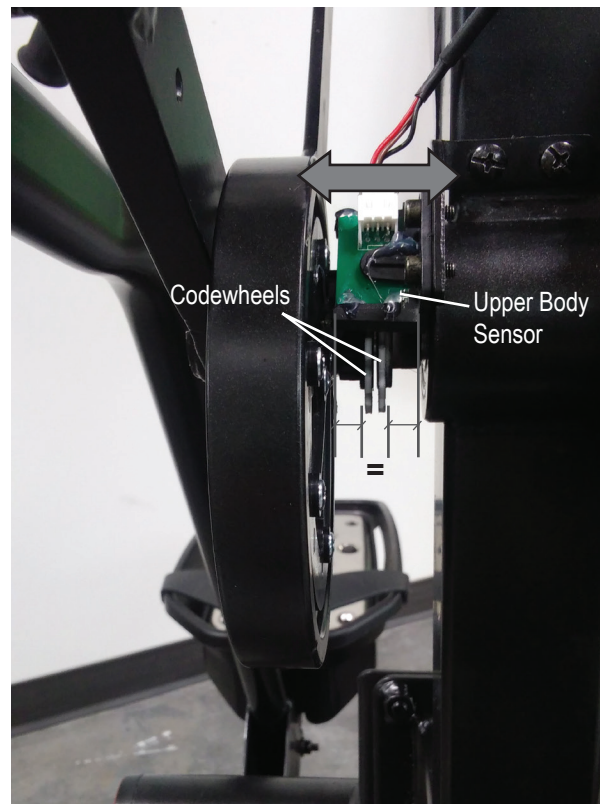

Note: The image shows a properly installed Upper Body Sensor. Shrouds are removed for clarity.

31. Installation is the reverse procedure excluding steps with the Crank Puller. The Crank Puller is not required for re-assembly.

Note: When replacing the Right Crank Arm, be sure the Right and Left Crank Arms are oriented inline and opposite each other. The Crank Nut should be tightened to a torque value of 29-32.5 ft lbs (or 350-390 in lbs).

32. Final Inspection

Inspect your machine to ensure that all hardware is tight and components are properly assembled.



Do not use until the machine has been fully assembled and inspected for correct performance in accordance with the Owner's Manual.

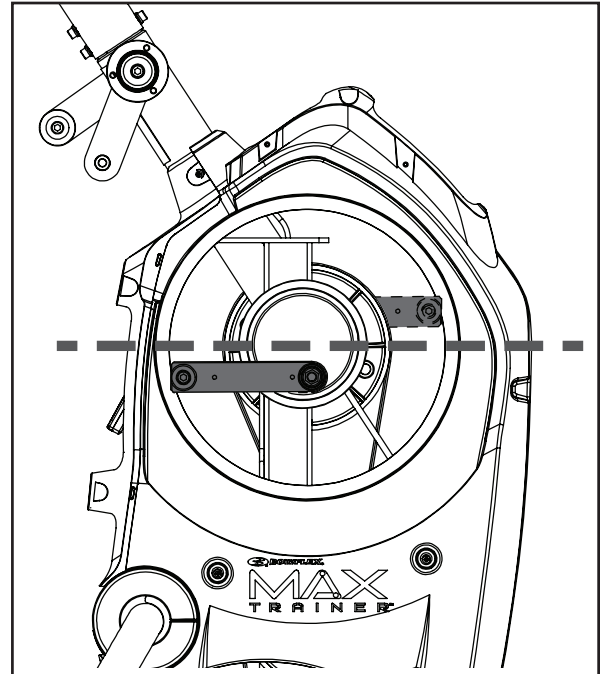

NOTICE: This document provides instructions for the replacement of the Main Wiring Harness on the Bowflex™ Max Total™ machine / Max Total™ 16/40 / Max Trainer™ M9.

If you need assistance, please contact Customer Service (if purchased in US/Canada) or your local distributor (if purchased outside US/Canada). To find your local distributor, go to: www.nautilusinternational.com



This icon means a potentially hazardous situation which, if not avoided, could result in death or serious injury. Read and understand all Warnings on this machine.

Nautilus, Inc., www.NautilusInc.com, 5415 Centerpoint Parkway, Groveport, OH 43125 U.S.A. - Customer Service: North America (800) 605-3369, csnls@nautilus.com | outside U.S. www.nautilusinternational.com | Printed in China | © 2020 Nautilus, Inc. | Bowflex, the B logo, Max Total, and Max Trainer are trademarks owned or licensed by Nautilus, Inc., registered or otherwise protected by common law in the United States and other nations. | **ORIGINAL DOCUMENT - ENGLISH VERSION ONLY**

Important Safety Instructions - Before servicing or using this equipment, obey the following warnings:



This icon means a potentially hazardous situation which, if not avoided, could result in death or serious injury. Read and understand all Warnings on this machine.

- Read and understand the Part Replacement Procedure before working on the machine. Failure to obey the instructions and safety warnings could cause injury to the service technician or bystanders.
- Keep bystanders, children and pets away from the product being serviced at all times.
- Make sure that the repair is done in an appropriate work space away from foot traffic and exposure to bystanders.
- Disconnect all power and allow to sit for 5 minutes before you service this machine.
- Some components of the equipment can be heavy or awkward. Enlist the service of a second person when you do maintenance steps involving these components. Do not try to do heavy or awkward steps on your own.
- If replacement parts are necessary, use only genuine Nautilus replacement parts and hardware. Failure to use genuine replacement parts can cause a risk to users, keep the machine from operating correctly and will void the warranty.
- Be sure that all warning stickers and instructional placards applied to the product stay present and in good condition when doing maintenance or replacing components. If at any time the Warning labels become loose, unreadable or dislodged, replace the labels. If purchased in US/Canada, contact Customer Service for replacement labels. If purchased outside US/Canada, contact your local distributor for them.
- Do not try to change the design or functionality of the machine being serviced as this can adversely effect user safety and will void the warranty.
- Do not use the machine until all shrouds, instructions, warning labels and correct functionality have been verified and tested for correct performance.

• SAVE THESE INSTRUCTIONS.

Tools Required (not included)

#2 Phillips screwdriver

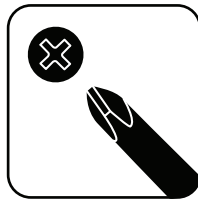

5mm hex wrench



(2) Replacement Zip-Ties

Something to cut Zip-Ties

Piece of wire or string (around 6" in length)



Note: Your machine may not match the images provided exactly.

1. Unplug the AC Adapter from the wall outlet and machine.

2. Remove the Right Stabilizer Shroud from the machine.



3. Using a #2 Phillips screwdriver, remove the indicated (by ovals) screws and only loosen the lowest indicated screw (arrow) from the Right Fan Cover.

Note: Loosen the lowest screw by at least 3 full rotations.

To assist with re-assembly, note that the upper screw is a machine screw and not a self-tapping screw.

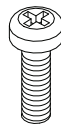

4. The Right Fan Cover has a tab that needs to be pushed upward to clear the loosened screw. While pushing up on the tab, remove the Right Fan Cover from the assembly.

Note: The Power Cable is attached to the inside of the Right Fan Cover. Be sure not to crimp the cable by placing the Right Fan Cover close to the front of the machine.

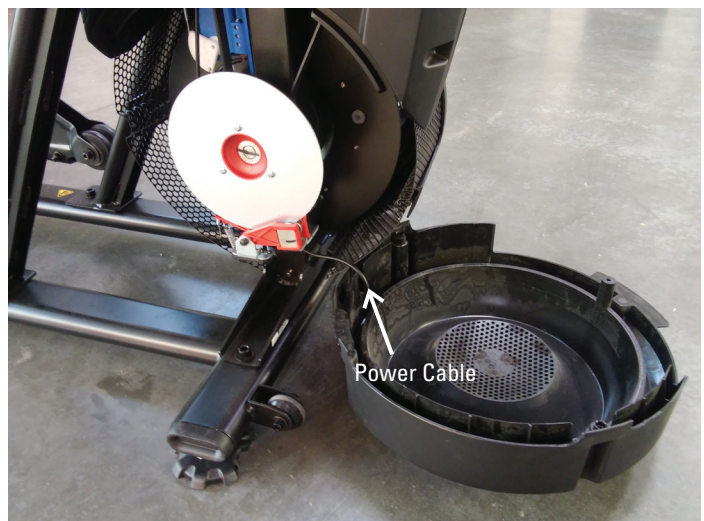
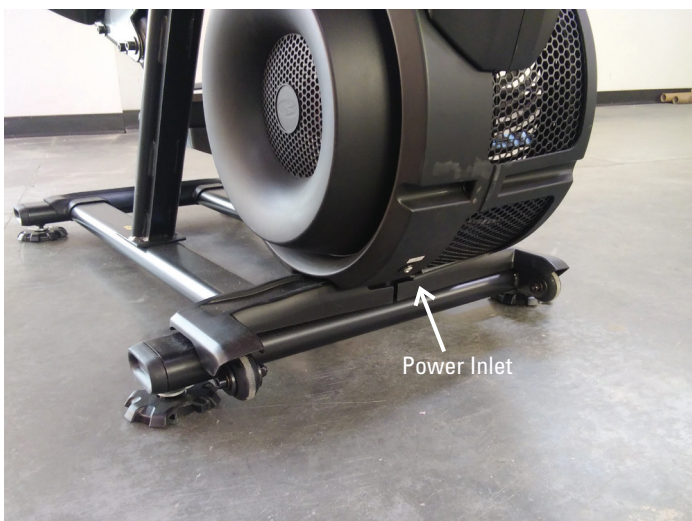

Note: Shrouds are removed for clarity.

5. Note how the I/O Cable routes through the machine.



6. Cut the two lower Zip-Ties without damaging the Cables.

7. Disconnect all the Cables that connect to the lower part of the old I/O Cable.

8. Connect all the Cables to the new I/O Cable.

9. Attach the unattached end of the new I/O Cable to the old I/O Cable using a piece of wire or string.

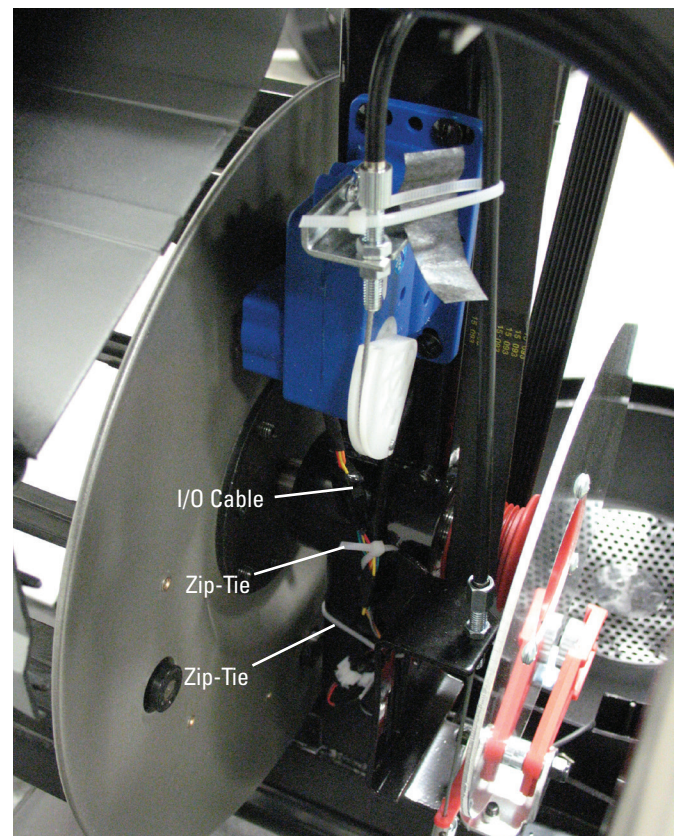

10. Using a 5mm hex wrench, remove the screws (indicated by ovals) from the Static Handlebar Assembly.



11. Carefully lift the Console and Static Handlebar Assembly and expose the Cable Connections.

Note: Do not crimp any of the Cables. This step may require two people.

12. Carefully disconnect the Cables while not allowing them to fall into the Frame Assembly.

Note: Do not crimp any of the Cables.

13. Carefully place the Console and Static Handlebar Assembly out of the work area without crimping any of the Cables.

14. Gently pull the old I/O Cable out of the frame, routing the new I/O Cable into place.

15. Remove the piece of wire or string, and discard the old I/O Cable.

16. Secure the lower Cables with a replacement Upper Zip-Tie.

17. Re-assemble the machine in the reverse order of when the parts were removed.

Note: When attaching the Console and Static Handlebar Assembly, do not fully tighten the hardware until all hardware has been hand tightened. Do not crimp any of the Cables.

18. Final Inspection

Inspect your machine to ensure that all hardware is tight and components are properly assembled.

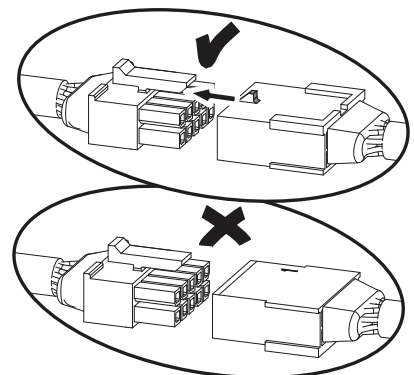
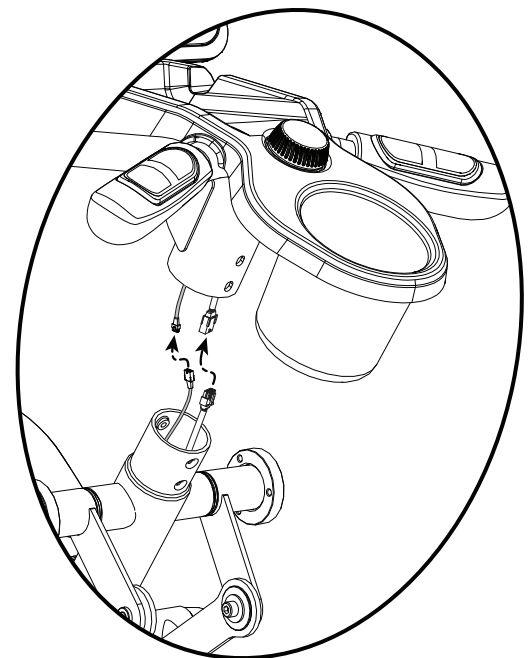

Do not use until the machine has been fully assembled and inspected for correct performance in accordance with the Owner's Manual.